

Introduction to Drinking Water Quality Testing

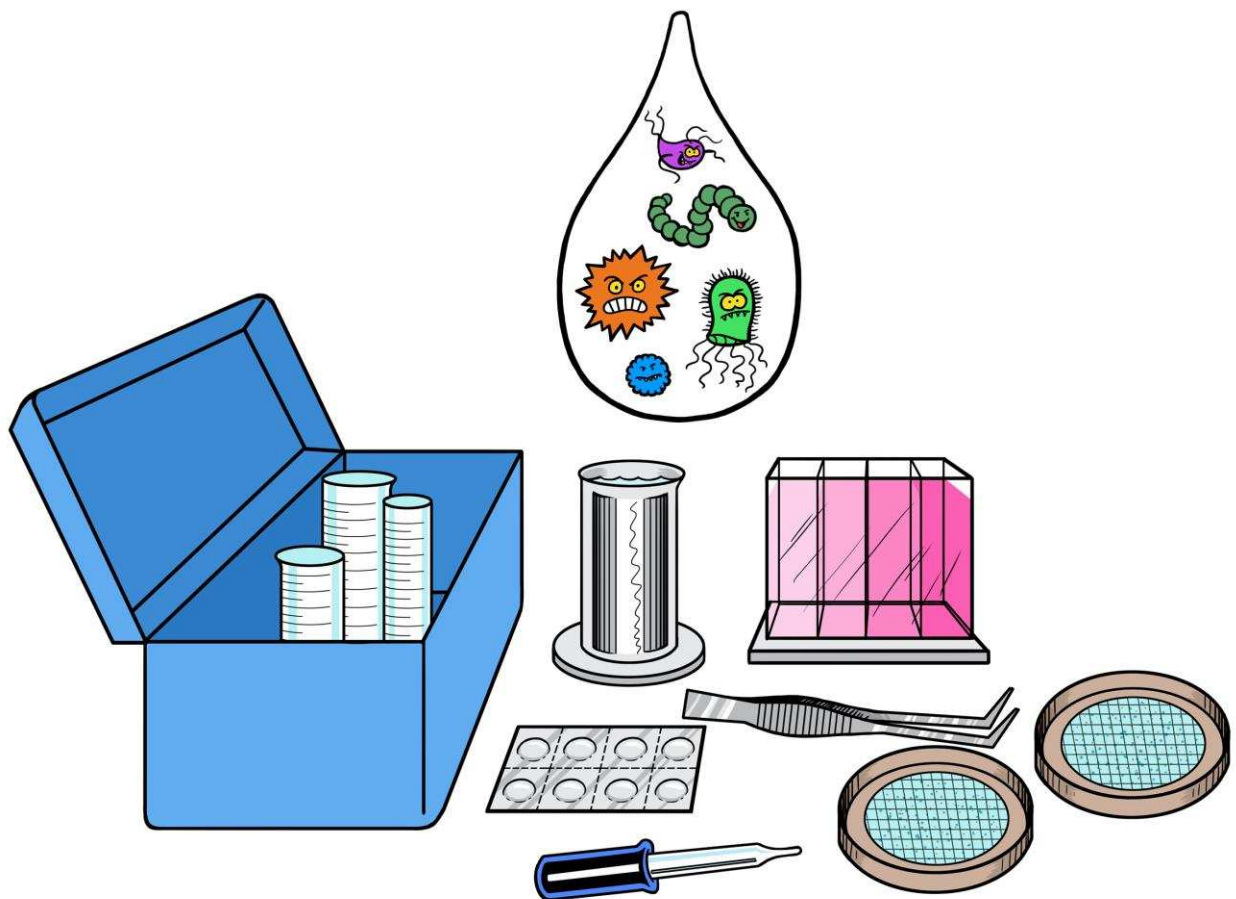



424 Aviation Road NE
Calgary, Alberta, T2E 8H6, Canada
Phone: + 1 (403) 243-3285, Fax: + 1 (403) 243-6199
E-mail: resources@cawst.org, Website: www.cawst.org

CAWST, the Centre for Affordable Water and Sanitation Technology, is a nonprofit organization that provides training and consulting to organizations working directly with populations in developing countries who lack access to clean water and basic sanitation.

One of CAWST's core strategies is to make knowledge about water common knowledge. This is achieved, in part, by developing and freely distributing education materials with the intent of increasing the availability of information to those who need it most.

This document is open content and licensed under the Creative Commons Attribution Works 3.0 Unported License. To view a copy of this license, visit <http://creativecommons.org/licenses/by/3.0> or send a letter to Creative Commons, 171 Second Street, Suite 300, San Francisco, California 94105, USA.



You are free to:

- Share – to copy, distribute and transmit this document
- Remix – to adapt this document



Under the following conditions:

- Attribution. You must give credit to CAWST as the original source of the document. Please include our website: www.cawst.org

CAWST will produce updated versions of this document periodically. For this reason, we do not recommend hosting this document to download from your website.



Stay up-to-date and get support:

- Latest updates to this document
- Other workshop & training related resources
- Support on using this document in your work

CAWST provides mentorship and coaching on the use of its education and training resources.

www.cawst.org

CAWST and its directors, employees, contractors and volunteers do not assume any responsibility for and make no warranty with respect to the results that may be obtained from the use of the information provided.

Table of Contents

Section 1: Overview of Drinking Water Quality Testing

Section 2: Planning for Drinking Water Quality Testing

Section 3: Sanitary Inspections

Section 4: Water Sampling and Quality Control

Section 5: Testing for Physical Parameters

Section 6: Testing for Chemical Parameters

Section 7: Testing for Microbiological Parameters

Section 8: Interpreting Test Results

Appendix 1: Sanitary Inspection Forms

Appendix 2: Product Sheets

Appendix 3: Chemical Fact Sheets

Appendix 4: WHO Guidelines for Chemicals and Health Effects

Appendix 5: Culture Media

Appendix 6: Data Recording Forms

Appendix 7: Water Quality Testing Report

Appendix 8: International Travel with Test Equipment and Materials

Appendix 9: Country Fact Sheets



Acronyms

AAS	atomic absorption spectrometer
BSF	biosand filter
CAWST	Centre for Affordable Water and Sanitation Technology
CFU	colony forming units
DWQT	drinking water quality testing
EC	electrical conductivity
ENPHO	Environment and Public Health Organization
FC	fecal coliform
FRC	free residual chlorine
FTU	Formazin turbidity units
H ₂ S	hydrogen sulphide
HWT	household water treatment
HWTS	household water treatment and safe storage
ICP	inductively coupled plasma
L	litre
m	metre
MCL	maximum contaminant level
MF	membrane filtration
mg	milligram
mL	millilitre
MLSB	membrane lauryl sulphate broth
mm	millimetre
MPN	most probable number
ND	no date, not detected
NGO	nongovernmental organization
NTU	nephelometric turbidity units
P-A	presence-absence
PPB	parts per billion
PPM	parts per million
SMCL	secondary maximum contaminant level
SODIS	solar disinfection

SOP	standard operation procedure
TC	total coliforms
TCU	true colour units
TDI	tolerable daily intake
TDS	total dissolved solids
TNTC	too numerous to count
TTC	thermotolerant coliform
μg	microgram
μm	micrometer
UN	United Nations
UNDP	United Nations Development Programs
UNICEF	United Nations Children's Education Fund
US EPA	United States Environmental Protection Agency
WHO	World Health Organization

Measurement Conversions

Length or Distance

1 foot = 0.30 metres

1 m = 3.28 feet

1 inch = 25.4 mm

1 inch = 2.54 cm

1 cm = 0.39 inches

1 cm = 10 mm

1 mm = 0.1 cm

1 mm = 1,000 μm

1 μm = 0.001 mm

Volume

1 gallon = 3.78 L

1 L = 0.26 gallons

1 L = 33.8 fluid oz (US)

1 L = 1,000 mL

1 mL = 0.001 L

Weight

1 kg = 1,000 g

1 g = 0.001 kg

1 g = 1,000 mg

1 mg = 0.001 g

1 mg = 1,000 μg

1 μg = 0.001 mg

Concentration

1 ppm = 1 mg/L = 1/1 million = 0.000001

1 ppb = 1 $\mu\text{g}/\text{L}$ = 1/1 billion = 0.000000001

To convert ppb to ppm divide by 1,000

To convert ppm to ppb multiply by 1,000

To convert $\mu\text{g}/\text{L}$ to mg/L divide by 1,000

To convert mg/L to $\mu\text{g}/\text{L}$ multiply by 1,000



Glossary

Accuracy	How close a measured value is to the actual (true) value.
Adsorption	When a contaminant attaches or sticks to the surface of a solid, such as a grain of sand.
Agar	A semi-solid gel with nutrients used to grow bacteria.
Aseptic technique	Preventing contact with microorganisms.
Bacteria	Single-celled microorganisms, typically a few micrometres (μm) in length. They can live in water, soil, in animals and on plants. Bacteria are usually too small to see with the human eye. Some, but not all, bacteria can make you sick.
Blue-baby syndrome	An illness most common in young infants that can be caused by drinking high amounts of nitrate, which results in the blood losing its ability to effectively carry oxygen.
Boiling	Disinfection of water by heating it until it bubbles. To kill all the pathogens in the water, you must boil water at a full or “rolling” boil (lots of bubbles covering the whole surface of the water) for at least 1 full minute.
Broth	A liquid with nutrients used to grow bacteria.
Carcinogenic	A chemical that can cause cancer.
Chronic	Continuing or occurring again and again for a long time. Opposite of acute.
Coliform	A group of generally harmless bacteria which may come from feces or the natural environment.
Colony (bacterial)	A group of bacteria growing on the surface of culture media. A colony usually starts growing from a single bacteria and appears as a circular dot on the culture media.
Community water supply	The management and administration of the water supply usually handled by the local community. Community water supplies may include simple piped water systems, boreholes with mechanized or hand pumps, dug wells and protected springs.
Concentration	The ratio of the quantity of any substance present in a sample of given volume or a given weight compared to the volume or weight of the sample (e.g., mg/L, $\mu\text{g/L}$, ppm, ppb).
Consumable	Items that are used once or for a limited time and then disposed. Must be purchased on a regular basis for water quality testing (e.g.,

reagents, filter paper, absorbent pads).

Contamination	Pollution of water due to human or natural causes.
Culture media	Combination of nutrients and reagents used to grow bacteria. Broths and agars are two examples of culture media.
Deionized water	Also known as demineralized water. Water that has had its minerals removed, such as sodium, calcium, iron, copper, chloride and sulfate. Deionization is a chemical process that removes the minerals from water. However, deionization does not significantly remove pathogens (e.g., viruses, bacteria).
Disinfection	A process that removes, deactivates, or kills pathogens in water. It is the last step of the household water treatment process, after sedimentation and filtration. Disinfection is less lethal than sterilization because it destroys most pathogens, but not necessarily all of them (e.g., bacterial spores).
Distilled water	Water that has many of its chemical, physical and microbiological impurities (e.g., minerals, turbidity, pathogens) removed through distillation. Distillation involves boiling the water and then condensing the steam into a clean container, thus leaving all of the impurities behind.
Drinking water quality	The chemical, physical, and microbiological parameters of drinking water.
Effluent	A discharge of liquid waste or sewage.
Equipment	The permanent hardware that is usually only purchased one time for water quality testing (e.g., incubator, scale, digital meters).
Fecal bacteria	Bacteria found in the feces of humans or warm-blooded animals. Their presence indicates fecal contamination of water and the possible presence of pathogens.
Filter paper	A porous paper used in membrane filtration through which the water sample is filtered and which retains the bacteria. Pore sizes for fecal bacteria are between 0.45 and 0.7 μm .
Flow rate	The speed at which water flows through a filter. The flow rate can be measured as the amount of time it takes to fill a container of water - often a 1 litre container. For the biosand filter, the flow rate should be measured when the reservoir is completely full of water.
Fresh water	Water that contains less than 1,000 mg/L of dissolved solids such as salt.
Guideline	A recommended limit that <u>should</u> not be exceeded.

Helminth	Worm or fluke. They can live in water, soil, in animals and on plants. Helminths can be very small (hard to see with the human eye), or large (up to meters in length!). They are parasites – they can live inside you and take nourishment (food) from you, making you sick.
Implementation	The process of carrying out a plan. The implementation phase of a project happens after the project plan has been created.
Incidence	Incidence is the rate of new (or newly diagnosed) cases of the disease. It is generally reported as the number of new cases occurring within a period of time (e.g., per month, per year). It is more meaningful when the incidence rate is reported as a fraction of the population at risk of developing the disease (e.g., per 100,000 or per million population). Also see definition of “prevalence”.
Indicator organism	There are many different kinds of microorganisms that cause diseases that it would be too expensive and time consuming to test for each one. We test for fecal contamination by using indicator organisms. These are microorganisms whose presence in water signals the presence of feces, and potentially, pathogens. One such indicator organism is <i>Escherichia coli</i> , a bacteria that is normally found in the feces of humans and other warm-blooded animals.
Material	Items that are only used once or for a limited time and then disposed. Must be purchased on a regular basis for water quality testing. Also called a consumable.
Membrane filtration	Water quality testing method used to measure microbiological contamination by counting the number of indicator bacteria colony forming units (CFU).
Microbiological contamination	Pathogens in water that can make you sick. Microbiological contamination can come from human and animal feces, garbage, or from the environment.
Microorganism	A tiny living thing, including protozoa, bacteria and viruses. Most are too small to see with the human eye. Microorganisms, also called “microbes”, can live in water, soil, in animals or on plants. Some, but not all, microorganisms can make you sick.
Mutagenic	A chemical that can change the genes of a living thing that causes physical characteristics that are different from what is normal.
Nephelometric Turbidity Unit (NTU)	Unit of measure for the turbidity of water. A measure of the cloudiness of water as measured by a nephelometer. Turbidity is based on the amount of light that reflects off the particles in water.
Nutrient	Any substance used by microorganisms to live and grow. The term is generally applied to nitrogen and phosphorus in contaminated water, but can be used to describe other chemicals.

Pathogen	Any living organism that causes disease. Pathogens commonly found in drinking water include bacteria, viruses, protozoa and helminths.
Precision	How close the measured values are to each other.
Prevalence	Prevalence is the actual number of cases alive, with the disease either during a period of time (period prevalence) or at a particular date in time (point prevalence). Period prevalence provides the better measure of the disease load since it includes all new cases and all deaths between two dates, whereas point prevalence only counts those alive on a particular date. It is more meaningful when the incidence rate is reported as a fraction of the population at risk of developing the disease (e.g., per 100,000 or per million population). Also see definition of “incidence”.
Protozoa	Multi-celled microorganisms, often with a hard shell. They can live in water, soil, in animals and on plants. They are very small, but some protozoa can be seen with the human eye. Some, but not all, protozoa can make you sick.
Quality assurance	Aims to prevent errors with a focus on the process. It is a proactive quality process.
Quality control	Aims to identify errors in the finished product. It is a reactive process.
Random sample	A sample that is chosen without a particular pattern.
Reagent	A chemical or biological substance that is needed to do a particular water quality test. A reagent can be used to detect or measure a contaminant or prepare a product like culture media.
Risk	The likelihood of a hazard causing harm to exposed populations in a specific time frame and the magnitude and/or consequences of that harm.
Sanitary inspection	On-site visual inspection of a water supply to identify actual and potential sources of contamination. The physical structure and operation of the systems, as well as external factors (such as latrine location) are evaluated. This information can be used to select appropriate actions to protect or improve the water supply
Shelf life	The length of time that something may be stored and still be good to use before the expiration date.
SODIS	Solar disinfection of water by putting clear water in clear plastic bottles and leaving them in the sun. The UV rays from the sun kill the pathogens in the water.
Standard	A mandatory limit that <u>must</u> not be exceeded; standards often reflect

a legal duty or obligation.

Sterilize

To kill all microorganisms - whether pathogenic or not - and their spores present on a surface or object. Sterilization is more lethal than disinfection.

Suspended solids

Small solid particles such as dirt which float in water and cause turbidity. They can be removed by sedimentation or filtration.

Toxic

A chemical that can cause serious injury or death because it is poisonous to living things.

Treatment effectiveness

Also called removal effectiveness. How well a household water treatment technology (HWT) treats water. It can be expressed as the percentage of specific contaminants that is removed from the water, such as "98.5% of bacteria".

Turbidity

The "cloudiness" or "dirtiness" of water. Turbidity is caused by suspended solids, such as sand, silt and clay, floating in water. Light reflects off these particles, which makes the water look cloudy or dirty. Turbidity is measured in nephelometric turbidity units (NTU).

Virus

Single-celled microorganisms. They can live in water, soil, in animals and on plants. Viruses are too small to see with the human eye. Some, but not all, viruses can make you sick.

Introduction to Drinking Water Quality Testing

Section 1: Overview of Drinking Water Quality Testing

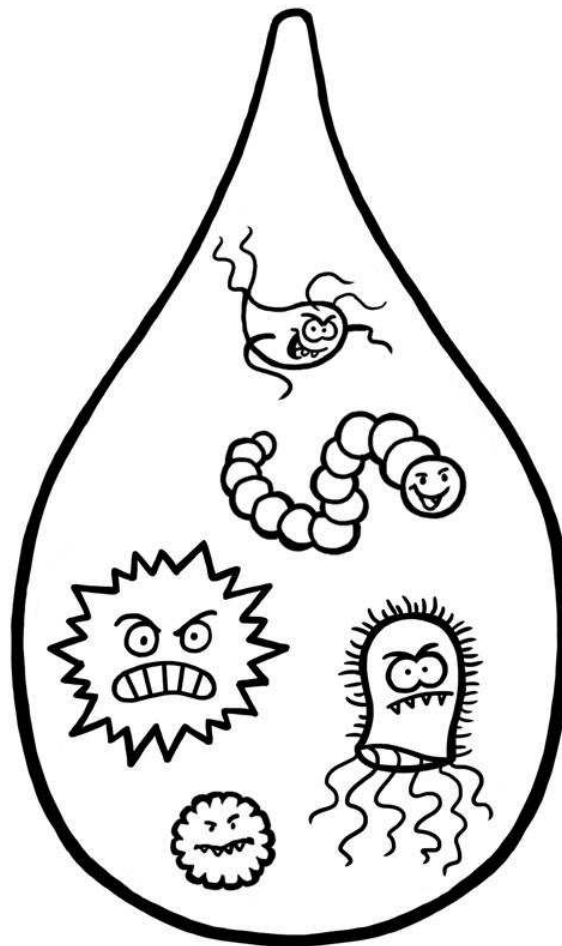

Table of Contents

Section 1: Overview of Drinking Water Quality Testing	i
1.1 Introduction	1
1.2 Drinking Water Quality	3
1.3 Multi-barrier Approach to Safe Drinking Water	4
1.4 Drinking Water Quality Guidelines and Standards	5
1.5 Drinking Water Quality Testing Options	5
1.5.1 Observation	5
1.5.2 Using Portable Test Kits	6
1.5.3 Mobile Laboratory Testing	8
1.5.4 Using a Commercial Laboratory	8
1.5.5 Setting Up a Project Laboratory	8
1.6 CAWST Lessons Learned	10
1.7 Summary of Key Information	10
1.8 References	11

1.1 Introduction

Having safe drinking water is a human need and right for every man, woman and child. People need clean water to maintain their health and dignity. Having better water is essential in breaking the cycle of poverty since it improves people's health, strength to work, and ability to go to school.

However, declining water quality threatens the gains made over the past twenty years to improve access to drinking water. From 1990 to 2011, global efforts have helped 2.1 billion people gain access to improved drinking water, but not all of these new sources are necessarily safe (WHO/UNICEF, 2013).

The quality of our global freshwater supplies is under increased threat of contamination. While water contains natural contaminants, it is becoming more and more polluted by human activities, such as open defecation, inadequate wastewater management, dumping of garbage, poor agricultural practices, and chemical spills at industrial sites.

Chemical contamination of drinking water – both naturally occurring and from pollution – is a very serious problem. Arsenic and fluoride alone threaten the health of hundreds of millions of people globally.

But even more serious is microbiological contamination, especially from human feces. Fecal contamination of drinking water is a major contributor to diarrheal disease. Globally, an estimated 2,000 children under the age of five die every day from diarrheal diseases. Almost 90% of child deaths from diarrheal diseases are directly linked to contaminated water, lack of sanitation, or inadequate hygiene (UNICEF Canada, 2013). For every child that dies, countless others, including older children and adults, suffer from poor health and missed opportunities for work and education.

Water quality testing is a tool that can be used to help identify safe drinking water – whether at the source, within a piped distribution system, or within the home. Water testing plays an important role in monitoring the correct operation of water supplies, verifying the safety of drinking water, investigating disease outbreaks, and validating processes and preventative measures (Bain et al., 2012).

However, you cannot rely only on water quality testing to protect public health since it is not physically or economically feasible to test all drinking water. You must also use other tools and resources, like sanitary surveys and monitoring, to help ensure water quality.

This Manual provides introductory information and resources on drinking water quality testing to help you determine if water quality testing is an appropriate tool for your water projects. While much of the information can be used globally, this Manual is intended for water, sanitation and hygiene (WASH) practitioners in developing countries where there is limited access to resources.

The following topics are addressed in this Manual:

- Characteristics of safe drinking water
- Planning for water quality testing
- Sanitary surveys as a means to observe water quality
- Testing options, including portable field kits and laboratories
- Physical, chemical and microbiological parameters and test procedures
- Interpreting water quality test results

As well, CAWST shares its practical experience and lessons learned from working with over 1,000 clients on water, hygiene and sanitation projects in Africa, Asia, the Middle East, Latin America and the Caribbean. We would also like to hear from you and include your water quality testing experience in our next Manual update. Please contact us at: resources@kawst.org to share your experience, comments and suggestions.

What Does Improved and Safe Drinking Water Mean?

- **Improved drinking water source** is a drinking water source or delivery point that, by how it is designed and constructed, is likely to protect the water from outside contamination, in particular from feces. Improved drinking water sources include piped water, public tap/standpipe, tubewell/borehole, protected dug well, protected spring, collected rainwater and bottled water (only when another improved source is used for cooking and personal hygiene).
- **Safe drinking water** does not have any significant risk to a person's health over their lifetime. Safe drinking water has microbiological, chemical and physical characteristics that meet World Health Organization (WHO) guidelines or national standards for drinking water quality.

(WHO/UNICEF, 2013)

1.2 Drinking Water Quality

We find our drinking water from different places depending on where we live in the world. Three sources that are used to collect drinking water are:

- Groundwater – Water that fills the spaces between rocks and soil making an aquifer. Groundwater depth and quality varies from place to place. About half of the world's drinking water comes from the ground.
- Surface water – Water that is taken directly from a stream, river, lake, pond, spring or similar source. Surface water quality is generally unsafe to drink without treatment.
- Rainwater – Water that is collected and stored using a roof top, ground surface or rock catchment. The quality of rainwater collected from a roof surface is usually better than a ground surface or rock catchment.

As water moves through the water cycle, it naturally picks up many things along its path. Water quality will naturally change from place to place, with the seasons, and with the kinds of rocks and soil which it moves through.

Water can also be polluted by human activities, such as open defecation, inadequate wastewater management, dumping of garbage, poor agricultural practices (e.g., use of fertilizers or pesticides near water sources), and chemical spills at industrial sites. In developing countries, 75% of all industrial waste and up to 95% of sewage is discharged into surface waters without any treatment (Carty, 1991).

Even though water may be clear, it does not necessarily mean that it is safe for us to drink. It is important to judge the safety of water by taking the following three types of parameters into consideration:

- Microbiological – bacteria, viruses, protozoa and helminths (worms)
- Chemical – minerals, metals, chemicals and pH
- Physical – temperature, colour, smell, taste and turbidity

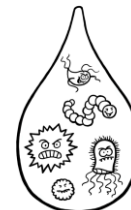

Safe drinking water should have the following microbiological, chemical and physical parameters:

- Free of pathogens (A pathogen is any living organism that causes disease. Pathogens commonly found in drinking water include bacteria, viruses, protozoa and helminths)
- Low in concentrations of toxic chemicals
- Clear
- Tasteless, odourless and colourless (for aesthetic purposes)

Microbiological quality is usually the main concern since infectious diseases caused by pathogenic bacteria, viruses, protozoa and helminths are the most common and widespread health risk associated with drinking water. Only a few chemicals have caused widespread health effects from people drinking water with excessive quantities of those chemicals. These include fluoride, arsenic and nitrate (WHO, 2011).

1.3 Multi-barrier Approach to Safe Drinking Water

The best way to reduce the risk of drinking unsafe water is to use the multi-barrier approach. The five steps of the multi-barrier approach to safe drinking water are:

1. Protect your source water
2. Sediment your water
3. Filter your water
4. Disinfect your water
5. Store your water safely

Each step in the process, from source protection to water treatment and safe storage, helps reduce health risks. The emphasis should be placed on protecting our water sources first, so that we don't need to rely so much on treatment to make our water safe to drink.

The concept of the multi-barrier approach is also addressed by the WHO as part of the Guidelines for Drinking Water Quality and water safety plans, the principles of which can be applied at both community and household levels. The WHO provides additional information about water safety plans on their website at: www.wsportal.org/ibis/water-safety-portal/eng/home.

Water can be treated at a central location, in large volumes, and then supplied to households through a network of pipes. This is often called centralized or community water treatment. Smaller volumes of water can also be treated at the point of use (POU), such as in institutions (e.g., schools, clinics, religious institutions), and in the home. This is also commonly called household water treatment and safe storage (HWTS) since the family members gather the water, and then treat and store it in their home.

Both conventional (community) and household systems follow the same basic water treatment process, which is the middle three steps of the multi-barrier approach: sedimentation, filtration and disinfection. The main difference between conventional and household systems is the scale of the technologies used.

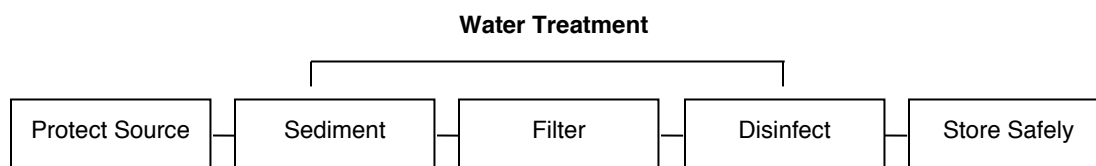

- Sedimenting water removes larger particles and often more than 50% of pathogens
- Filtering water removes smaller particles and often more than 90% of pathogens
- Disinfecting water deactivates or kills any remaining pathogens

1.4 Drinking Water Quality Guidelines and Standards

The WHO is part of the United Nations (UN) and it focuses on international public health. The WHO writes the Guidelines for Drinking Water Quality (2011) to protect public health and help make sure that people are drinking safe water around the world.

The WHO Guidelines explain that safe drinking water will not make people sick at any time throughout their life, including when they are young, old or already sick. Safe drinking water should be good to use for all of our personal needs, including drinking, cooking and washing.

The WHO Guidelines cover microbiological, chemical and physical parameters. However, it is stressed that microbiological quality is the most important since fecal contamination from people and animals is the biggest cause of illness and death around the world.

The implementation of the WHO Guidelines for Drinking Water Quality varies among countries. There is no single approach that is used worldwide. The Guidelines are recommendations to work towards, and they are not mandatory limits. Countries can take the WHO Guidelines into consideration along with the environmental, social, cultural, and economic circumstances particular to the country. This means that many countries have developed their own national standards that are different from the WHO Guidelines, but are still protective of public health.

For example, the Guidelines say that safe drinking water should contain no fecal indicator organisms, such as *Escherichia coli* (*E. coli*). However, in many developing and developed countries, many household and small community drinking water systems, in particular, fail to meet this requirement for water safety, and have some levels of *E. coli*. In such circumstances, many countries (e.g., South Africa) have set more realistic standards for drinking water that allows some level of *E. coli* while they aim for regular improvement in their water quality.

1.5 Drinking Water Quality Testing Options

Historically, conventional laboratories were mainly used to carry out water quality testing. Now there is a wide variety of good kits and products available in the commercial market that allows you to do testing on your own. The following sections present the five different water quality testing methods that are available:

1. Observation
2. Using portable test kits
3. Using a mobile laboratory
4. Sending your samples to a commercial laboratory
5. Setting up your own project laboratory

1.5.1 Observation

Water quality testing tells you about the quality at the time of sampling, but it cannot give you information on either the causes of pollution or possible future trends. Simple observation is a very useful tool to identify potential risks that could affect the current and future quality of drinking water. If contamination is suspected through observing the local environment, then testing is the next step to confirm the water quality.

Poor water quality may be indicated by observing the water source, the immediate household surroundings, containers used to carry water from the source, storage containers, and personal hygiene and sanitation practices. Water quality can also be assessed by making qualitative observations of its physical characteristics such as the turbidity, colour, odour and taste. The general health, well-being or energy levels of the local population can also provide some insight into the quality of the drinking water.

Sanitary inspection is a useful observational technique. It needs no special equipment and it is quick and cheap. Some training may be required, but it does not require highly trained staff. Local conditions can also be taken into consideration during a sanitary inspection.

Section 3 provides more information about how to conduct a sanitary inspection and observation forms are given in Appendix 1: Sanitary Inspection Forms.

Advantages and Limitations of Observation

Advantages	Limitations
<ul style="list-style-type: none"> • Quick and easy • Inexpensive • Does not require specialized equipment • Does not require highly trained staff • Gives information about the causes of pollution and possible future trends 	<ul style="list-style-type: none"> • Does not confirm the water quality or specific type of contamination

1.5.2 Using Portable Test Kits

Water quality testing can be a challenge where resources are limited. The lack of testing available in developing countries highlighted the need for rapid, simple, and inexpensive test methods. This need is especially great for rural and small community and household water supplies that are located far away and who cannot afford commercial laboratory testing. On-site testing using portable kits with simplified test methods have allowed water quality testing to be a possibility in developing countries.

Testing for many physical, chemical and microbiological parameters can be carried out in the field using specifically designed products that are portable and relatively easy to use. In rural and remote communities, it is more convenient to carry out water testing on-site. Another advantage of using portable kits is that tests are carried out on new water samples where the quality has not changed as a result of being stored and transported over long distances.

Manufacturers of portable kits provide a user's manual with simple step-by-step instructions on how to conduct the water quality tests. This makes it easy for people to use and does not require a high level of training. However, some level of training is required to ensure correct use of the equipment and ability to understand and report the results.

Example Portable Test Kits



Potatest® Kit (Credit: Palintest)

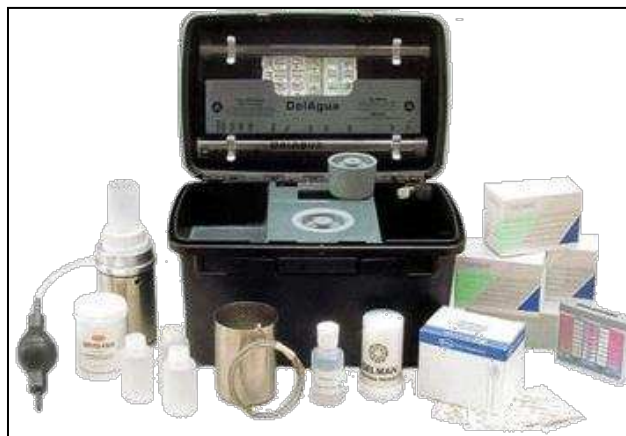

Delagua Kit (Credit: Delagua)

Portable test kits can also be a useful tool to raise awareness about water quality. Community health promoters or field staff can use water quality testing to help bring about positive changes in hygiene and sanitation behaviours. Many tests show visual results, which help people to improve their understanding of their water quality.

Portable water quality test kits should have the following characteristics:

- Easy to use with simple instructions
- Small and easy to transport
- Fast results
- Limited need for distilled or deionized water
- Robust (e.g., limited effects from UV light, shock, humidity, temperature)
- Can test several parameters
- Limited consumables or consumables are easy to obtain
- Reasonable cost of equipment and consumables

Appendix 2: Product Sheets provides more information on the portable tests kits as well as other equipment and materials used by CAWST and other nongovernmental organizations (NGOs).

Advantages and Limitations of Portable Testing Kits

Advantages	Limitations
<ul style="list-style-type: none"> • Easy to use • Portable and self-contained • Rapid results • Does not require high level of training • End users are able to participate in the testing process • Less expensive than laboratory testing 	<ul style="list-style-type: none"> • Reduced precision and accuracy • Reduced level of quality assurance • More difficult to process a large number of samples (over 80 per week) without supplementary equipment

1.5.3 Mobile Laboratory Testing

It is possible to set up a laboratory in a suitable motor vehicle, e.g. truck or van. This is a type of field testing, but a mobile laboratory may provide better facilities than test kits. In practice, it is only feasible where projects are scattered in different locations and they have common water quality testing needs. Government agencies and research centres responsible for monitoring and water quality testing sometimes use mobile laboratories for periodic water quality testing. The vehicle is usually the most costly piece of equipment.

1.5.4 Using a Commercial Laboratory

You can also send your water samples to a commercial laboratory for testing. These laboratories are usually located in larger cities and have dedicated facilities, trained technicians and specialized equipment. Laboratories use international standards for testing and can provide more consistent, accurate and precise results. UNICEF (2010) also recommends that some chemicals, such as lead, cyanide, chromium, mercury and selenium, be tested at a laboratory in order to achieve a reliable result.

Using a commercial laboratory can be useful if you are taking a small number of samples and your project is close to a city where a laboratory is present. However, the relatively high cost of commercial laboratory testing makes it difficult or impossible to use in many developing countries, especially if many tests are needed. The cost of laboratory testing varies depending on the following factors:

- Travel required to deliver water samples to the laboratory
- Type of tests
- Number of tests
- Accuracy and precision level required

Advantages and Limitations of Commercial Laboratories

Advantages	Limitations
<ul style="list-style-type: none"> • Controlled environment • High level of precision and accuracy • High level of quality assurance • More consistent results • More samples can be processed in a shorter time 	<ul style="list-style-type: none"> • Relatively expensive • Usually located in urban areas, may require samples to be transported over long distances • Some laboratories may have limited options of test methods

1.5.5 Setting Up a Project Laboratory

Some larger organizations have set up their own water quality testing laboratories to support their projects. This is usually the case where there are a large number of samples to be taken over a long time frame, and commercial laboratories are not available or are too expensive.

The feasibility to establish a project laboratory depends upon the availability of financial resources, physical facilities, skilled technicians, and testing equipment. Please contact CAWST for further information and consulting support if you wish to establish your own project laboratory.

Advantages and Limitations of a Project Laboratory

Advantages	Limitations
<ul style="list-style-type: none"> • Organization has control over testing to meet project needs • Can be located close to project area • Precision and accuracy can be similar to a commercial laboratory • More samples can be processed in a shorter time • Can conduct testing for other organizations as a source of revenue 	<ul style="list-style-type: none"> • Relatively expensive • Skilled staff and significant training required • Specialized equipment required • Dedicated facilities required

Case Study: Setting Up a Project Laboratory in Zambia

The Seeds of Hope International Partnerships (SHIP) Water Laboratory is a testing and training arm of SHIP in Zambia. The lab functions under the Water Expertise and Training Centre (WET Centre) division of SHIP with the purpose to provide complete water quality testing services to the region.

The SHIP Water Laboratory set up operation in 2009 with funding provided by the Canadian International Development Agency (CIDA) and technical support by the Centre for Affordable Water and Sanitation Technology (CAWST). It took six months and approximately US\$20,000 to establish the new laboratory.

The laboratory was originally started to support water, sanitation and research programs for the WET Centre program and various SHIP departments. It monitored newly drilled boreholes and well recontamination after pump repairs; tested the effectiveness of the biosand filter (BSF) for household water treatment; tested wastewater for agricultural projects; and conducted baseline studies for community needs assessments for hygiene/sanitation and HIV/AIDS projects. The lab began as a portable field testing service and later moved into a dedicated space in the SHIP Resource Centre.

The SHIP Water Laboratory has expanded its services and now offers water quality testing (including testing for microbiological, chemical and physical parameters), delivers training (Introduction to Drinking Water Quality Testing workshop), provides monitoring and evaluation services, and produces presence-absence test kits.

The laboratory capacity has grown to include external clients which provides a source of revenue for the organization. SHIP currently operates two laboratory facilities in Ndola and Lusaka, Zambia servicing numerous stakeholders including the SHIP WET Centre, NGOs, CBOs, government ministries, drilling companies and private individuals. There are two full-time water quality technicians with plans to employ more staff as the demand increases.

(SHIP, 2013)

1.6 CAWST Lessons Learned

Smaller community water supply and HWTS projects that are just getting off the ground do not usually do water quality testing. Many project implementers have shown initial interest in water quality testing; however, they end up finding that it can be a difficult and expensive task. The cost (about US\$2-4 per test) is not affordable for many project implementers who want to conduct water quality testing on a regular basis.

Some larger projects have found portable test kits to be useful in determining the effectiveness of water treatment and for monitoring and evaluating their project implementation. These project implementers may have their own laboratory set up and have received training on water quality testing.

Sometimes project implementers do random testing that is not part of a regular and structured monitoring program. Doing occasional or random tests may provide a false sense of security or inconclusive results as water quality can vary widely and rapidly.

Water quality testing has been used by some projects as an effective tool to raise awareness about the importance of safe water in rural communities. It can be an effective tool for community health promoters or field staff to help bring about positive changes in people's hygiene and sanitation behaviours. Users have a chance to participate in the testing process and they can often visually see the results. However, the results should be interpreted and presented properly to the users to avoid misunderstandings and possible negative behaviour change. For example, showing treated water as being positive for contamination (despite considerable improvement compared to the original source) may discourage the household from using their water.

1.7 Summary of Key Information

- Water quality can be defined by three broad categories: physical, chemical and microbiological.
- The WHO Guidelines for Drinking Water Quality defines safe water as not representing any significant risk to health over the lifetime of consumption.
- Adoption of the WHO Guidelines for Drinking Water Quality varies among countries and regions. There is no single approach that is used worldwide.
- Although there are several contaminants in water that may be harmful to humans, the first priority is to ensure that drinking water is free of microorganisms that cause disease (pathogens).
- There are five options for water quality testing: 1) observation, 2) testing using portable (field) kits, 3) mobile laboratory testing, 4) commercial laboratory testing, and 5) setting up your own project laboratory.

1.8 References

Bain, R; Bartram, J; Elliott, M; Matthews, R; McMahan, L; Tung, R; Chuang, P; and S Gundry. A Summary Catalogue of Microbial Drinking Water Tests for Low and Medium Resource Settings. International Journal of Environmental Research and Public Health, 2012, 9, 1609-1625. Available at: www.mdpi.com/1660-4601/9/5/1609

Carty, W. (1991). Towards an Urban World. Earthwatch (43): 2-4. 1991. Cited in Solutions for a Water-Short World, Population Reports (1998). Population Information Program, Center for Communication Programs, the Johns Hopkins School of Public Health, USA. Volume XXVI, Number 1, September, 1998.

Seeds of Hope International Partnerships (2013). Personal Communication. Ndola, Zambia.

UNICEF (2010). Technical Bulletin No.6, Water Quality Assessment and Monitoring. UNICEF, Supply Division, Copenhagen, Denmark. Available at: www.unicef.org/supply/files/Water_Quality_Assessment_Monitoring.pdf

UNICEF Canada (2013). Children dying daily because of unsafe water supplies and poor sanitation and hygiene, UNICEF says. Available at: www.unicef.ca/en/press-release/children-dying-daily-because-of-unsafe-water-supplies-and-poor-sanitation-and-hygiene-

World Health Organization (2011). Guidelines for Drinking-Water Quality: Second Addendum. Vol. 1, Recommendations, Third Edition. WHO, Geneva, Switzerland. Available at: www.who.int/water_sanitation_health/dwg/secondaddendum20081119.pdf

World Health Organization (2012). Rapid Assessment of Drinking-Water Quality: A Handbook for Implementation. WHO, Geneva, Switzerland. Available at: www.who.int/water_sanitation_health/publications/2012/rapid_assessment/en/index.html

World Health Organization and UNICEF (2013). Progress on Sanitation and Drinking-Water: 2013 Update. WHO, Geneva, Switzerland. Available at: www.wssinfo.org/fileadmin/user_upload/resources/JMPReport2013.pdf

Introduction to Drinking Water Quality Testing

Section 2: Planning for Drinking Water Quality Testing

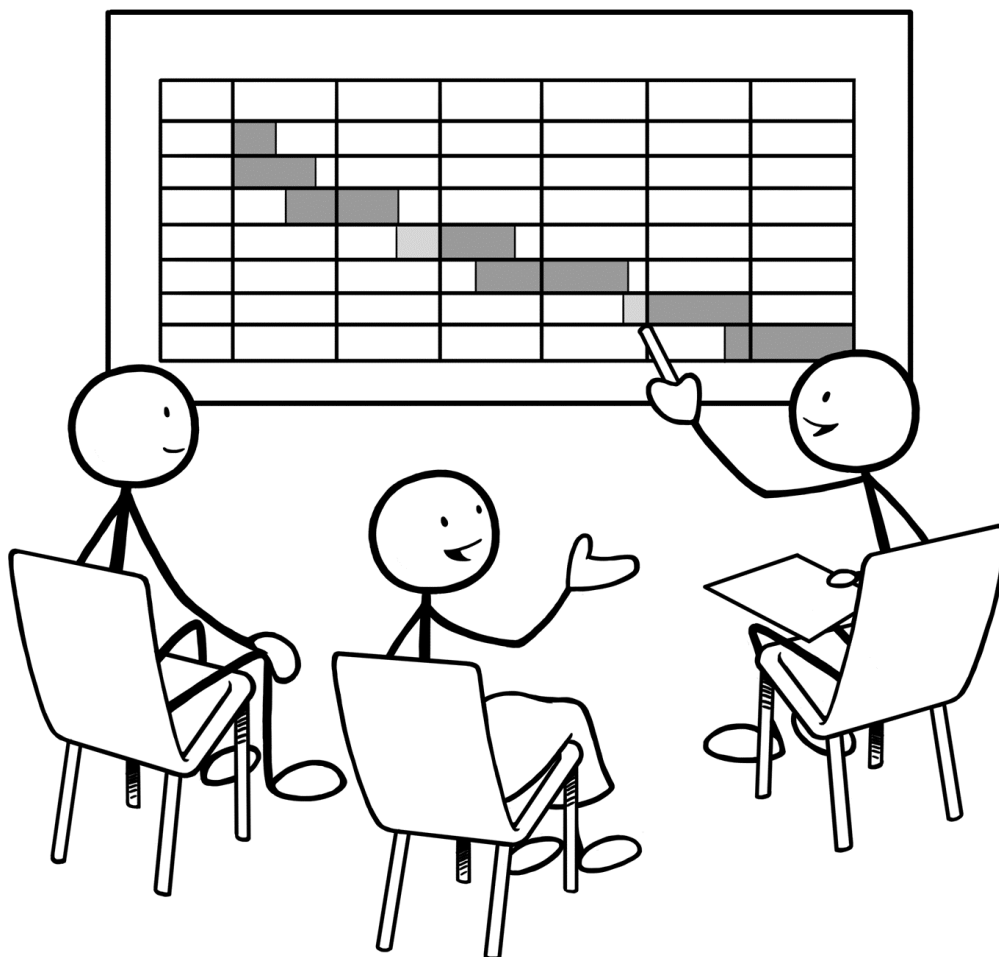

Table of Contents

Section 2: Planning for Drinking Water Quality Testing	i
2.1 Introduction	1
2.2 Review the Need for Testing.....	2
2.3 Develop Objectives	3
2.4 Identify Test Parameters.....	3
2.4.1 Physical Testing.....	5
2.4.2 Chemical Testing	5
2.4.3 Microbiological Testing	5
2.5 Identify Test Methods.....	6
2.6 Design Your Sampling Plan	6
2.6.1 Sample Size for Small Projects (<100 households or locations).....	7
2.6.2 Sample Size for Large Projects (>100 households or locations).....	7
2.6.3 Deciding What Locations to Sample	8
2.7 Determine Key Milestones	9
2.8 Identify Activities	10
2.9 Assign Responsibilities	11
2.10 Develop Time and Cost Estimates.....	12
2.11 Summary of Key Information	13
2.12 References	13



2.1 Introduction

It is important to have a plan before you start doing water quality testing. Planning in advance and thinking through the process will save time, lower costs and prevent surprises during the project. Moreover, it gives a basis for the financial and human resources that will be needed to carry out your testing. It is important to follow the plan once it has been developed, although some changes are often required as you begin to do the testing.

The planning process discussed in this section follows the following well-established practices:

1. Review the need – Why do you need to do water quality testing?
2. Develop your objectives – What are your objectives for testing the water quality?
3. Identify the test parameters – What water quality parameters are you going to test for?
4. Identify the test methods – How are you going to do the testing?
5. Design your sampling plan – How many water samples do you need? Where do you take them from?
6. Determine your key milestones – What achievements need to be reached in order to meet the final goal?
7. Identify your activities – What specific tasks need to be done?
8. Set out responsibilities – Who is going to do what?
9. Develop time and cost estimates – What are the time and costs to complete each activity?

Planning for water quality testing should be done by the people who will be involved in the project. The steps can be done as a facilitated group activity before the testing begins to ensure that the planning is thorough and complete. The planning process may require more time than you initially expected, but time invested in planning is essential for conducting efficient and useful water quality tests.

CAWST also offers more detailed project planning materials that can be downloaded at: http://resources.cawst.org/collection/project-planning-resources-project-implementers_en.

Please contact CAWST at resources@cawst.org if you need additional support while planning for your drinking water quality testing project.

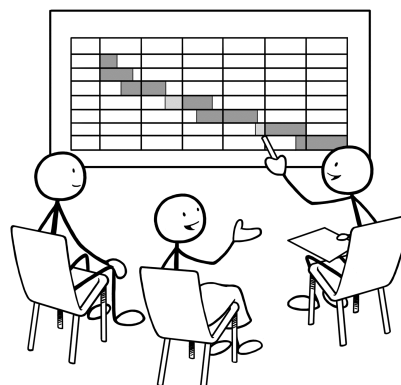

2.2 Review the Need for Testing

Careful judgement about the need for water quality testing is essential. Water quality testing can be an expensive and difficult task if it is done properly. You should review the need for water quality testing within the context of your project and its objectives. When determining if and how much water quality testing to conduct, the following factors should be considered:

- Budget
- Capacity of the staff to conduct testing
- Availability of testing equipment and consumable items
- Logistics involved in sample collection and transportation
- Seasonality and variance of contamination in sources

(Adapted from WHO, 2012)

As discussed in Section 1: Overview of Drinking Water Quality Testing, there are alternative ways to assess water quality, such as conducting user surveys and sanitary inspections. For example, there are different criteria that can be used to measure the performance of community or household water treatment technologies, including:

- Quantity of treated water
- User's satisfaction
- Robustness
- Ease of maintenance and operation
- Affordability
- Availability
- User's perception on taste, smell and colour

However, testing is necessary if you need to assess a treatment technology for its effectiveness in removing contaminants from the drinking water. There are other situations that may also require some water quality testing and where it can be a useful tool, such as:

- End user or community request
- Donor request
- Government verification of a treatment technology
- Monitoring compliance with standards or guidelines
- Research purposes

2.3 Develop Objectives

The objectives of your water quality testing program should meet your project needs and consider the needs of other stakeholders, such as a government regulator or a community water users group. If the stakeholder's needs require resources beyond what you have available, then you should contact them immediately and discuss the objectives. This discussion is important so that the scope of the testing matches the resources available.

The following are some examples of objectives for water quality testing:

- Identify an appropriate drinking water source
- Identify the source of an outbreak of a drinking water related disease
- Investigate seasonal changes in drinking water quality
- Increase user awareness on water quality issues
- Assess the effectiveness of household water treatment and safe storage (HWTS) in reducing turbidity and pathogens
- Assess the concentration of arsenic and fluoride in drinking water
- Provide troubleshooting as part of an ongoing monitoring program
- Monitor compliance with standards or guidelines
- Evaluate the effectiveness of a safe water project

2.4 Identify Test Parameters

Physical, chemical, and microbiological parameters can be measured through water quality testing. The parameters to be tested depend on your project needs, objectives and available resources. However, above all, the parameters for water quality testing should be based on prioritizing those that will have the greatest impact on public health.

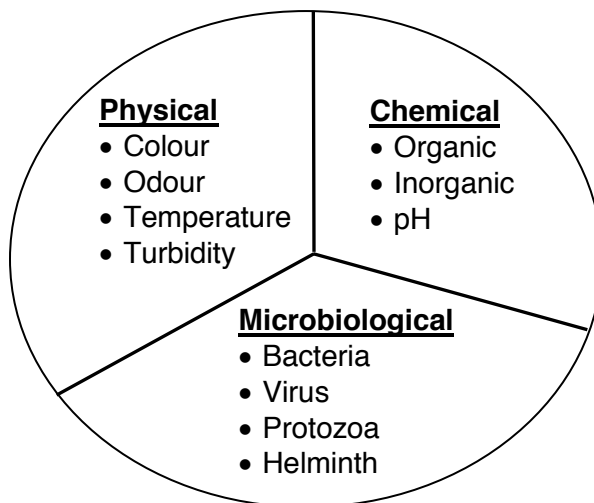

The first step in deciding whether or not a particular parameter should be included in your testing program is to make a judgement on the following questions:

- Is the contaminant known to be present or absent in the waters of the region or country? If known to be present or if no information is available, then the indicator/parameter may be included. If it is known to be absent, then it should be excluded.
- If known to be present, at what concentration does the contaminant exist? Does the concentration exceed national standards or the World Health Organization (WHO) Guidelines?
- What is the extent of the presence of the contaminants? Do they only occur in one region or only during the rainy season?
- Are there any current or planned activities in the area that may cause the contaminant to be present in water or levels to increase? For example, is there an industry located nearby the water source? Do local farmers use fertilizers on their fields?

(Adapted from WHO, 2012)

You can also take the following sources of information into consideration:

- **Health Care Data**

Community health centres or hospitals usually collect some level of information about the numbers of patients and types of illnesses that are treated. This information can indicate how illnesses are spreading throughout the area. For example, if a large number of patients suffering from diarrhea are treated, this would show that poor quality drinking water and hygiene may be the major causes of illness. Local leaders, traditional healers and religious leaders can also be good sources of information about health issues that are occurring within a community.

- **Household and Community Requests**

End users may show interest in their drinking water quality and the effectiveness and reliability of community or household water treatment technology. Sometimes they want to be able to see the pathogens to better understand the process. In this situation, it can be beneficial to do microbiological testing to demonstrate the presence or absence of pathogens in the water.

- **Natural Disasters**

Natural disasters such as flooding, earthquakes and landslides often contaminate water sources. Depending on the type and intensity of the natural disaster, you may need to conduct water quality testing for microbiological contamination.

- **Geographic Location**

Due to natural geological formations, some regions may be prone to arsenic, fluoride or other chemical contamination. Also, you may want to do testing near industrial or agricultural operations where there may be by-products that may cause water contamination.

- **Secondary Information**

Government agencies, research centres or international organizations may carry out a national or regional survey and report on the surface and groundwater quality. This type of information provides a general idea of the local situation, which can help you to determine the water quality parameters required for the area.

2.4.1 Physical Testing

Most physical parameters can be simply observed, like taste, smell and colour. Turbidity is generally the most important physical parameter to measure, since high levels of turbidity are usually associated with high levels of microbiological contamination. As well, high levels of turbidity can reduce the effectiveness of some water treatment technologies.

Physical testing is explained in more detail in Section 5: Testing for Physical Parameters.

2.4.2 Chemical Testing

It is not possible to test water for all of the chemicals that could cause health problems, nor is it necessary. Most chemicals are rarely present, and many result from human contamination of a small area, only affecting a few water sources.

However, three chemicals have the potential to cause serious health problems and occur over widespread areas. These are arsenic and fluoride, which can occur naturally, and nitrate, which is commonly used in fertilizer for agriculture. When planning new water supply projects, these three contaminants should be prioritized for testing (UNICEF, 2008).

A second priority for water quality testing should be for chemical parameters that commonly cause water to be rejected for aesthetic purposes, such as metals (mainly iron and manganese) and total dissolved solids (salinity) (UNICEF, 2008).

When water is disinfected with chlorine, it is also important to monitor the drinking water quality for pH and free residual chlorine (FRC) as indicators of appropriate and effective treatment. As well, it may be important to test for chemicals that are known to be present locally, such as copper or lead from industrial pollution.

Chemical testing is explained in more detail in Section 6: Testing for Chemical Parameters.

2.4.3 Microbiological Testing

By far the most serious public health risk associated with drinking water is microbiological contamination, which makes it the priority for water quality testing. Pathogens in water – bacteria, viruses, protozoa and helminths – can cause a wide range of health problems, but the primary concern is infectious diarrheal disease transmitted by people drinking water contaminated with feces (UNICEF, 2008).

Testing for microbiological contamination is usually the priority in most drinking water projects. *Escherichia coli* (*E. coli*) and/or thermotolerant coliforms (TTC) are the standard for testing for microbiological contamination.

Microbiological testing is explained in more detail in Section 7: Testing for Microbiological Parameters.

2.5 Identify Test Methods

Once you have selected which parameters you will be testing for, you will need to select which test methods you want to use. Section 1: Overview of Drinking Water Quality Testing discussed the different methods available for you to do water quality testing:

- Observation
- Using portable test kits
- Using a mobile laboratory
- Sending your samples to a commercial laboratory
- Setting up your own project laboratory

Sections 5, 6 and 7 provide more details about specific test methods that can be used for physical, chemical and microbiological parameters.

Consider the following points to help you decide which the most appropriate test methods are:

- Objectives of your testing program
- Range of parameter concentrations that need to be determined
 - Detection limits depend on the type of method; both low and high concentrations can usually be tested with more accuracy in a laboratory.
- Accuracy and precision required
 - The greater accuracy and precision required; the greater the test complexity and cost.
- Maximum time period between sampling and analysis
- Technical skills required
- Cost of equipment and consumable items needed for each test

The final decision is often made by your familiarity and comfort with the test method, and/or the availability of the necessary equipment and consumable items in the country.

2.6 Design Your Sampling Plan

Next you need to figure out how many water samples you need and where the samples are going to be taken from. The most important aspect in collecting water samples is to develop a sampling plan, consistently implement the plan and describe why that sampling plan was selected. In addition, documenting what happened when you implemented the plan and how replacement samples or surveys were made if households could not be contacted will assist in understanding the sample selection (WHO, 2012).

First, you will need to determine how many households or water locations to sample. The sample size that you select will depend on:

- Your resources for water quality testing and analyzing data
- The total number of sampling points involved
- The logistics in reaching the sampling points, especially those in rural, remote areas
- How much data is needed to make a good decision
- Your best judgment

Statistical calculations of sample size for more rigorous research are outside the scope of this Manual. However, CAWST can provide you with additional resources for calculating sample size. Please contact us at: resources@cawst.org.

The following guidelines can help you to determine the sample size required for large and small projects.

2.6.1 Sample Size for Small Projects (<100 households or locations)

If resources are available, it would be good to test 100% of the households or locations in a small project. As a minimum, 30% of households or locations should be used as the sample size.

2.6.2 Sample Size for Large Projects (>100 households or locations)

Based on CAWST's experience, it is recommended to use the sample sizes that corresponds to the project size in the following table. It shows that smaller project needs to select relatively a relatively large number of samples. For example, a project with 1,000 households, should test between 43 and 91 of the households to get an adequate representation of the water quality.

Project and Sample Sizes

Project Size	Sample Size
500	41-83
1,000	43-91
2,000	43-95
3,000	44-97
4,000-6,000	44-98
7,000-15,000	44-99
>20,000	44-100

Note: Sample size for $\pm 10\%$ and $\pm 15\%$ precision levels where confidence level is 95% (Adapted from <http://edis.ifas.ufl.edu/>)

Geographical location and socioeconomic status can also be considered during the sample selection. Before determining the sample size, the project can be divided into different geographical areas, such as high land, low land, or coastal areas, to get an accurate representation. Households can also be classified based on socioeconomic status such as high, medium, and low income. Then, 10-20% of the households can be taken as a sample from each geographical area and each socioeconomic group.

2.6.3 Deciding What Locations to Sample

There are different methods to choose who or where you are going to sample. It is best to use a random sample (without a particular pattern) so that there is no bias in your results, but this might not always be possible.

Simple Random Sampling

In this method, every household who took part in the project has an equal chance of being selected in the sample. You can use different methods to randomly select the households, such as drawing names or numbers from a hat, or using an online random number generator (www.random.org).

For example, your sample size is 50 from a total population of 200 households. Write the name of each household in a separate piece of paper and put it into a container. Randomly select 50 names from the container.

Systematic Random Sampling

In this method, households are selected at particular intervals. The interval can be calculated by dividing the total number of households who took part in the project by the number of households to be selected (sample size).

For example:

- Your sample size is 100 households from a total population of 1,000 households
- $1,000 \div 100 = 10$ households
- From a list of the 1,000 households, begin at a random household on the list, and select every 10th household to be sampled

Cluster Random Sampling

In this method, the population is divided into clusters or groups, and some of these are then chosen by simple random sampling. It is a good method to use for large projects. Samples taken from households of the same street or households within the same tribe are an example of cluster sampling.

For example, an organization wants to find out the effectiveness of a HWT technology in the project area. It would be too costly and take too long to survey every household in the project. Instead, 50 households are randomly selected from all households using a local pond as their water source. These households using the pond water are considered as a cluster sampling.

Convenience Sampling

Convenience sampling does not give you a random sample of the population because households are only selected if they can be accessed easily and conveniently. Many projects often use convenience sampling instead of random sampling due to limited time and resources.

For example, this may include the first ten households on a street or the first row of people in a meeting.

2.7 Determine Key Milestones

The concept of milestones in project planning was originally derived from engineering highways. A milestone or kilometre sign was placed along a road at regular intervals. This gave the traveler a better idea of the path being followed and the remaining distance to the desired destination.

Similarly, a milestone within the planning process indicates what achievements need to be reached in order to meet the final goal. In planning your milestones, it is best to begin with the end in mind to determine the key milestones that have to be accomplished prior to completing the final report.

The example below shows the key milestones on top and the major activities below starting from today and extending to the completion of the water quality testing program.

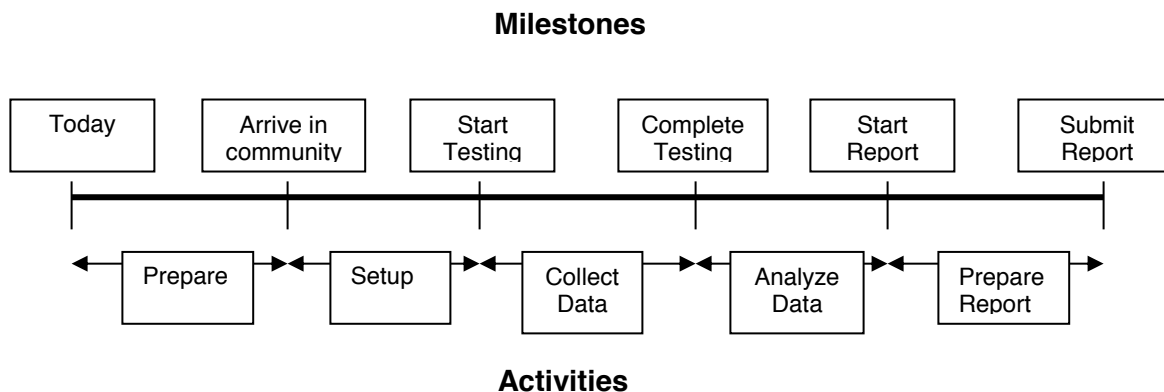

This method of displaying the milestones is a useful tool to help visualize the entire plan and to understand the steps necessary to complete the work. By breaking down your water quality testing program into milestones, you can then focus on the specific activities required to complete each portion of the program. Generating the specific list of activities to achieve each milestone is the next step of the planning process.

2.8 Identify Activities

Activities are the specific tasks that need to be done to achieve a milestone. Many activities will occur at the same time. It is not always necessary to finish one activity before starting the next one. For example, preparation activities include all the things that should be done before your arrival in a community. Examples of some of these activities may be:

1. Acquire water testing equipment and supplies
 - Identify local or international manufacturers of equipment and consumable items
 - Purchase all equipment and consumables
 - Develop an inventory checklist
 - Find a space where water quality testing will be conducted
 - Prepare testing procedures
 - Provide training to staff on how to use the equipment
 - Practice using the equipment to conduct water quality tests
2. Develop survey tools
 - Determine sample sizes
 - Identify households or locations where water samples will be collected
 - Develop a household visit checklist and train staff on how to conduct themselves in households
 - Develop sanitary inspection forms and train staff on how to use them
3. Data management plan
 - Determine what data will be recorded
 - Determine how data will be recorded
 - Create data collection forms
 - Determine process for compiling the data collected from different sources
 - Determine who will analyze the data and how the results will be reported

2.9 Assign Responsibilities

Once the list of activities has been developed, the next step is to assign responsibility for each activity. In the case of larger projects, there may be several people involved and each needs to know their role and how they will work together. A RACI chart is a project management tool that helps clarify the different roles in a project. RACI stands for 'responsibility', 'action', 'consult' and 'inform' respectively.

R = Responsibility

The 'R' role is held by just one person. This is the individual who is ultimately responsible for that activity being completed on time and on budget. Even if several other people will be working on that activity, only one person is labeled with an 'R'.

A = Action

All the people who will need to take some action to complete that activity is assigned an 'A' in the RACI chart. Anyone and everyone who will take some action are labeled with an 'A' for that activity.

C = Consult

This refers to those people who must be consulted and a reply is required from those people. For example, if approval of funds is required then the person who will give the approval are labeled with a 'C'.

I = Inform

With many activities there are a number of people that need to be informed, although they do not need to give a reply. This may be the recipients of progress reports, draft results, etc. These people are labeled with an 'I' in the RACI chart.

Note that the same person can be included in more than one way (i.e. 'A' and 'I'). It is important that each person understands and agrees to the responsibilities assigned to them, and be prepared to report progress back to the team as the activities move forward.

Example RACI Chart

Activities	R	A	C	I
1. Water test kit and supplies:				
Identify manufacturers of equipment and supplies	Mr. X			Ms. Y
Purchase all equipment and supplies	Mr. X			Ms. Y
Develop inventory checklist	Mr. X			Ms. Y
Prepare testing protocol	Ms. Y		Mr. X	
Provide training to staff on how to use the equipment	Ms. Y	Mr. X Ms. W		
Practice conducting water quality tests	Ms. Y	Mr. X Ms. W		

2.10 Develop Time and Cost Estimates

The final step is to estimate the time and cost necessary to complete each activity. By using the list of activities as a 'project breakdown' it is much easier to estimate the time required and cost for each activity.

Normally, the cost and time is estimated, or at least agreed to, by the person who is ultimately responsible for the activity. Water quality testing is often more complex and takes longer than we originally estimate, especially for the first project. It is best to give yourself some extra time in your plan.

Example Time Estimate

Activities	Week				
	1	2	3	4	5
1. Preparation					
2. Set up					
3. Collect data					
4. Analyze data					
5. Prepare final report					

Support cost estimates whenever possible with actual quotes (e.g., for testing equipment and consumable items). A budget should be prepared to include all capital costs (e.g., equipment) and ongoing expenses including transportation and human resources.

Example Budget for Testing 30 Ceramic Filters

Activities	Cost (US\$)
1. Portable Test Kit (includes enough consumable items needed for tests)	\$2,500.00
2. Office Supplies	
Paper	\$15.00
Photocopies	\$30.00
Printing	\$50.00
Maps	\$10.00
3. Field Work	
Local transportation to project (6 days at \$20/day)	\$120.00
Test equipment and supplies	\$120.00
Refreshment for community meetings	\$120.00
3. Human Resources	
Staff daily allowances (1 team leader, 3 members, 1 driver)	\$180.00
Total Costs	\$3,145.00
Contingencies 10%	\$314.50
Grand total	\$3,459.50

2.11 Summary of Key Information

- It is important to have a plan before you start doing water quality testing. Planning in advance and thinking through the process will save time, lower costs and prevent surprises during the project. Moreover, it gives a basis for the financial and human resources that will be needed to carry out your testing.
- Planning for a water quality testing program should be done by the people who will be involved in the project.
- The main steps in the planning process are as follows:
 1. Review the need – Why do you need to do water quality testing?
 2. Develop your objectives – What are your objectives for testing the water quality?
 3. Identify the test parameters – What water quality parameters are you going to test for?
 4. Identify the test methods – How are you going to do the testing?
 5. Design your sampling plan – How many water samples do you need? Where do you take them from?
 6. Determine your key milestones – What achievements need to be reached in order to meet the final goal?
 7. Identify your activities – What specific tasks need to be done?
 8. Set out responsibilities – Who is going to do what?
 9. Develop time and cost estimates – What is the time and cost necessary to complete each activity?
- Generally, the priority water quality parameters to test for are:
 - *E. coli* and/or thermotolerant coliforms (see Section 7: Testing for Microbiological Parameters)
 - Turbidity (see Section 5: Testing for Physical Parameters)
 - Arsenic (see Section 6: Testing for Chemical Parameters)
 - Fluoride (see Section 6: Testing for Chemical Parameters)
 - Nitrate (see Section 6: Testing for Chemical Parameters)
 - Free residual chlorine and pH, if chlorine disinfection is used (see Section 6: Testing for Chemical Parameters)

2.12 References

UNICEF (2008). UNICEF Handbook on Water Quality. UNICEF, New York, USA. Available at: www.unicef.org/wash/files/WQ_Handbook_final_signed_16_April_2008.pdf

World Health Organization (2012). Rapid Assessment of Drinking-Water Quality: A Handbook for Implementation. WHO, Geneva, Switzerland. Available at: www.who.int/water_sanitation_health/publications/2012/rapid_assessment/en/index.html

Introduction to Drinking Water Quality Testing

Section 3: Sanitary Inspections

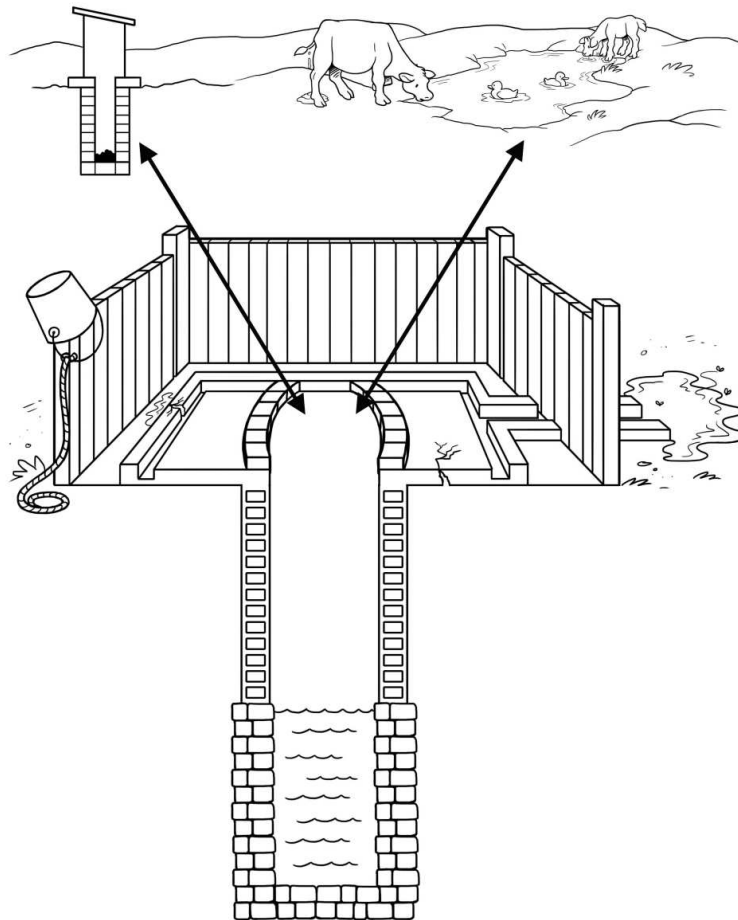

Table of Contents

Section 3: Sanitary Inspections.....	i
3.1 Introduction	1
3.2 What is a Sanitary Inspection?	2
3.3 When to do a Sanitary Inspection	2
3.4 How to do a Sanitary Inspection	3
3.5 Interpreting the Results.....	5
3.6 Community and Household Education.....	5
3.7 Visual Inspections.....	6
3.8 Summary of Key Information	6
3.9 References	7



3.1 Introduction

Sanitary inspections are a simple, inexpensive, and practical method to help communities and households understand and manage the quality of their drinking water. Sanitary inspections combined with water quality testing can be used to identify the most important sources of contamination and appropriate actions to improve the safety of drinking water.

Water quality testing alone does not guarantee safe drinking water. Periodic testing only gives you a snapshot of the water quality. It provides limited information on the source of contamination, and it may not identify important seasonal changes in water quality. Identifying the causes of water contamination and appropriate actions to prevent contamination is only possible if information is available on the sources and pathways of contaminants. This information can be provided by sanitary inspections (UNICEF, 2008).

Sanitary inspections are especially useful in assessing and monitoring small community managed drinking water supplies (e.g., simple piped water systems, boreholes with mechanized or hand pumps, dug wells, protected springs) and household water treatment and storage systems. Regular water quality testing is often not possible in these cases, and sanitary inspections can help to assess the safety of the drinking water (WHO, 2011). Research by Mushi et al. (2012) showed that sanitary inspections (using the procedure developed by the World Health Organization [WHO]) were able to predict the levels of bacterial fecal pollution in wells used for drinking water.

Comparison of Water Testing and Sanitary Inspections for Assessing Water Quality

Water Quality Testing	Sanitary Inspection
Testing can be expensive, requires equipment and competent, skilled staff, and therefore is not always easy to perform regularly or routinely.	Sanitary inspection is cheap, requires no equipment or highly-skilled staff, and may easily be performed regularly or routinely.
Testing gives only a snapshot – a record of the water quality at the time of sampling.	Sanitary inspection can reveal conditions or practices that may cause short-term contamination incidents or long-term contamination.
Testing will indicate whether a water sample is contaminated, but will not usually identify the source of contamination.	Sanitary inspection reveals the most obvious possible sources of contamination, but may not reveal all sources of contamination (e.g., contamination of groundwater). Sanitary inspection does not provide confirmation of whether contamination has occurred.
Testing provides data about the physical, chemical and microbiological quality of water samples.	Sanitary inspection usually identifies risks that may affect the microbiological and physical quality of water. Risks to the chemical quality of water are not usually identified.

(Adapted from WHO, 2012)

3.2 What is a Sanitary Inspection?

A sanitary inspection is an on-site inspection of a water supply to identify actual and potential sources of contamination. The physical structure and operation of the systems, as well as external factors (such as latrine location) are evaluated. This information can be used to select appropriate actions to protect or improve the water supply (WHO, nd).

Sanitary inspections usually focus on sources of microbiological contamination, mainly fecal contamination from people and animals. However, in some cases inspections can identify chemical hazards from local industries or agricultural activity. For example, a sanitary inspection could identify intensive fertilization near a surface water source intake or effluents from a tannery near a water source (WHO, nd).

3.3 When to do a Sanitary Inspection

Sanitary inspections should be done for all new sources of water (including boreholes, dug wells and protected springs) before they are used for drinking water, and on a regular basis once the source is in operation. The following table suggests minimum annual frequencies of sanitary inspections that should be done by the community (e.g., Water User Groups), water supply agencies (e.g., nongovernmental organizations [NGO] or private companies who implement water supply and treatment projects), and government surveillance agencies (e.g., Ministry of Environment, Ministry of Health)

Training community members to do sanitary inspections on their own water supplies can allow them to occur more frequently. It is also important to train community members on how to take appropriate corrective actions for risks that they identify.

Suggested Minimum Frequency of Sanitary Inspections

Water source and supply	Community ^a	Water Supply Agency ^b	Surveillance Agency ^{a,b,c}
Dug well (without windlass)	6 times/year	-	1 time/year ^d
Dug well (with windlass)	6 times/year	-	1 time/year ^d
Dug well with hand pump	4 times/year	-	1 time/year ^d
Shallow and deep tube well with hand pump	4 times/year	-	1 time/year ^d
Rainwater harvesting	4 times/year	-	1 time/year ^d
Gravity spring	4 times/year	-	1 time/year ^d
Piped supply: groundwater with and without chlorination	-	1 time/year	1 time/year
Piped supply: treated surface water with chlorination			
Population <5,000	12 times/year	1 time/year	1 time/year
Population 5,000-20,000	-	2 times/year	1 time/year
Distribution of piped supply ^e	-	12 times/year	1 time/year

^a For family-owned water supplies (e.g., dug wells with or without hand pumps), the family is responsible for sanitary inspections, with support from the surveillance agency.

^b All new sources should be inspected before commissioning.

^c Under emergency conditions, such as onset of epidemic diseases, inspection should take place immediately.

^d Where it is impractical to inspect all such facilities, a statistically significant sample should be inspected.

^e Public tap stands are cleaned by the community if the population is less than 5,000. The water supply agency usually maintains the distribution system and tap stands if the population is between 5,000 and 20,000.

(Adapted from WHO, 2007)

3.4 How to do a Sanitary Inspection

The procedure for doing a sanitary inspection was developed by the WHO as part of water safety plans. Sanitary inspections use standardized forms for observations and interviews with a scoring system to quantify overall risk. The forms usually have a list of 10 questions with “yes” or “no” answers. The questions are written so that “yes” answers indicate that there is a risk of contamination and “no” answers indicate that there is no risk. Each “yes” answer scores one point and each “no” answer scores zero points. At the end of the inspection the points are added up to get a score out of 10. The higher the total score, the greater the risk of contamination (WHO, no date).

Sanitary Inspection Score and Risk

Sanitary Inspection Score	Risk of Contamination
9-10	Very high
6-8	High
3-5	Medium
0-2	Low

Example sanitary inspection forms for different water sources are given in Appendix 1: Sanitary Inspection Forms. You can modify these forms to consider local conditions and language. The forms should also be easy for inspectors to use and understand. They can be adapted to use simple text and illustrations for inspectors with low literacy levels.

The results of sanitary inspections and the actions that need to be taken to protect and improve the water quality should be discussed with the household and community. For example, in the following illustration of an open well, possible actions to protect the water source could be to:

- Relocate a latrine if it is too close to the water source
- Ensure that animals do not have access to the water source
- Fix the cracks around the well platform
- Improve the drainage around the well platform
- Use a clean water collection container that is stored in a safe location

Training is essential to conduct effective and consistent sanitary inspections. Both project staff and community members can be trained to do sanitary inspections. Even community members with no formal technical background have been successfully trained in sanitary inspection. Local inspectors are often very effective as they are direct stakeholders in their water systems, are accountable to their peers and local authorities, and are in a position to carry out inspections on a regular basis (UNICEF, 2008). If you are using community members to conduct sanitary inspections, it is also important to train them on how to take appropriate corrective actions for risks that they identify.

Some common problems that prevent community groups or other organizations from conducting effective sanitary inspections include:

- No standardized method for conducting the inspection
- Interpretation of on-site observations can vary between inspectors
- Data are difficult to quantify or compare due to subjectivity in interpretation and 'observational' style
- No effort made to analyze data in order to investigate general trends or common problems

These problems highlight the need for good planning, management, and training to make sure that sanitary inspections are an effective tool for helping to ensure safe drinking water.

Example Sanitary Inspection of an Open Well

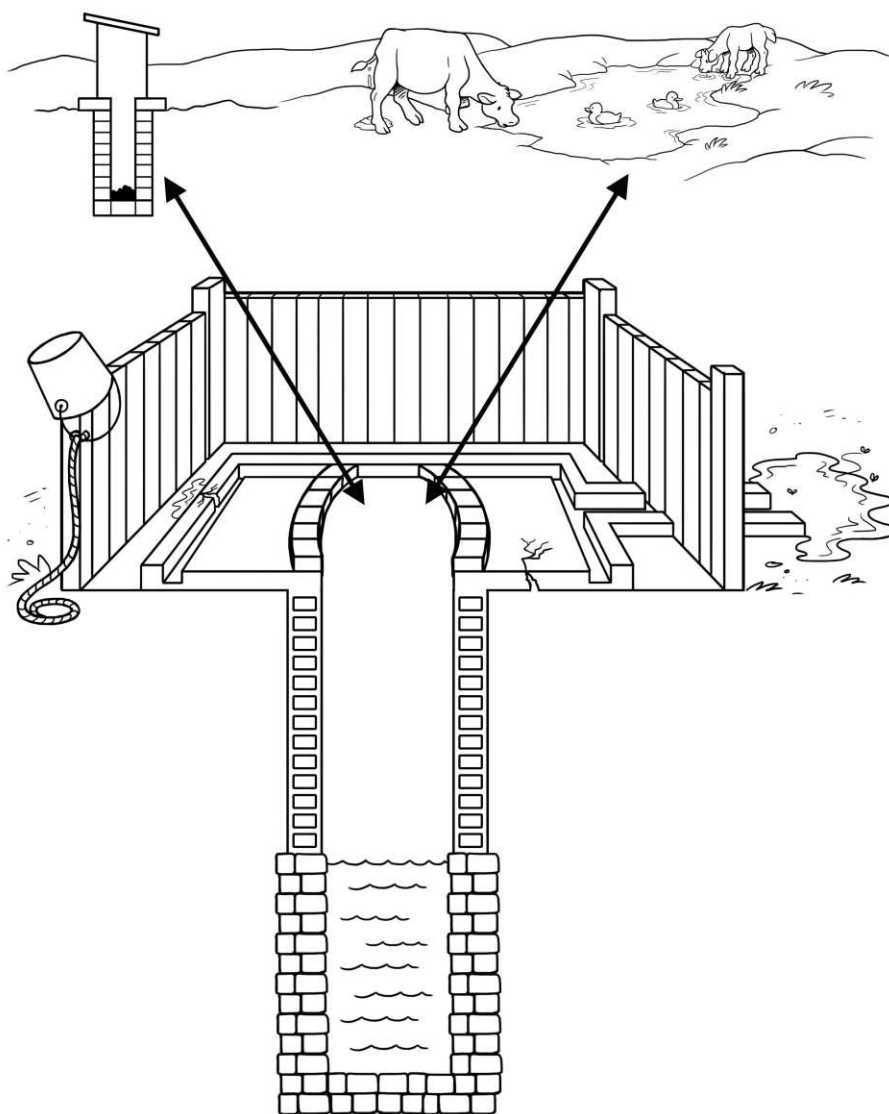

3.5 Interpreting the Results

Sometimes water quality testing is done at the same time as a sanitary inspection. This is called a sanitary survey. Combining the results of a sanitary inspection with water quality data can be useful to identify the most important causes of contamination and actions that can be taken to improve the situation. For instance, the results may help you to determine whether on-site or off-site sanitation is causing drinking water contamination. This analysis may also identify other factors associated with contamination, such as heavy rainfall.

Combining the analysis of a sanitary inspection with water quality data is especially useful in assessing household water management systems. Microbiological water quality data is often limited at the household level, and sanitary inspection risk scoring therefore becomes an important consideration in assessing household water systems, their management, and priority for actions to improve the situation. An example of a combined system to assess risk and prioritize actions for household water systems is shown in the following table (WHO, 2011).

Example of Assessing the Action Priorities for Household Drinking Water Using Microbiological Water Quality Results and the Sanitary Inspection Score¹

		Sanitary Inspection Risk Score			
		0-2	3-5	6-8	9-10
<i>E. coli</i> (CFU/100 mL) ²	<1				
	1-10				
	11-100				
	>100				

Low risk: No action required	Intermediate risk: Low action priority	High risk: Higher action priority	Very high risk: Urgent action required
---------------------------------	---	--------------------------------------	---

¹ Where there is a potential discrepancy between the results of water quality testing and the sanitary inspection, further follow-up is required.

² CFU = Colony Forming Units (See Section 7: Testing for Microbiological Parameters for more information)

(WHO, 2011)

3.6 Community and Household Education

Sanitary inspections may also include health promotion and education activities to improve water, sanitation and hygiene behaviour. An advantage of sanitary inspection is that the results can be discussed at the time of inspection with users and community members. This can help them to understand the identified risks and inspectors can provide on-site advice. The involvement of community members in the sanitary inspection can increase their willingness to take corrective actions (WHO, 2011 and 2012).

3.7 Visual Inspections

A visual inspection is similar to a sanitary inspection, but it is less structured. It provides qualitative data that is collected by observation, and then reported in spoken or written form. The technique requires those who undertake inspections to have a basic knowledge and understanding of public health principles, and to be thorough and professional by nature. For example, visual inspection may be used by community health promoters to assess domestic hygiene practices and the risks affecting the water quality within the home. Visual inspection includes observing how water is stored, handled and used within individual homes, so that unhygienic practices can be identified (WHO, 2012).

Standard reporting forms may be used for visual inspections. The use of standard forms encourages objective assessment, so that data obtained by different inspectors or in different areas can be compared directly (WHO, 2012).

CAWST provides some visual inspection forms as part of biosand filter monitoring. These can be found at: http://resources.cawst.org/package/monitoring-biosand-filter-projects-manual_en

3.8 Summary of Key Information

- Sanitary inspections are a simple, inexpensive, and practical method to help communities and households understand and manage the quality of their drinking water.
- A sanitary inspection is an on-site inspection of a water supply to identify actual and potential sources of contamination.
- Sanitary inspections usually focus on sources of microbiological contamination, mainly fecal contamination from people and animals.
- Sanitary inspections use standardized forms for observations and interviews with a scoring system to quantify overall risk.
- Example sanitary inspection forms for different water sources are given in Appendix 1. You can modify these forms to consider local conditions and language.
- The results of sanitary inspections and the actions that need to be taken to protect and improve the water quality should be discussed with the household and community.
- Training is essential to conduct effective and consistent sanitary inspections. Both project staff and community members can be trained to do sanitary inspections.
- Sometimes water quality testing is done at the same time as a sanitary inspection. This is called a sanitary survey. Combining the results of a sanitary inspection with water quality data can be useful to identify the most important causes of contamination and actions that can be taken to improve the situation.
- Sanitary inspections may also include health promotion and education activities to improve water, sanitation and hygiene behaviour.
- A visual inspection is similar to a sanitary inspection, but it is less structured. It provides qualitative data that is collected by observation, and then reported in spoken or written form.

3.9 References

Mushi, D., Byamukama, D., Kirschner, A., Mach, R., K. Brunner and A. Farnleitner. Sanitary inspection of wells using risk-of-contamination scoring indicates a high predictive ability for bacterial faecal pollution in the peri-urban tropical lowlands of Dar es Salaam, Tanzania. *J Water Health*. 2012 June; 10(2): 236–243. Available at: www.ncbi.nlm.nih.gov/pmc/articles/PMC3393635/

UNICEF (2008). UNICEF Handbook on Water Quality. UNICEF, New York, USA. Available at: www.unicef.org/wash/files/WQ_Handbook_final_signed_16_April_2008.pdf

World Health Organization (no date). Fact Sheet 2.1: Sanitary Inspections. WHO, Geneva, Switzerland. Available at: www.who.int/water_sanitation_health/emergencies/envsanfactsheets/en/index1.html

World Health Organization (1997). Guidelines for Drinking Water Quality, Second Edition, Volume 3, Surveillance and Control of Community Supplies. WHO, Geneva, Switzerland. Available at: www.who.int/water_sanitation_health/dwq/gdwq2v1/en/index2.html

World Health Organization (2005). Water Safety Plans: Managing Drinking-Water Quality from Catchment to Consumer. WHO, Geneva Switzerland. Available at: www.who.int/water_sanitation_health/dwq/wsp0506/en/index.html

World Health Organization (2011). Guidelines for Drinking-Water Quality, Fourth Edition. WHO, Geneva, Switzerland. Available at: www.who.int/water_sanitation_health/dwq/secondaddendum20081119.pdf

World Health Organization (2012). Rapid Assessment of Drinking-Water Quality: A Handbook for Implementation. WHO, Geneva, Switzerland. Available at: www.who.int/water_sanitation_health/publications/2012/rapid_assessment/en/index.html

Introduction to Drinking Water Quality Testing

Section 4: Water Sampling and Quality Control

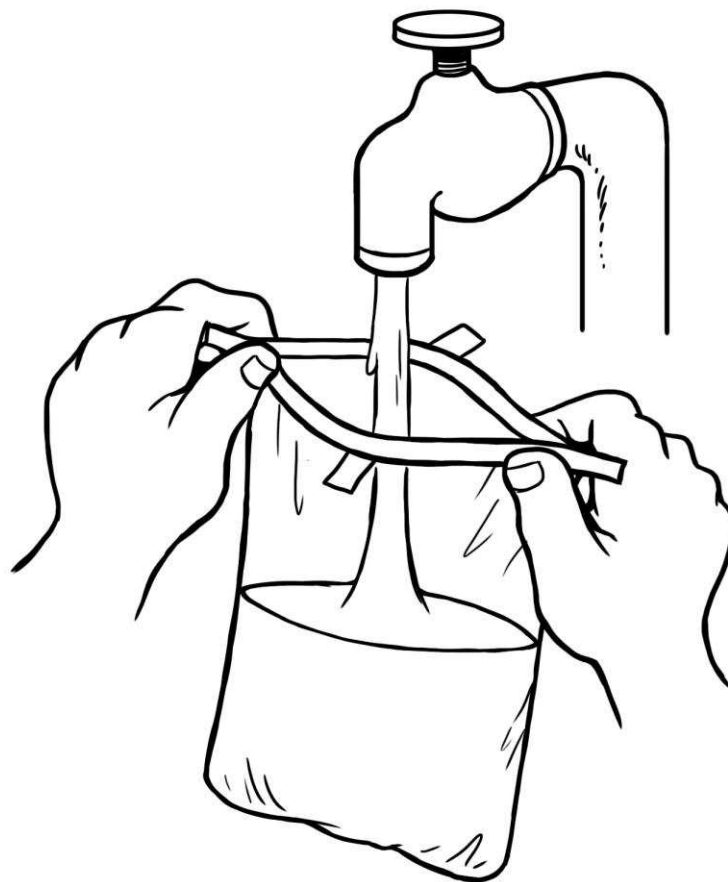

Table of Contents

Section 4: Water Sampling and Quality Control.....	i
4.1 Introduction	1
4.2 How to Collect Water Samples	1
4.2.1 Cleaning and Sterilizing Sample Containers.....	2
4.2.2 Using Additives or Preservatives	3
4.2.3 Sampling Surface Water	3
4.2.4 Sampling an Open Well or Tank	4
4.2.5 Sampling a Tap.....	5
4.2.6 Sampling a Hand Pump.....	6
4.2.7 Sampling a Protected Spring	7
4.2.8 Sampling a Transport or Household Storage Container	8
4.2.9 Sampling a Household Water Treatment Technology.....	8
4.3 How to Transport Water Samples.....	11
4.4 How to Dilute a Water Sample.....	12
4.5 Quality Assurance and Quality Control	13
4.5.1 Selecting Equipment and Products	15
4.5.2 Equipment Calibration	15
4.5.3 Quality of Products.....	15
4.5.4 Unequal Distribution of Microorganisms in a Water Sample	16
4.5.5 Secondary Contamination	16
4.5.6 Duplicate Samples	18
4.5.7 Controls: Blank Samples and True Positives	19
4.6 Health and Safety	19
4.7 Summary of Key Information	20
4.8 References	21



4.1 Introduction

This section discusses how many water samples you should take depending on your needs; how to collect and transport water samples from different sources; different actions that you can take to ensure quality control; and the importance of health and safety.

4.2 How to Collect Water Samples

It is important to collect water samples under normal, everyday conditions, in order to gain a representative sample. Proper procedures for collecting samples must also be observed. Technicians should be trained since the way samples are collected can influence the test results.

Samples should be collected in a glass or plastic container with a screw cap that will maintain a tight seal, even after they have been sterilized many times. A reusable sample container is usually provided as part of portable field kits.



Tip: Plastic baby bottles can be used as a sample container. They are usually easy to buy in urban areas and are made of heat resistant plastic that can be sterilized many times without affecting the quality of the bottle.

Disposable and one-time use sample bags are another option to collect water samples, although they are more expensive than reusable containers (see the Whirl-Pak® Product Sheet in Appendix 1 for more details).

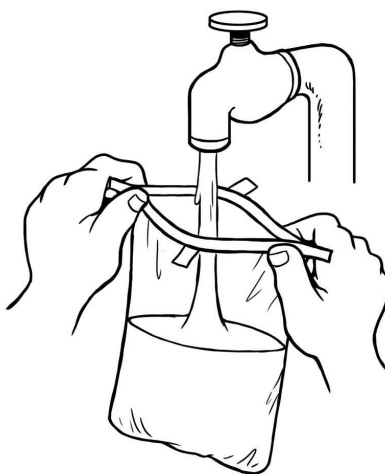

Using a Whirl-Pak® disposable bag to collect a water sample

More water should be collected than needed (minimum 250 mL), in case you make a mistake or if multiple tests are required.

Label every sample container before filling the container. The sample label should have information about:

- Sample location (e.g., household, source)
- Sample description (e.g., inlet water, storage bucket water)
- ID number
- Date and time
- Initials of the person collecting the sample
- Other relevant information (e.g., project name, test to be performed)

You need to take care to avoid contaminating the container and the water sample. The basic procedure for collecting a drinking water sample is as follows:

- Use sample containers only for water samples and never for the storage of chemicals or other liquids.
- Use sample containers for microbiological testing only for that purpose.
- Use sterile sample containers for microbiological testing. Sample containers for chemical and physical testing need to be clean, but not sterile.
- Label the container before sampling.
- Wash and/or disinfect your hands before opening the sample container or wear disposable gloves if available.
- Do not touch the inside of the sample container or cap with your fingers or any other object.
- Do not rinse the sample container since it is sterile.
- Keep the sample container cap in a clean place (not on the ground) to prevent contamination at any time that the sample container is open.

(Adapted from UNEP/WHO, 1996)

4.2.1 *Cleaning and Sterilizing Sample Containers*

You can reuse glass or heat resistant plastic sample containers. To prepare the containers, they should be washed with soap and rinsed at least three times (five is better) with distilled water to remove any residue. If distilled water is not available, clean chlorine-free water may be used (e.g., filtered and then boiled) (UNEP/WHO, 1996).

After washing, sample containers for microbiological testing need to be sterilized. Sample containers for physical and chemical tests need to be clean, but not sterilized. However, often the same water sample is used for physical, chemical and microbiological testing, so then the container must be sterilized using one of the following methods:

- Conventional oven: Heat at 180°C for 30 minutes (WHO, 2012)
- Boiling: Boil for 10 minutes (CDC, 2010 and WHO, 2012)
- Autoclave: Heat at 121°C for 20 minutes (WHO, 1997)
- Pressure cooker: Heat for at least 30 minutes (WHO, 1997)

Never use bleach, chlorine or disinfectants that may leave a residue without properly rinsing (with distilled water) or boiling the containers afterwards. The residue may affect your results by inhibiting or killing the bacteria you are trying to test for.

4.2.2 Using Additives or Preservatives

Whenever chlorine is used for disinfection, chlorine residual may be present in the water after sampling and will continue to act on any microorganisms in the sample. Therefore, the results of any microbiological test may not show the true contamination of the water. If you suspect or know that the water sample has been chlorinated, then you need to add sodium thiosulphate to the sample. The sodium thiosulphate immediately inactivates any residual chlorine but does not affect the microorganisms that may be present.

Sodium thiosulphate should be added to the sample container, after it has been sterilized. For 200 mL samples, four or five drops of liquid sodium thiosulphate solution (100 g/L) should be added to each clean and sterilized sample container (WHO, 1997). Some manufacturers may have already added sodium thiosulphate to disposable sample containers (e.g., Whirl-Pak® sample bags).

Preservatives may also be required for testing other chemicals, such as ammonia or cyanide. The manufacturer of portable test kits or a commercial laboratory will usually include the preservative along with instructions on how to use it properly.

4.2.3 Sampling Surface Water

Lakes and reservoirs can be subject to several influences that cause water quality to vary from place to place and from time to time. Where feeder streams or effluents enter lakes or reservoirs there may be local areas where the incoming water is concentrated, because it has not yet mixed with the main water body. Isolated bays and narrow inlets of lakes are frequently poorly mixed and may contain water of a different quality from that of the rest of the lake (UNEP/WHO, 1996).

For rivers or other moving water, you should try to obtain samples from a point where the water is well mixed and representative of the drinking water supply. Do not take samples that are too near the bank, too far from the point of where the drinking water is taken, or at a depth above/below the point of where the drinking water is taken.

Surface water quality can also change depending on the time of day or season. It is important to sample at the same time of the day and record the weather conditions when you are taking your sample.

It may be possible to take the sample by hand if it is easy to get to the water. In many cases it may be inconvenient or dangerous to enter the water. In these cases, you may need to tie your container to a piece of wire or rope and throw it into the water. A bridge is an excellent place at which to take a sample, but only if it is close to where people get their drinking water.

To sample a surface water source:

1. Carefully remove the cap from the container and put it facing up in a clean place or ask somebody to hold it. Take care to prevent dust from entering the container or anything else that may contaminate the sample.
2. Hold the sample container firmly and dip the open mouth of the container into the water.
3. Lower the container about 20 cm below the surface of the water and scoop up the water sample. This scooping action ensures that no external contamination enters the sample container. In areas where the water is moving (e.g., rivers), the sample should be taken against the direction of the flow of water.
4. Lift the sample container carefully and place on a clean surface where it cannot be knocked over. If the container is completely full, pour out a little water to leave an air space in the container. This allows space for mixing the water sample before analysis. Put the cap back on the container.

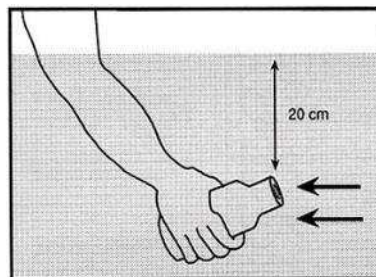

(Adapted from WHO, 1997)

4.2.4 Sampling an Open Well or Tank

1. Prepare the sample container. Use string, rope or cable to attach a weight (e.g., small rock) to the container.

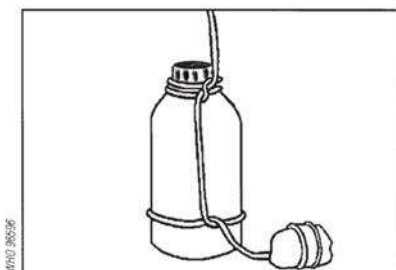

2. Take a 20 m length of string, rolled around a stick, and tie it to the container. Open the container as described above.

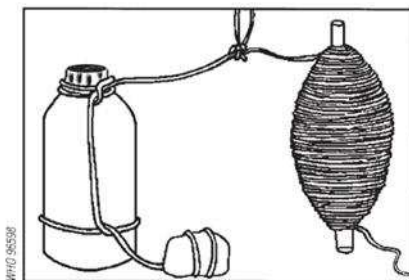

3. Carefully remove the cap from the container and put it facing up in a clean place or ask somebody to hold it. Take care to prevent dust from entering the container or anything else that may contaminate the sample.

- Lower the weighted sample container into the well or tank, unwinding the string slowly. Do not allow the container to touch the sides of the well or tank because it may pick up dirt and contaminate the sample.

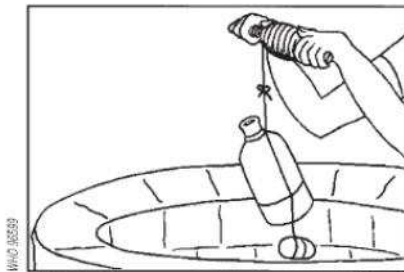

- Immerse the container completely in the water and continue to lower it below the surface of the water (about 20 cm although this can be difficult to judge). Do not allow the container to touch the bottom of the well or disturb any sediment.
- Once the container is full, bring it up by rewinding the string around the stick. Lift the container carefully and place on a clean surface where it cannot be knocked over. If the container is completely full, pour out a little water to leave an air space in the container. This allows space for mixing the water sample before analysis. Put the cap back on the container.

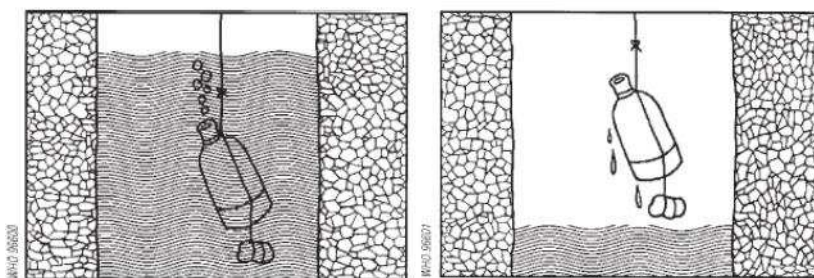

(Adapted from WHO, 1997)

4.2.5 Sampling a Tap

- Remove any attachments (e.g., nozzles, pipes, screens) from the tap. These attachments are a frequent source of contamination.
- Optional – Use a clean cloth to wipe the tap and to remove any dirt. Sterilize the inside and outside of the tap for 1 minute. Pour alcohol on the outlet and flame it with a lighter or use tweezers to hold an alcohol-soaked cotton swab that is lit on fire. If the tap is made of plastic, then use an alcohol-soaked cotton swab that is NOT lit on fire, or else the plastic will melt! Sterilizing the tap will tell you the actual water quality. Not sterilizing the tap will tell you the water quality that people are drinking.

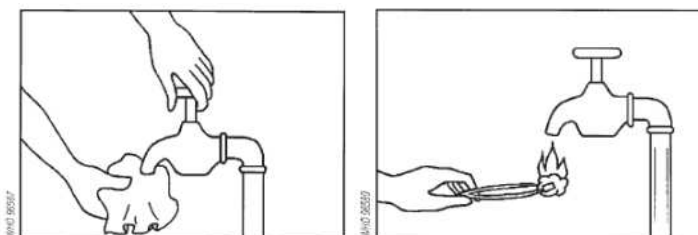

3. Open the tap before sampling. Carefully turn on the tap and allow water to flow at a moderate rate for 2-3 minutes to clear out any deposits in the pipes.



Tip: It is important not to waste water resources when sampling. You can capture the flow water in a container for future use.



4. Carefully remove the cap from the container and put it facing up in a clean place or ask somebody to hold it. Take care to prevent dust from entering the container or anything else that may contaminate the sample. Hold the sample container under the water flow to fill it. Leave an air space in the container. This allows space for mixing the water sample before analysis. Put the cap back on the container.

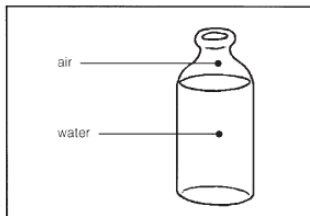
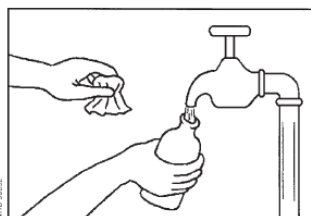

(Adapted from WHO, 1997)

4.2.6 Sampling a Hand Pump

1. Remove any attachments (e.g., nozzles, pipes, screens) from the pump outlet. These attachments are a frequent source of contamination.

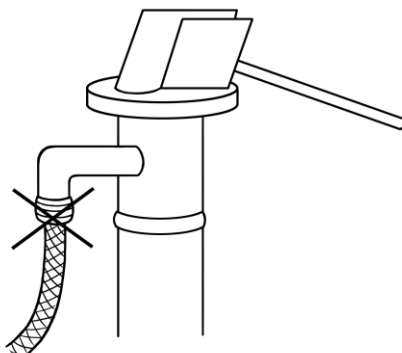

- Optional - Use a clean cloth to wipe the pump outlet and to remove any dirt or grease. Sterilize the inside and outside of the pump outlet for 1 minute. Pour alcohol on the outlet and flame it with a lighter or use tweezers to hold an alcohol-soaked cotton swab that is burning. Sterilizing the pump outlet will tell you the actual water quality. Not sterilizing the outlet will tell you the water quality that people are drinking.

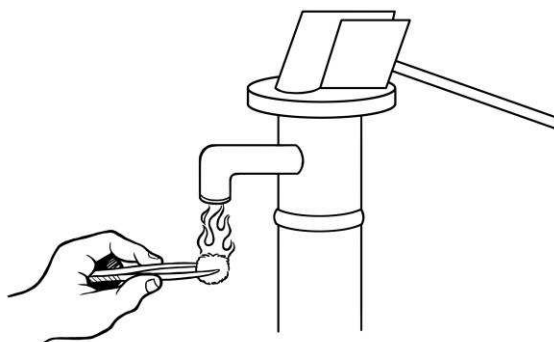

- Pump the water for four to five minutes (it depends on depth of the well, it may take up to 10 minutes) to remove standing water from the plumbing system or rising main of the pump. You can usually tell the standing water is removed when colder water comes through the pump. Take the water sample as soon as possible after pumping.



Tip: It is important not to waste water resources when sampling. You can capture the flow water in a container for future use.

- Carefully remove the cap from the container and put it facing up in a clean place or ask somebody to hold it. Take care to prevent dust from entering the container or anything else that may contaminate the sample. Hold the sample container under the water flow to fill it. Leave an air space in the container. This allows space for mixing the water sample before analysis. Put the cap back on the container.

(Adapted from DACAAR, 2013 and WHO, 1997)

4.2.7 Sampling a Protected Spring

Spring water sources are often protected by a concrete box to maintain good water quality. If the spring box has a lid for the storage tank, then collect your water sample following the procedure described in Section 4.2.4 Sampling an Open Well or Tank. If the concrete spring box has a tap, then collect your water sample following the procedure described in Section 4.2.5 Sampling a Tap.

4.2.8 *Sampling a Transport or Household Storage Container*

There are different types of transport and storage containers depending on where you live and what is locally available. Buckets or jerry cans are often used to transport water from the water source to the home. A safe storage container used in the home should have a lid or cover and a tap or narrow opening for pouring water out.

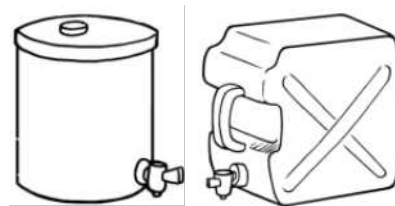

The sampling method depends on the purpose of the testing and the type of container used.

Option 1: To determine the quality of the water in the storage container

1. Remove the cap from the storage container and disinfect the outlet with an alcohol-soaked cotton swab lit on fire. If the storage container is made of plastic, then use an alcohol-soaked cotton swab that is NOT lit on fire, or else the plastic will melt! If the storage container is a bucket, then disinfect the lip of the bucket.
2. Pour off a little water to remove any remaining alcohol.
3. Pour the water into a sample container, making sure not to touch the outlet or lip of the storage container. Do not dip into the storage container or use a ladle or dipping cup. This may introduce contamination.

Option 2: To determine the quality of the water the householders are actually drinking

1. Use the tap or pour the water into a sample container. Do not disinfect the outlet or lip of the storage container. Do not dip into the storage container or use a ladle or dipping cup as this may introduce contamination.

4.2.9 *Sampling a Household Water Treatment Technology*

Many project implementers are concerned about the effectiveness of their household water treatment (HWT) technology and want to make sure that it is removing pathogens from drinking water. In this case, it is only worthwhile to carry out water quality testing if the technology is being operated and maintained properly. We know that any HWT technology will not produce good quality water if it is not being used correctly. Therefore, it is not worth spending money on water quality testing. Therefore, for regular water quality monitoring, any HWT technology which is not fulfilling the performance points should be recorded as “not operating properly” and no samples should be taken. However, there may be times when you do want to test a HWT technology that may not be operating properly to get an idea of the overall effectiveness of your project, such as during an evaluation.

There are two ways you can test the technology depending on what you want to know: (1) the actual water quality and the effectiveness HWT technology, or (2) the water quality that people are drinking.

Sedimentation

Natural settling or coagulants (natural or chemical) can be used to sediment drinking water. The length of time depends on the product used – chemical coagulants can work in just a few hours whereas natural settling can take 24 or more hours. All of these sedimentation methods normally use an open bucket. To take a water sample after sedimentation, you can simply pour the water from the bucket into your sample container. Follow the procedure from Section 4.2.8 Sampling a Transport or Household Storage Container.



Biosand Filters

The following eight key performance points for a biosand filter (BSF) must be checked before taking a water sample:

1. The filter was installed more than 30 days ago.
2. The filter is used at least once every day, with water from the same source every time.
3. The water poured into the BSF is clear.
4. The filter container does not have cracks and is not leaking.
5. There is a diffuser.
6. When the water stops running, the water surface is 5 cm (2") above the top of the sand.
7. The top of the sand is flat and level.
8. When the filter is full, the flow rate should be 400 mL or less per minute for the newest filter design (Version 10). For previous versions of the filter (Version 8 or 9), the flow rate should be 600 mL or less per minute.

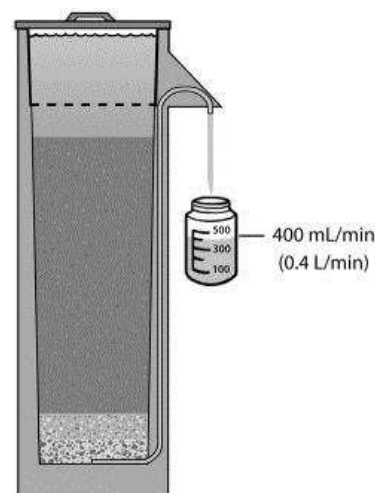

The following is the procedure for sampling a biosand filter:

1. Optional – Use a clean cloth to wipe the outlet and to remove any dirt. Sterilize the inside and outside of the outlet for 1 minute. A flame can be used for metal tube outlets and an alcohol-soaked cotton swab can be used for plastic tube outlets. Sterilizing the outlet will tell you the actual water quality and the effectiveness of the filter. Not sterilizing the outlet will tell you the water quality that people are actually drinking.
2. Pour a bucket of water into the filter until it is full. Note that the sample you are taking is actually the water that has been sitting in the filter during the pause period and it may not match the source of the water that was just poured into the filter.
3. Wait 10 minutes before taking the sample. After pouring water into a BSF, the first 1.5 to 2 litres from the outlet is the water that has been sitting in the drainage and separating layer, not the sand layer. This is not representative of the overall water quality, and therefore should not be tested. So, to flush out the first 2 litres, you will need to wait 10 minutes. Collecting a sample during the first 5 minutes is not recommended.

- Carefully remove the cap from the sample container and put it in a clean place. Take care to prevent dust from entering the container or anything else that may contaminate the sample. Hold the sample container under the outlet water flow to fill it. A small air space should be left to allow mixing before analysis. Put the cap back on the container.



Tip: It is important not to waste water resources when sampling. You can capture the flow water in a container for future use.

Ceramic Filters

The following two key performance points for a ceramic candle or pot filter must be checked before taking a water sample:

- No visible cracks or leaks in the ceramic filter.
- Flow rate should not be more than the manufacturer's specification. Generally, the flow rate for ceramic pot filters is not more than 3 L/hour, and for ceramic candle filters not more than 0.1-1 L/hour.

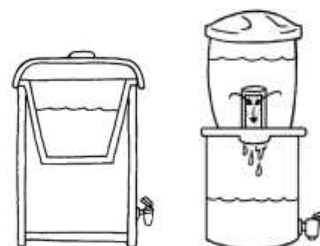

To sample a ceramic filter, follow the procedure from Section 4.2.5 Sampling a Tap.

Membrane Filters

There are different types of membrane filters that are commercially available. Before taking a water sample, you will need to check that the filter is being operated according to the manufacturer's instructions. The sampling procedure will depend on the design of the membrane filter. For example, the Family Lifestraw manufactured by Vestergaard Frandsen uses a tap that can be sampled using the procedure from Section 4.2.5 Sampling a Tap.

Solar Disinfection (SODIS)

The following five key performance points for SODIS must be checked before taking a water sample:

- Bottles are made of clear polyethylene terephthalate (PET) plastic.
- Size of bottles is not greater than 10 cm (4") in diameter.
- Bottles have a cap and do not leak.
- Bottles are not scratched and/or dirty.
- Bottles are kept at least 6 hours or more in the sun.



To take a sample of SODIS treated water, you can simply pour the water from the SODIS bottle into your sample container. Follow the procedure from Section 4.2.8 Sampling a Transport or Household Storage Container.

Boiling

Water needs to be boiled for at least 1 minute before taking sample. To take a sample of boiled water, you can simply pour the water from the pot into your sample container. Follow the procedure from Section 4.2.8 Sampling a Transport or Household Storage Container.

**Chlorine**

Water is usually chlorinated in a safe storage container. You need to wait at least 30 minutes after adding the chlorine before taking your water sample. To take a sample of chlorine treated water, you can simply pour the water from the storage container into your sample container. If you are doing microbiological testing, then sodium thiosulphate preservative first needs to be added to the container before you take the water sample (see details in Section 4.2.2 Adding Preservatives). Follow the procedure from Section 4.2.8 Sampling a Transport or Household Storage Container.

**4.3 How to Transport Water Samples**

In general, the time between sampling and testing should be kept to a minimum. For physical and chemical testing, the samples should be stored in a cool (4°C) and dark place to preserve the water quality. Residual chlorine, pH and turbidity should be tested immediately after sampling as they will change during storage and transport (WHO, 1997).

Bacteria do not generally survive well in water due to a variety of factors. The number of bacteria within a water sample rapidly die off 24 hours after it has been collected. Temperature can also affect die off within the water sample, with higher temperatures leading to greater die offs.

Samples for microbiological testing should be collected and placed on ice or ice packs in an insulated container (e.g., ice chest, cooler box) if they cannot be tested immediately; preferably held at <math><10^{\circ}\text{C}</math> during transit. If ice is not available, the transportation time must not take longer than 2 hours. Samples should be tested the same day or refrigerated overnight if necessary. If the time between collection and testing is more than 6 hours, the final report should include information on the conditions and duration of sample transport. Any samples older than 24 hours (from collection to testing) should not be tested (WHO, 1997).



Ice-pack or freezing mixture

Example Cooler Box for Transporting Water Samples
(Credit: WHO, 1997)

4.4 How to Dilute a Water Sample

You may have to dilute your water samples in the following situations:

- Microbiological testing – there are too many bacteria which makes it difficult to count, or the turbidity is too high and it clogs the filter paper
- Physical testing – turbidity is too high (out of range on the turbidimeter)
- Chemical testing – chemical concentration is too high (out of range of the test methods)
- Diluting your sample will reduce the concentration of the parameter – making it easier to measure and obtain more accurate results.

The following table provides an example method to calculate sample dilutions.

Sample Dilution Calculations

Volume of Sample to Use	Volume of Water to Add to Sample	Multiply Test Result by Dilution Factor
100 mL	0 mL	X 1
50 mL	50 mL	X 2
10 mL	90 mL	X 10
5 mL	95 mL	X 20
1 mL	99 mL	X 100
Total Volume = 100 mL		



Dilution Tips:

- Take a small sample volume with a sterile pipette. If pipettes are not available, then you can also use sterile syringes bought from a pharmacy.
- Working with small sample volumes can reduce the accuracy of results. As well, you need to be very careful on how you handle the sample.
- For physical and chemical testing, distilled water can be used for dilutions. If distilled water is not available, then you can use boiled water (e.g., clean rainwater, bottled water or spring water). Be careful of using battery water instead of distilled water. Battery water often contains some chemicals that may affect your test results.
- For microbiological testing, sterile water must be used for dilutions. Use either stock phosphate buffer solution or boiled water (e.g., clean rainwater, bottled water, or spring water). Do not use chlorinated water to dilute your samples since the chlorine residual will kill the microorganisms you are trying to test for. As well, do not use distilled water since it is harmful for the microorganisms.

4.5 Quality Assurance and Quality Control

Quality assurance and quality control (QA/QC) procedures are very important for water quality testing, especially when using field methods and testing for microorganisms. There exists the possibility of contamination in every step of the sampling and testing procedures. This section provides you with useful information on how to ensure that your water quality testing produces reliable, accurate and precise results.

The subject of quality assurance and quality control can be confusing. Different people may use different words to describe the same thing or the same word to describe different things. The following are some definitions of words that we use in this Manual.

Quality assurance – Aims to prevent errors by focusing on the processes used for water quality testing. The objective is to have clear and concise documentation of all sampling and testing procedures which can be monitored to ensure that quality is maintained. Quality assurance is a proactive process.

Quality control – Aims to find and eliminate causes of quality problems by checking products and equipment. Quality control is a reactive process.

Accurate – How close a measured value is to the actual (true) value.

Precise – How close the measured values are to each other. Precision depends primarily upon the test equipment and method, but also on the technician and quality control procedures.

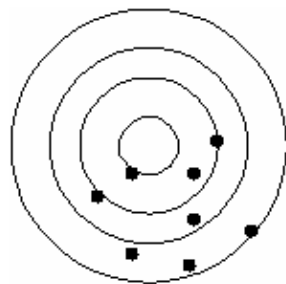

Not precise, not accurate

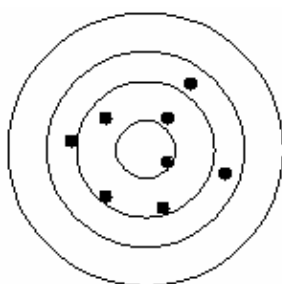

Not precise, more accurate

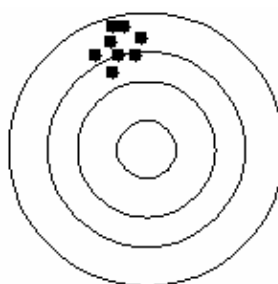

Precise, not accurate

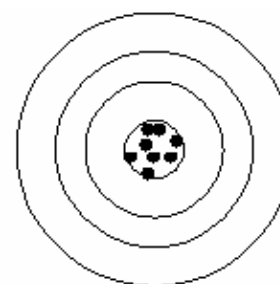

Precise and accurate

(Credit: UNICEF, 2008)

Scientific research studies often explain the level of precision of water quality testing, including statistical analysis that was conducted on the results. Statistical analysis of test results is a complex subject and falls outside the scope of this Manual. This section only presents a simplified discussion of the most important aspects of quality assurance and control.

When you carry out repeated tests many times on the same sample of water, it will rarely happen that you get the same results each time. Measurements and observations are always subject to some error. These errors can be caused by people, equipment, supplies, test methods and environmental conditions (e.g., humidity, light).

Regardless if you are doing field or laboratory testing, a QA/QC system should be designed in the planning stage to help reduce errors. Your system will be simpler for field testing, but it should have a basic set of procedures necessary to remove or reduce errors.

A quality assurance system documents all water quality testing procedures to help ensure reliable results. In general a quality assurance system should include the following elements:

- Management – staff organization, job descriptions and responsibilities
- Standard Operating Procedures – documents describing in detail all procedures for water quality testing, including sampling, transportation, analysis, use of equipment, quality control, calibration and report writing
- Training – for anyone taking water samples or conducting tests (e.g., Community Health Promoters, Water Quality Technicians)
- Equipment – maintenance and calibration
- Record keeping – sampling records and test results
- Clear reporting of results

A quality control system helps to find and eliminate causes of quality problems by checking products and equipment. The following checklist and sections provide further information about how to ensure the quality and reliability of your test results.

Checklist for Ensuring Quality Control

Items	Checks
Calculation and records	<ul style="list-style-type: none"> • Check math calculations for mistakes • Confirm that results have been recorded in the proper units and that any transfer of data from one record to another has been made correctly
Standard solutions	<ul style="list-style-type: none"> • Check the standard solutions that are used for calibrating equipment (old solutions may have deteriorated and errors may occur) • Check on storage conditions, the age of solutions and their expected shelf-life
Reagents	<ul style="list-style-type: none"> • Check whether old reagents have deteriorated • Check fresh reagents to ensure that they have been properly prepared • Check the storage conditions of reagents, especially those that must be stored away from the light or at a high temperature • Check the expiry date of reagents and discard any that are outdated or have been improperly stored
Equipment	<ul style="list-style-type: none"> • Check calibration records and maintenance records for all equipment • Check and recalibrate equipment such as scales, incubators and digital meters • Check that equipment is being properly used

(Adapted from UNEP/WHO, 1996)

The following sections describe more specific actions that you can do to help ensure quality control and reliable test results.

4.5.1 Selecting Equipment and Products

There are several different types of equipment and products available in the commercial market for water quality testing (see Appendix 2: Product Sheets). All have their own advantages and limitations. Some are easy to operate, but may lack in precision. Others are accurate, but may be difficult to read. Similarly some are unable to measure a small quantity of your water sample. Therefore, selecting the appropriate equipment and products is important to meet your testing objectives.

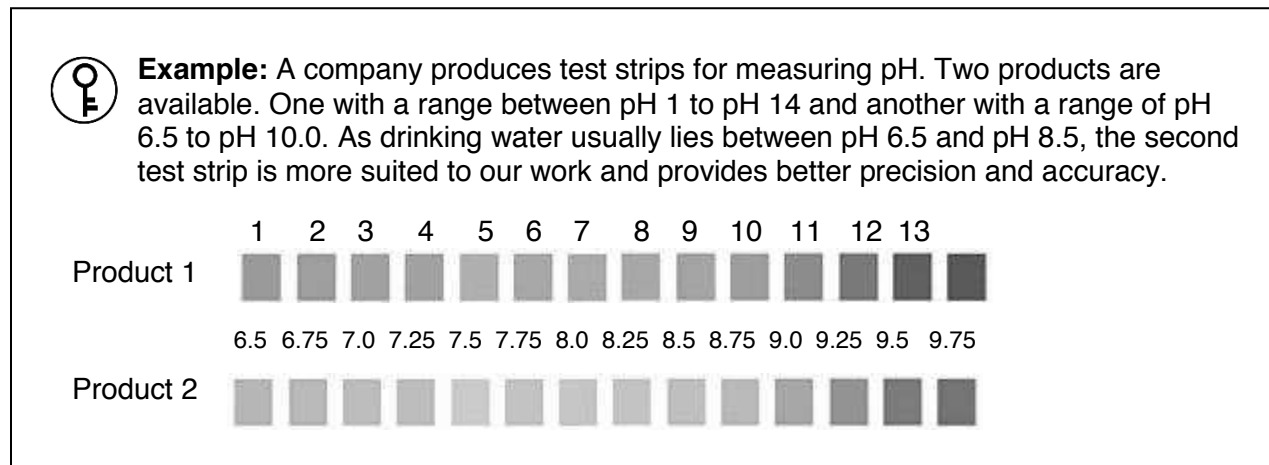

4.5.2 Equipment Calibration

It is important to calibrate equipment according to the manufacturer's specifications to get good results. Most electronic equipment will require some sort of calibration. Commonly used water quality testing equipment that requires calibration include incubators, pH meters, turbidimeters, colorimeters and photometers. Manufacturers should give the instructions for calibration when you buy a piece of equipment.

4.5.3 Quality of Products

Most consumable products have a shelf life and should be used before they expire. Some need to be stored in a refrigerator, while others need to be kept in a cool and dry place. You should follow the manufacturer's instructions help to protect the life of the products and their effectiveness.

The reliability of the reagents and culture media used for microbiological testing is especially important. Large projects should monitor the quality of reagents and culture media on a regular basis. Whenever you need to order new products, it is a good idea to compare them with those currently in use. You may also want to test them with a known level of contamination to see if you get valid results.

You should also check the following prior to using reagents and culture media:

- Expiry date
- Date manufactured
- Condition upon delivery
- Manufacturer's instructions for storage and use

4.5.4 Unequal Distribution of Microorganisms in a Water Sample

One factor that can significantly affect microbiological test results is the uneven distribution of microorganisms in a water source and even within a water sample. This happens because microorganisms like to clump together and may also stick to the sides of your sample container.

It is not uncommon for independent tests performed from a single water sample, and using the same test method, to produce slightly different results. Test results are most variable when microorganisms are present in very low concentrations (BCCDC, 2006).



Note: Thoroughly shake any water sample for at least 10 seconds before testing to help ensure an even distribution of microorganisms throughout the water.

4.5.5 Secondary Contamination

Water samples need to be handled carefully to avoid secondary contamination. This is especially important for microbiological testing since unwanted microorganisms from your hair and skin, as well as from unclean work surfaces and equipment, can contaminate your water samples if you are not careful. Using aseptic techniques helps to prevent contact with microorganisms and eliminates secondary contamination. As well, using aseptic techniques helps to protect the environment and people who doing the testing, ensures valid test results, and can save time and resources by not having to repeat any tests.

Basic sanitary methods to use when working with microorganisms include the following:

Personal Preparation (avoid contamination from bacteria on skin, hair & personal items)

- Tie back long hair
- Wash hands with soap and water and/or use hand sanitizer
- Cover cuts with waterproof plasters (i.e., band aids); alternatively plastic gloves can be used
- Secure loose clothing and jewelry (e.g., neckties, flowing sleeves, long necklaces)
- Wear personal protective equipment such as a lab coat and eye protection if possible
- Roll down sleeves and button up lab coat to protect normal clothes from accidental spills

Preparation of Work Space (avoid contamination from work surfaces and equipment)

- Choose a smooth, non-absorbent work bench for microbiological testing to prevent contamination if there is a spill
- If necessary, cover the work bench with heavy plastic
- Disinfect the work bench with commercial disinfectant (e.g., Dettol or Lysol) or alcohol (e.g., ethanol or isopropyl alcohol) before setting up
- Place testing implements (e.g., pipettes, forceps, media bottles, testing equipment) on clean paper towels and replace when spillage occurs
- Clean and sterilize testing equipment and sample containers (see instructions below)
- Minimize air flow in the testing area by not using fans and open windows since many contaminants are spread by dust particles that land on sterile surfaces

Sanitary Methods for Microbiological Testing (avoid contamination from careless handling and poor technique)

- Do not touch the membrane filter equipment, such as the bronze disc and the collar (see Section 7: Testing for Microbiological Parameters)
- Do not touch the inside of sample containers, Petri dishes, lids or caps
- Do not have food or drinks in the testing area
- Do not leave Petri dishes open when they are not being used
- Sterilize forceps between uses by using a flame (see instructions below)
- Cover your nose and mouth when sneezing
- Test least contaminated samples first (e.g., test filtered water first, then storage water, and source water last)
- Test blank samples to detect secondary contamination (see Section 4.5.7 Controls: Blank Samples and True Positives) (1 for every 10-20 samples)
- Do not use fingers or objects to aid in bacterial colony counting (especially objects that are used for other purposes like pens)
- Clean up workspace before moving to a different task
- Properly dispose of waste (See Section 7: Testing for Microbiological Parameters)
- Disinfect work space when work is complete
- Clean and disinfect equipment before storing
- Store testing equipment in a clean and secure place

All reusable equipment must be cleaned and sterilized thoroughly before each use to avoid secondary contamination and ensure good results. Manufacturers usually include instructions on how to sterilize their equipment. Some methods for sterilizing equipment are:

- **Flaming:** The flame from a cigarette lighter, for example, can be used to sterilize forceps used for holding filter paper. It must be a butane or propane gas lighter, not matches or a lighter that uses gasoline or similar liquid fuel, which would blacken the forceps and leave a residue.

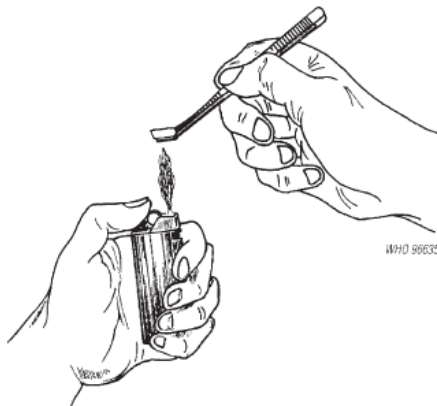

Sterilizing forceps using a cigarette lighter (WHO, 2007)

- **Formaldehyde:** This gas is a powerful bactericide. It is generated by the combustion of methanol (but no other alcohol) in a closed space where oxygen becomes depleted. In the field, this is a convenient way to disinfect the membrane filtration equipment between uses. Manufacturers usually include instructions on how to sterilize their membrane filtration equipment using this method.
- **Conventional oven:** Heat at 180°C for 30 minutes (WHO, 2012)
- **Boiling:** Boil for 10 minutes (CDC, 2010 and WHO, 2012)
- **Autoclave:** Heat at 121°C for 20 minutes (WHO, 1997)
- **Pressure cooker:** Heat for at least 30 minutes (WHO, 1997)

Never use bleach, chlorine or disinfectants on equipment that may leave a residue without properly rinsing (with distilled water) or boiling the equipment afterwards. The residue may affect your results by inhibiting or killing the bacteria you are trying to test for.

4.5.6 Duplicate Samples

Duplicate samples are independent samples taken from the same location at approximately the same time. There is normal variability in the microbiological concentration between one sample and the next from the same water source. By taking duplicate samples, you can check the reliability of your testing procedures and average two samples to get more accurate results.

Ideally, all water samples should be duplicated, but this can be expensive and is not feasible for most projects. Depending on your resources, you should try to duplicate at least 10% of your samples (CDC, 2010).

Example of duplicate sampling at 10%

A rate of 10% duplicate samples means you need to duplicate every 1 in 10 samples. So if you plan to test 50 samples of water, you will need to take a duplicate sample of sample number 10, 20, 30, 40 and 50. So you will end up with 5 more samples to test. It is important that you collect the duplicate in a different container as this will help identify possible errors in sample collection.

4.5.7 Controls: Blank Samples and True Positives

Blank samples help with quality control to make sure that there is no secondary contamination. You test the blank the same as your field samples, but using clear boiled water instead for microbiological testing and deionized or distilled water for physical or chemical testing. If the blank sample shows any results from the test, then you know that there was secondary contamination some time during your sampling and testing procedure. One blank sample should be with completed for every 10-20 samples (CDC, 2010).

A true positive sample is the opposite of a blank sample. You use (or create) a sample which you are certain has fecal contamination. A long stick in a pit latrine or any other method should help you create the sample (1 gram of feces contains over billions of coliform bacteria). Be careful not to cross-contaminate your other samples with this highly contaminated sample. Make sure to filter this sample last. If no growth occurs in this sample, then there may be a problem with your culture media or incubator.

4.6 Health and Safety

It is important to work safely and avoid injuries while carrying out water quality testing. Water quality testing staff may come across a range of hazards in the course of their work. For example, water sources may be highly contaminated with feces or chemicals, access to sampling stations may involve crossing dangerous terrain, and wading in streams carries the possibility of slipping. Field staff should be trained to recognize and deal with as many as possible of the hazards they are likely to encounter (UNEP/WHO, 1996).

It is the responsibility of the project implementer to provide training to anyone involved in water sampling and testing. As a minimum, training should include water safety and first aid. In addition, project staff should understand any special hazards and risks associated with handling specific chemicals (such as arsenic and methanol) and follow the safety precautions.

It is also the responsibility of the project implementer to provide safety equipment, but it is the responsibility of each individual to use the equipment properly and to request equipment if it is not available. Safety equipment such as fire extinguishers, safety glasses, gloves and first aid kits should be suitably located and readily available. Safety equipment should be routinely checked and all staff should be trained in their use. It is also important to make sure that everyone knows who to call in an emergency.



Make sure everyone knows where the FIRST AID KIT is located. At the very least, the kit should contain bandages, gauze and disinfectants.

During water sampling, a basic first aid kit should be carried at all times and should not be left in the transport vehicle if staff need to move far away from it. Where there is a risk of infection from contact with water (as in the case of schistosomiasis, for example), suitable protective clothing, such as rubber gloves, should be provided and used by staff (UNEP/WHO, 1996).



Samples and any waste generated during testing may contain pathogens or chemicals that may be harmful to health and must be properly and safely disposed. See Sections 6 and 7 for more information on how to dispose of waste specifically from chemical and microbiological testing.

Make sure everyone knows WHO TO CALL in an emergency.

4.7 Summary of Key Information

- The goal of water sampling is to collect the sample under normal, everyday conditions in order to gain a representative sample of the water source.
- Many project implementers are concerned about the effectiveness of a HWT technology and want to make sure that it is effectively removing pathogens from drinking water. It is only worthwhile to carry out water quality testing if the technology is being operated and maintained properly. Samples should not be taken from any HWT technology which is not fulfilling the normal operating conditions.
- The numbers of bacteria within a water sample rapidly decline 24 hours after it has been collected. Samples should be collected and placed on ice in an insulated container if they cannot be analyzed immediately. Samples should be analyzed the same day and refrigerated overnight if necessary. Samples exceeding 24 hours holding time (from collection to testing) should not be tested.
- There is an inherent variability associated with all analytical techniques. Therefore, the result of a water quality test is only a best estimate or approximation of the true value of being measured.
- Regardless if you are conducting portable or laboratory testing, a quality assurance and quality control system should be designed to help reduce errors.
- It is not uncommon for independent tests performed from a single water sample, and using the same test method, to produce slightly different results. Test results are most variable when microorganisms are present in very low concentrations.
- It is the responsibility of the project implementer to provide safety equipment and training to anyone involved in water sampling and testing.

4.8 References

BCCDC Environmental Health Laboratory Services (2006). Safe Drinking Water: Public Health Laboratory Surveillance Update. British Columbia, Canada. Available at: www.vch.ca/environmental/docs/water/safe_drinking_water.pdf

Centers for Disease Control and Prevention (2010). Microbiological Indicator Testing in Developing Countries: A Fact Sheet for the Field Practitioner. Available at: <http://sanitationupdates.files.wordpress.com/2010/11/microbiology2020.pdf>

DACAAR (2013). Personal communication on how to take a water sample from a hand pump. Kabul, Afghanistan.

United Nations Environment Programme and the World Health Organization (1996). Water Quality Monitoring - A Practical Guide to the Design and Implementation of Freshwater Quality Studies and Monitoring Programmes. EF&N Spon, an imprint of Chapman & Hall, London, UK.

World Health Organization (1997). Guidelines for Drinking Water Quality, Second Edition, Volume 3, Surveillance and Control of Community Supplies. WHO, Geneva, Switzerland. Available at: www.who.int/water_sanitation_health/dwq/gdwq2v1/en/index2.html

World Health Organization (2012). Rapid Assessment of Drinking-Water Quality: A Handbook for Implementation. WHO, Geneva, Switzerland. Available at: www.who.int/water_sanitation_health/publications/2012/rapid_assessment/en/index.html

Introduction to Drinking Water Quality Testing

Section 5: Testing for Physical Parameters

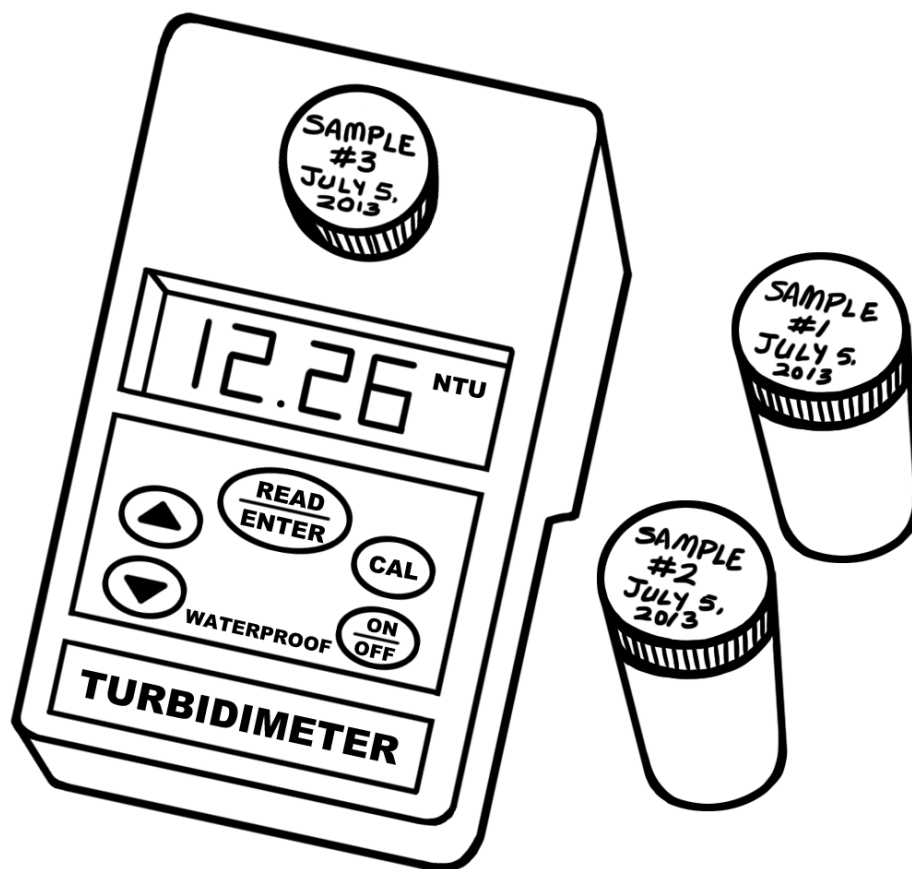

Table of Contents

Section 5: Testing for Physical Parameters	i
5.1 Introduction	1
5.2 WHO Guidelines for Physical Parameters	1
5.3 Potential Health Effects.....	1
5.4 Colour	1
5.5 Taste and Odour.....	2
5.6 Temperature	3
5.7 Turbidity.....	3
5.7.1 Simple Estimate	4
5.7.2 Turbidity Tube	4
5.7.3 Digital Turbidimeter.....	5
5.8 Summary of Key Information	6
5.9 References	6

5.1 Introduction

The physical parameters of drinking water are usually things that we can measure with our senses: colour, taste, odour and temperature and turbidity. In general, we judge drinking water to have good physical qualities if it is clear, tastes good, has no smell and is cool.

5.2 WHO Guidelines for Physical Parameters

The table below shows the World Health Organization (WHO) Guidelines for Drinking Water Quality for physical parameters. Guideline values have not been established for those parameters, such as colour, odour and temperature, which have no direct link to adverse health impacts.

WHO Guidelines for Drinking Water Quality: Physical Parameters

Parameter	WHO Guideline
Colour	Aesthetic only, no health based value is proposed
Odour	Aesthetic only, no health based value is proposed
Temperature	Aesthetic only, no health based value is proposed
Turbidity	< 1 NTU and preferably much lower for effective disinfection; < 5 NTU for small water supplies

(WHO, 2011)

5.3 Potential Health Effects

Physical parameters do have not direct health effects. However, the physical characteristics of drinking water may indicate a higher risk of microbiological and chemical contamination which may be harmful to human health. For example, increased turbidity levels are often associated with higher levels of pathogens such as viruses, protozoa and bacteria in water (WHO, 2011).

As well, it is natural for people to suspect the quality of drinking water that looks dirty or has an unpleasant taste or smell, even though these characteristics do not cause direct health effects. Safe water that does not taste, look or smell good could lead people to reject the water and use other sources that are less safe (WHO, 2011).

5.4 Colour

The colour of a water sample is usually evaluated by simple visual observation. It can also be measured by visual comparison with a series of standard solutions. Levels of colour above 15 True Colour Units (TCU) can be detected in a glass of water by most people, although it does not pose a health threat.

Colour may occur in drinking water for different reasons, such as from the presence of:

- Natural organic matter and vegetation, such as leaves and bark
- Metals such as iron, manganese and copper, which are abundant in nature and are naturally coloured (see Section 6 for more information about chemical testing)
- Highly coloured industrial waste, the most common are pulp, paper and textile waste

Colour Observations

Observations	Possible Contaminants
Foamy	Detergents
Black	Manganese, bacteria growth
Brown, yellow or red	Iron
Dark brown or yellow	Tannins and pigment from vegetation
White deposits or scale	Hardness, dissolved metals

The colour of surface water is mainly caused by natural organic matter. In general, hard surface water is less coloured than soft surface water. The colour of groundwater is usually due to the presence of metals, such as iron, manganese and copper. In some areas, especially those associated with limestone, the colour of groundwater from both shallow and deep wells may be from natural organic matter (Health Canada, 1995).

The presence of colour in water may have an effect on the measurement of turbidity. As well, moderate colour in certain types of water may have an adverse effect upon removing turbidity by coagulation and sedimentation treatment methods (Health Canada, 1995). Water that is coloured with organic matter can also reduce the effectiveness of chlorine disinfection and make it difficult to produce free residual chlorine (FRC).

5.5 Taste and Odour

Although taste and odour do not pose a direct health threat, they may indicate chemical or biological contamination, especially when a change happens quickly. Poor taste or odour may suggest the need for more water quality testing.

Taste and odour are perhaps the most important characteristics of drinking water from the point of view of the user. It is next to impossible to convince people that water is safe to drink if it tastes or smells bad. Safe water that does not taste, look or smell good could lead people to reject the water and use other sources that are less safe (WHO, 2011).

A common example is chlorine. People often dislike the taste and smell of over-chlorinated water (in the context of a new water supply or household chlorination project), and will prefer to drink a different, and possibly contaminated, water source instead. Guidance in proper chlorine dosage and awareness raising should always be done whenever people are using chlorinated water.

Odour Observations and Possible Contaminants

Odour Observations	Possible Contaminants
Earthy, musty, moldy	<ul style="list-style-type: none"> • Most frequently observed • May be detected only after addition of chlorine • Can be produced by specific bacteria called actinomycetes • Very low concentrations can lead to complaints
Grass, hay, straw, wood	<ul style="list-style-type: none"> • Often associated with algal by-products and sometimes described as decayed vegetation
Marshy, swampy, septic, sewage, rotten egg	<ul style="list-style-type: none"> • Very offensive • Sulphur that is natural or human made
Chlorine	<ul style="list-style-type: none"> • Chlorine residual after disinfection

In general, odour and taste are evaluated by simple observation. When smelling a water sample from an unknown source, do not breathe in the odour directly. Use your hand to gently waft the vapours towards your nose. Never drink a water sample from an unknown source.

5.6 Temperature

Temperature does not carry any significance in terms of contaminaton. However, we generally prefer cool water over warm water. High water temperature (20-30°C) can also increase the growth of microorganisms and may lead to taste, odour, colour and corrosion problems. The most desirable temperature for drinking water is between 4°C and 10°C (39-50°F). Temperatures above 25°C (77°F) are usually objectionable.

A digital or regular thermometer can be used to measure the temperature of water.

5.7 Turbidity

Turbidity is caused by suspended solids, such as sand, silt and clay, floating in water. Light reflects off these particles, which makes the water look cloudy or dirty.

Turbidity is measured in nephelometric turbidity units (NTU) or Formazin turbidity units (FTU), depending on the method and equipment used. Turbidity measured in NTU uses nephelometric methods (commonly used in portable test kits) that depend on passing specific light of a specific wavelength through the sample. FTU is considered comparable in value to NTU and is the unit of measurement when using absorptometric methods that are more commonly used in a laboratory (Wilde, 2005). The higher the turbidity, the harder it is to see through the water and the higher the NTU and FTU measurement. Turbidity can be noticed by the naked eye above approximately 4 NTU (WHO, 2011).

Turbidity itself will not make you sick; however, higher turbidity levels are often associated with higher levels of microorganisms (i.e., bacteria, viruses, protozoa) because they attach themselves to the particles in the water. Therefore, we must be cautious of turbid water as it usually has more pathogens, so drinking it increases our chances of becoming sick.

Relationship Between Turbidity and Presence of *E. coli* in Water

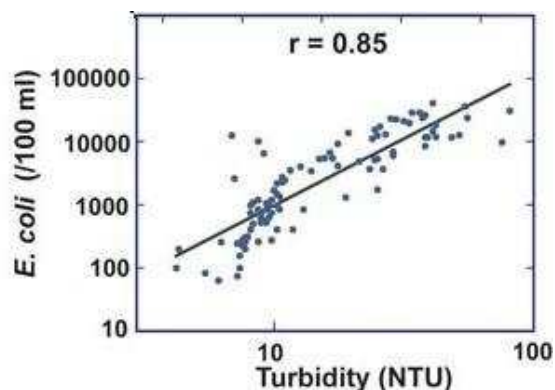

The WHO recommends that turbidity should be no more than 1 NTU, and preferably much lower, to ensure proper disinfection. Large, well-run municipal supplies should be able to achieve less than 0.5 NTU before disinfection at all times and should be able to average 0.2 NTU or less. Small community water systems and household water treatment methods may not be able to achieve such low levels of turbidity. In these cases, the aim should be to produce water that has turbidity of less than 5 NTU and, if at all possible, below 1 NTU (WHO, 2011).

There are three ways to measure turbidity: 1) simple estimate, 2) quantitative estimate using a turbidity tube or 3) using a digital turbidimeter.

5.7.1 Simple Estimate

A simple test to measure the turbidity is to use a 2 L clear plastic bottle filled with the sample water. Place this on top of large print such as the CAWST logo on this manual. If you can see this logo looking down through the top of the bottle, the water probably has a turbidity of less than 50 NTU.



5.7.2 Turbidity Tube

A turbidity tube is another easy and inexpensive way to visually estimate NTU. It is practical for field testing since it is very portable and does not need batteries or replacement parts. A limitation is that it is harder to read levels less than 10 NTU with a turbidity tube.

A turbidity tube can be easily understood because it is a visual test. It can pass on more information about what is being measured than looking at a digital reading on a screen. This gives an opportunity to educate community members about water quality issues, such as source protection and treatment options.

Most portable test kits provide a turbidity tube as part of the kit. You can also order them separately from commercial manufacturers. See Product Sheets in Appendix 2.

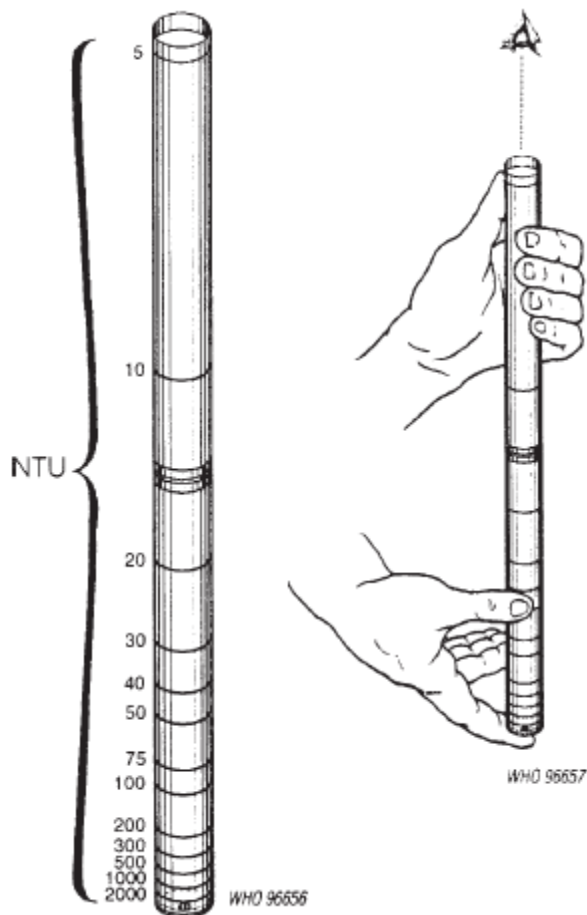

How to read NTU using a turbidity tube
(Credit: WHO, 1997)

How to Use a Turbidity Tube

1. Slowly pour some water into the tube.
2. Place your head 10 to 20 centimeters directly over the tube so that you can see the disc at the bottom of the tube.
2. Keep adding water until the pattern on the disc at the bottom becomes hard to see when you look down the tube.
3. Stop pouring as soon as the pattern on the disk can no longer be seen.
4. Read the turbidity level in NTUs from the scale on the side of the tube.

5.7.3 Digital Turbidimeter

A turbidimeter is operated by a battery or power supply and it gives the digital reading of the turbidity level. A turbidimeter gives more accurate results, although it is more expensive and vulnerable to damage. It has the capacity to measure a wide range of turbidity levels and is useful to measure water which has a turbidity level less than 10 NTU. There are also different types of turbidimeters that you can buy from commercial manufacturers. See Product Sheets in Appendix 2.

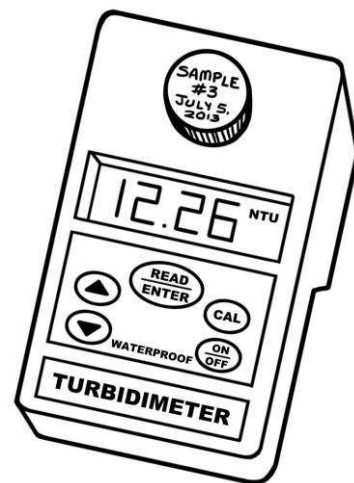

5.8 Summary of Key Information

- The physical parameters of drinking water are usually things that we can measure with our senses: colour, taste, odour, temperature and turbidity.
- In general, we judge drinking water to have good physical qualities if it is clear, tastes good, has no smell and is cool.
- Physical parameters do have not direct health effects. However, the presence of physical contaminants may indicate a higher risk of microbiological and chemical contamination which may be harmful to human health.
- Taste and odour are perhaps the most important characteristics of drinking water from the point of view of the user. It is next to impossible to convince people that water is safe to drink if it tastes or smells bad. Safe water that does not taste, look or smell good could lead people to reject the water and use other sources that are less safe.
- Turbidity is caused by suspended solids, such as sand, silt and clay, floating in water. Light reflects off these particles, which makes the water look cloudy or dirty. Turbidity is measured in nephelometric turbidity units (NTU) or Formazin turbidity units (FTU).
- Turbidity will not make you sick; however, higher turbidity levels are often associated with higher levels of microorganisms (i.e., bacteria, viruses, protozoa) because they attach themselves to the particles in the water. Therefore, we must be cautious of turbid water as it usually has more pathogens, so drinking it increases our chances of becoming sick.
- There are three ways to measure turbidity: 1) simple estimate, 2) quantitative estimate using a turbidity tube or 3) using a digital turbidimeter.

5.9 References

Health Canada (1995). Colour, Environmental and Workplace Health. Available at: www.hc-sc.gc.ca/ewh-semt/pubs/water-eau/colour-couleur/index_e.html

Wilde, F.D., ed. (2005). Field Measurements: U.S. Geological Survey Techniques of Water-Resources Investigations, Book 9, Chap. A6. Available at: <http://water.usgs.gov/owq/FieldManual/>

World Health Organization (1997). Guidelines for Drinking Water Quality, Second Edition, Volume 3, Surveillance and Control of Community Supplies. WHO, Geneva, Switzerland. Available at: www.who.int/water_sanitation_health/dwq/gdwq2v1/en/index2.html

World Health Organization (2011). Guidelines for Drinking-Water Quality, Fourth Edition. WHO, Geneva, Switzerland. Available at: www.who.int/water_sanitation_health/dwq/secondaddendum20081119.pdf

Introduction to Drinking Water Quality Testing

Section 6: Testing for Chemical Parameters

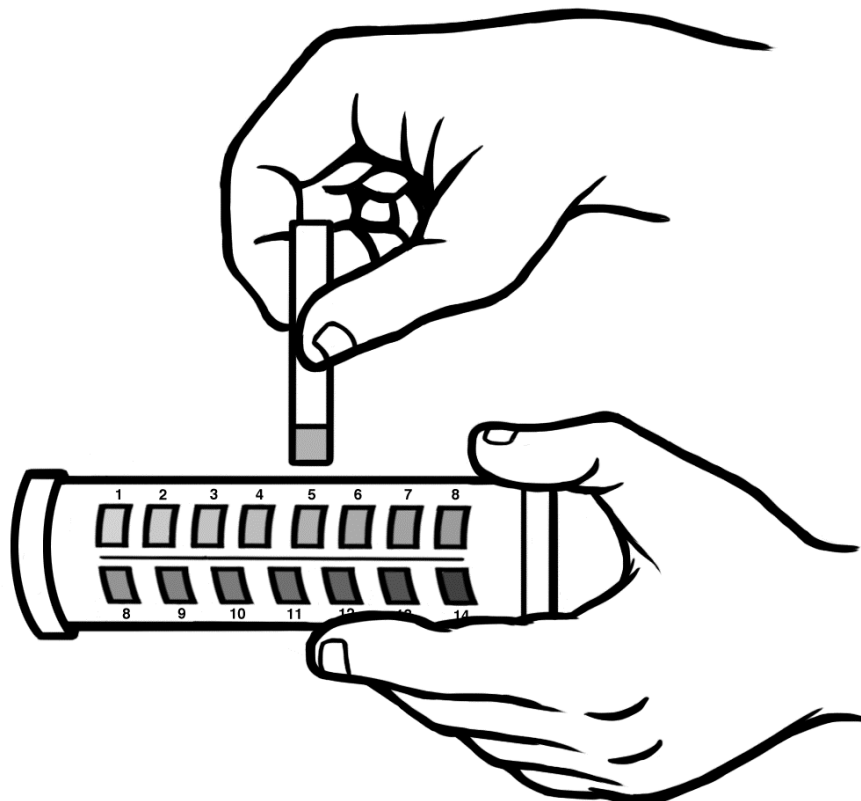



424 Aviation Road NE
 Calgary, Alberta, T2E 8H6, Canada
 Phone: + 1 (403) 243-3285, Fax: + 1 (403) 243-6199
 E-mail: resources@kawst.org, Website: www.kawst.org

CAWST, the Centre for Affordable Water and Sanitation Technology, is a nonprofit organization that provides training and consulting to organizations working directly with populations in developing countries who lack access to clean water and basic sanitation.

One of CAWST's core strategies is to make knowledge about water common knowledge. This is achieved, in part, by developing and freely distributing education materials with the intent of increasing the availability of information to those who need it most.

This document is open content and licensed under the Creative Commons Attribution Works 3.0 Unported License. To view a copy of this license, visit <http://creativecommons.org/licenses/by/3.0> or send a letter to Creative Commons, 171 Second Street, Suite 300, San Francisco, California 94105, USA.



You are free to:

- Share – to copy, distribute and transmit this document
- Remix – to adapt this document



Under the following conditions:

- Attribution. You must give credit to CAWST as the original source of the document. Please include our website: www.kawst.org

CAWST will produce updated versions of this document periodically. For this reason, we do not recommend hosting this document to download from your website.



Stay up-to-date and get support:

- Latest updates to this document
- Other workshop & training related resources
- Support on using this document in your work

CAWST provides mentorship and coaching on the use of its education and training resources.

www.kawst.org/resources

CAWST and its directors, employees, contractors and volunteers do not assume any responsibility for and make no warranty with respect to the results that may be obtained from the use of the information provided.



Table of Contents

Section 6: Testing for Chemical Parameters	i
6.1 Introduction	1
6.2 Priority Chemical Parameters	1
6.3 WHO Guidelines for Chemical Parameters.....	2
6.4 Test Methods	3
6.4.1 Laboratory Test Methods	4
6.4.2 Portable Test Methods.....	5
6.5 Safe Waste Disposal.....	8
6.6 Summary of Key Information	9
6.7 References	10

6.1 Introduction

Water may contain chemicals which can be beneficial or harmful to our health. Many chemicals find their way into our drinking water supply through different natural processes and human activities. Naturally occurring chemicals, such as arsenic, fluoride, iron and manganese, are generally found in groundwater. Human activities can add other chemicals to our water supplies, such as nitrogen and pesticides. Many developing countries are experiencing a rise in industrial activity with no strict compliance to environmental rules and regulations. As a result, water sources are increasingly becoming contaminated with industrial chemical waste.

6.2 Priority Chemical Parameters

Unlike microbiological contamination, most chemicals in drinking water pose a health concern only after years of exposure. Often chemical contamination goes unnoticed until disease occurs due to chronic exposure. The severity of health effects depends upon the chemical and its concentration, as well as the length of exposure. There are only a few chemicals that can lead to health problems after short-term exposure, such as nitrate, unless there is a massive contamination of a drinking water supply (WHO, 2011).

It is not possible to test water for all of the chemicals that could cause health problems, nor is it necessary. Most chemicals occur rarely, and many result from human contamination of a small area, affecting only a few water sources.

However, three chemicals have the potential to cause serious health problems and occur over widespread areas. These are arsenic and fluoride, which can occur naturally, and nitrate, which is commonly used in fertilizer for agriculture. These three contaminants are more often found in groundwater, though surface water can also be impacted. When planning new water supply projects, especially using groundwater resources, these three contaminants should be prioritized for testing (UNICEF, 2008).

A second priority for water quality testing should be for chemical parameters that commonly cause water to be rejected for aesthetic purposes, such as metals (mainly iron and manganese) and total dissolved solids (salinity) (UNICEF, 2008).

When water is disinfected with chlorine, it is also important to monitor the drinking water quality for pH and free residual chlorine (FRC) as indicators of appropriate and effective treatment. As well, it may be important to test for chemicals that are known to be present locally, such as mercury or lead from industrial pollution.

These priority chemical parameters are discussed in more detail in the Chemical Fact Sheets found in Appendix 3.

6.3 WHO Guidelines for Chemical Parameters

“Pure” water does not actually exist in nature, as all water contains some naturally occurring chemicals that have leached from the surrounding environment. In most cases, the levels of naturally occurring chemicals are either beneficial, or minimal and of little concern. There are also many human made chemicals that can contaminate water and affect its usability. The World Health Organization (WHO) divides the sources of chemicals into the following five groups.

Sources of Chemical Contamination

Source of Chemicals	Examples	Common Chemicals
Naturally occurring	Rocks and soils	Arsenic, chromium, fluoride, iron, manganese, sodium, sulfate, uranium
Agricultural activities	Manure, fertilizer, intensive animal practices, pesticides	Ammonia, nitrate, nitrite
Industrial sources and human dwellings	Mining, manufacturing and processing industries, sewage solid waste, urban runoff, fuel leakages	Nitrate, ammonia, cadmium, cyanide, copper, lead, nickel, mercury
Water treatment	Water treatment chemicals, piping materials	Aluminium, chlorine, iodine, silver
Pesticides used in water for public health	Larvicides used to control insect vectors of disease	Organophosphorus compounds (e.g., chlorpyrifos, diazinon, malathion) and carbamates (e.g., aldicarb, carbaryl, carbofuran, oxamyl)

(Adapted from WHO, 2011)

The 2011 WHO Guidelines for Drinking Water Quality recommend the maximum chemical concentrations based on research and experiments. A guideline value represents the concentration of a chemical that does not result in any significant risk to health over a lifetime of consumption.

For most kinds of chemicals, it is believed that there is a dose below which no adverse effect will occur. The WHO Guidelines are determined based on the tolerable daily intake (TDI) of a chemical. The TDI is an estimate of the amount of a chemical in food and drinking water, expressed on a body weight basis (milligram or microgram per kilogram of body weight), that can be ingested over a lifetime without significant health risk, and with a margin of safety (WHO, 2011).

The WHO Guidelines do not include some chemicals such as iron, calcium, sodium, magnesium and zinc. This is because these chemicals pose no health risk at the levels generally found in drinking water.

Appendix 4 summarizes the WHO Guidelines for chemicals in drinking water and the potential health effects.

6.4 Test Methods

There are several factors to be taken into consideration when choosing an appropriate test method for different chemical parameters, including:

- Available resources
- Required level of accuracy and precision
- Technical skills of staff
- Geographical location
- Objective of the results

Laboratory and field testing are the two main test methods used by government and nongovernmental organizations (NGOs). NGOs tend to use portable kits for their chemical testing, whereas governmental institutes, research centres and universities generally prefer to use laboratory testing which can provide more accurate results. The following table lists possible test methods for some chemical parameters.

Test Methods for Some Chemical Parameters

Chemical	Possible Test Methods
Aluminum	Test strips, colour disc comparator, photometer, laboratory
Arsenic	Laboratory, portable test kit using the Gutzeit method
Cadmium	Photometer, laboratory
Chlorine (free)	Test strips, pool test kit, colour disc comparator, photometer
Chromium	Laboratory
Copper	Test strips, colour disc comparator, photometer, laboratory
Cyanide	Laboratory
Fluoride	Colour disc comparator, photometer, laboratory
Iron	Test strips, colour disc comparator, photometer, laboratory
Lead	Laboratory
Manganese	Test strips, colour disc comparator, photometer, laboratory
Mercury	Laboratory
pH	Test strips, digital pH meter, laboratory
Nitrate	Test strips, colour disc comparator, photometer, laboratory
Nitrite	Test strips, colour disc comparator, photometer, laboratory
Selenium	Laboratory
TDS	Digital electrical conductivity (EC) meter, laboratory

(Adapted from UNICEF, 2010)

6.4.1 Laboratory Test Methods

The following methods, in order of complexity, are generally used to test chemical contaminants in the laboratory. A full review of laboratory methods for measuring the various parameters important to drinking water quality is beyond the scope of this Manual. The WHO Guidelines for Drinking Water Quality provides a comprehensive list of laboratory methods for specific chemicals that have guideline values (WHO, 2011).

Colorimetric Method

Chemical reagents are added to the water sample which react with the particular chemical parameter of interest. The product that is formed absorbs light at a particular wavelength. The water sample is then analyzed in a colorimeter or spectrophotometer and compared to known standards.

Electrode methods

Ion-selective electrodes can measure the concentration of certain ions in the water sample. pH is easily measured with an electrode and meter.

Chromatography

Samples are passed through a column containing a specific packing or coating that selectively retains certain types of chemicals. Different compounds pass through the column at different speeds, depending on their affinity to the packing or coating. A detector at the exit of the column quantifies the concentration of the chemical. There are many types of chromatography: ion chromatography, liquid chromatography and gas chromatography.

Atomic Absorption Spectrometer (AAS)

AAS is used to analyze the presence of metals. Samples are heated either in a flame or electrically in a graphite furnace, and the concentration is determined by the metal atom's absorption of light at a particular wavelength.

Inductively Coupled Plasma (ICP)

ICP is also used to analyze the presence of metals. Samples are broken down to the atomic level and metals are detected either through atomic emission spectroscopy or mass spectroscopy.

Colorimetric and electrode methods can be implemented in basic laboratories with relative ease. Chromatography and AAS are considerably more expensive and complex, and are more appropriate for central or reference laboratories. ICP methods are very costly and difficult, and are uncommon in developing countries (UNICEF, 2008).

6.4.2 Portable Test Methods

Many types of portable test kits are available to measure various chemical parameters in drinking water. These are generally used for checking compliance as well as for operational monitoring of drinking water quality.

Although portable test kits have the advantage of being simple to use in non-laboratory environments and are often available at relatively low prices, their analytical accuracy is generally less than that of the laboratory methods listed above. However, when properly used, portable test kits provide valuable tools for rapidly assessing numerous chemical parameters when commercial laboratories are not available or are too expensive (WHO, 2011).

The most popular portable test methods are test strips, colour comparators, colorimeters and photometers and digital meters. It is necessary to check the validity of the test method before using it.

Test (Reagent) Strips

There are many different types of test strips available to measure different chemical contaminants. They are generally convenient and easy to use, provide quick results, and are the cheapest way to do field testing. Test strips are also available in individual packaging. This can be useful as the strips can deteriorate with humidity, heat, dust and light. The main limitation of test strips is that they are less accurate since they require a visual interpretation of the results.

Test strips typically have a plastic handle with a reagent area at one end. Typically, you dip the reagent area into a water sample, remove it and compare the colour of the reagent area with a colour chart. Some test strips work by presence/absence of a colour change at a maximum concentration.

It is important to use the required activation method for the test strip you are using. Different products require different activation methods, such as:

- Dipping the strip in the sample
- Swishing the strip back and forth in the sample
- Holding the reagent area in a stream of the sample

Also, different test strips require different times that you must wait before you compare the strip to the colour chart. Using the wrong activation method or reading your results too early or late for that test strip may lead to incorrect results.



Sometimes people ignore the instructions for the specific test strip that they are using. This can lead to incorrect results. There are two things to keep in mind: the activation method and the read time. These instructions are given on the bottle label and in the product insert.

Test strips are available to measure pH and a variety of chemicals, such as chlorine and manganese.

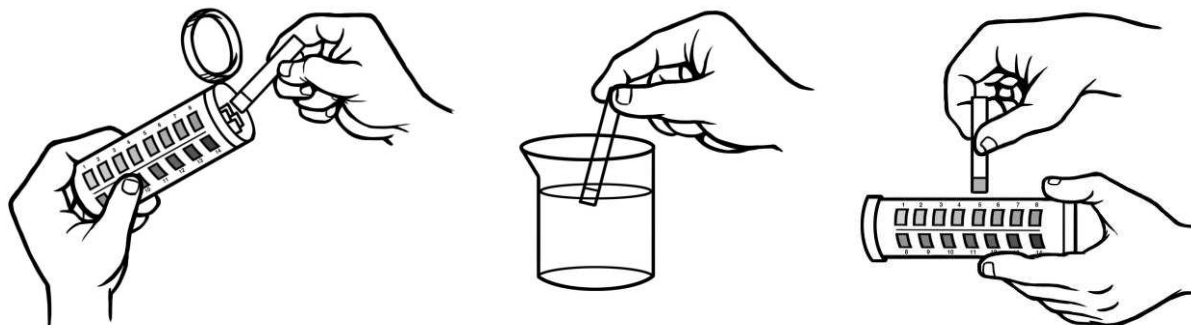

Using a test strip by dipping it into a water sample and checking the colour against a scale to measure the value



Tip: Understanding the limits and concentration ranges of the chemical parameters you are testing is essential when selecting the most appropriate equipment and products. Make sure to purchase the test strip that is most suited to your purpose. Different ranges can exist for the same parameter.

For example, a company produces test strips for measuring pH. Two products are available. One with a range between pH 1 to pH 14 and another with a range of pH 6.5 to pH 10.0. As drinking water usually lies between pH 6.5 and pH 8.5, the second test strip is more suited to our work and provides better precision and accuracy.

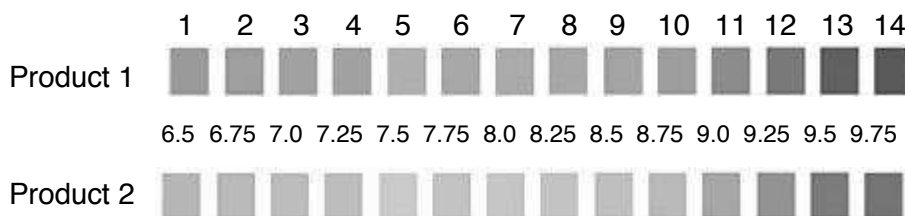

Colour Disc Comparator

There are different types of colour disc comparators that are available. The comparator is used with a range of interchangeable colour discs. These colour discs compare the colour produced for the test against the standard test colours provided on the disc. Colour discs are available for a range of chemical parameters such as chlorine, fluoride, nitrate, iron and manganese. Colour comparators can sometimes be more accurate than test strips and they are easy to use, but they are more expensive, require more materials and still require a visual determination of the chemical concentration.

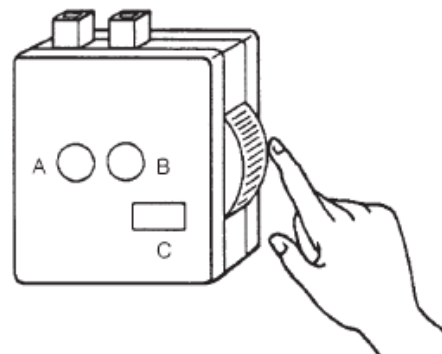

Colour disc comparator (Credit: WHO, 1997)

Colorimeter and Photometer

Colorimeters and photometers are digital instruments that use a light source to measure the chemical concentration in a water sample. Compared to test strips, they offer more accurate and repeatable results since the concentration is given as a digital reading. As well, colorimeters and photometers can read a large variety of chemicals in a water sample, as well as a wider numerical range within each parameter. However, they are more expensive, need a power source and require training to ensure they are being used properly.



Photometer used to measure chemicals in water

Colorimeter Versus Photometer

The terms colorimeter and photometer are sometimes used interchangeably and can cause confusion. Both are digital instruments that measure the amount of coloured light absorbed by a coloured sample in reference to a colourless sample (blank); however, they use different technologies to take the colour measurements. Colorimeters are generally less expensive and more rugged than a photometer; however, they are not as precise and the quality can vary between manufacturers. Photometers are generally used more for research and development.

Digital Meters

Some portable test kits include various digital meters to measure parameters like pH and electrical conductivity (EC). They are relatively easy to use and can provide more accurate measurements than other methods, such as test strips. The main disadvantages are the need to calibrate the meters and replace batteries as required, and the general fragility of electronic equipment.

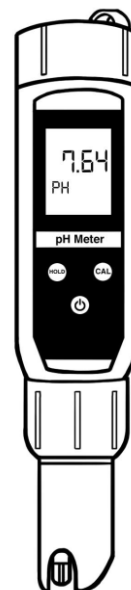

Digital pH meter

Arsenic Test Kits

Testing for arsenic in drinking water, especially at the $\mu\text{g/L}$ level, is difficult. There are no simple test strip or colour disc comparator kits available. Arsenic testing used to be only possible in a laboratory. However, as a result of the discovery of significant arsenic contamination of groundwater in Asia and elsewhere, a variety of portable test kits are now available. All of these rely on the Gutzeit method, which consists of several steps (UNICEF, 2008).

Most commercially available portable test kits typically provide colour reference charts, with reported detection limits around $10 \mu\text{g/L}$. However, evaluations have shown that the results are semi-quantitative at best, especially at lower levels ($<100 \mu\text{g/L}$). The kits are most effectively used in a positive/negative format with a reference value of $50 \mu\text{g/L}$, which is the drinking water standard in many countries affected by arsenic contamination. At this level, most samples containing $50\text{--}99 \mu\text{g/L}$ are identified as positive, and nearly all samples containing $100 \mu\text{g/L}$ or more result in positive test results, though the quantitative result may be incorrect (UNICEF, 2008).

Refer to Appendix 2 for Product Sheets of different arsenic test kits.

6.5 Safe Waste Disposal

Chemical test samples must be disposed of safely and properly. Contaminated sample containers (e.g., sample bottles, test tubes) must be washed before they can be reused. To prepare the containers, they should be washed with soap and rinsed at least three times (five is better) with distilled water to remove any residue. If distilled water is not available, clean chlorine-free water may be used (e.g., filtered and then boiled) (UNEP/WHO, 1996).

Sample containers for physical and chemical tests need to be clean, but not sterilized. However, often the same water sample is used for physical, chemical and microbiological testing, so then the container must be sterilized.

Liquid chemical waste can be flushed down the toilet or sink with plenty of water. Be sure to clean the basin afterwards.

Solid waste, such as test strips, can be burned and/or disposed of in the garbage. Solid waste from arsenic testing should not be burned. It should be disposed using a designated garbage bag. Try to not mix the waste with common municipal waste.

Always wash your hands thoroughly with soap after handling the contaminated waste and before touching clean and sterilized equipment. If possible, you should wear disposable gloves.

6.6 Summary of Key Information

- Sources of chemical contaminants can be divided into the following five groups:
 - Naturally occurring
 - From agricultural activities
 - From industrial sources and human dwellings
 - From water treatment
 - From pesticides used in water to protect public health
- Unlike microbiological contamination, most chemicals in drinking water pose a health concern only after years of exposure. Often chemical contamination goes unnoticed until disease occurs due to chronic exposure.
- The severity of health effects depends upon the chemical and its concentration, as well as the length of exposure.
- It is not possible to test water for all of the chemicals that could cause health problems, nor is it necessary. Most chemicals occur rarely, and many result from human contamination of a small area, affecting only a few water sources.
- Three chemicals have the potential to cause serious health problems and occur over widespread areas: arsenic, fluoride and nitrate. These three contaminants are more often found in groundwater, though surface water can also be impacted. When planning new water supply projects, especially using groundwater resources, these three contaminants should be prioritized for testing (UNICEF, 2008).
- A second priority for water quality testing should be for chemical parameters that commonly cause water to be rejected for aesthetic purposes, such as metals (mainly iron and manganese) and total dissolved solids (salinity) (UNICEF, 2008).
- When water is disinfected with chlorine, it is also important to monitor the drinking water quality for pH and free residual chlorine (FRC) as indicators of appropriate and effective treatment. As well, it may be important to test for chemicals that are known to be present locally, such as mercury or lead from industrial pollution.
- There are several factors to be taken into consideration when choosing an appropriate test method for different chemical parameters, including:
 - Available resources
 - Required level of accuracy and precision
 - Technical skills of staff
 - Geographical location
 - Objective of the results
- Many types of portable test kits are available to measure various chemical parameters in drinking water. These are generally used for checking compliance as well as for operational monitoring of drinking water quality.

- Although portable test kits have the advantage of being simple to use in non-laboratory environments and are often available at relatively low prices, their analytical accuracy is generally less than that of laboratory methods. However, when properly used, portable test kits provide valuable tools for rapidly assessing numerous chemical parameters when commercial laboratories are not available or too expensive (WHO, 2011).
- The most popular portable test methods are test strips, colour comparators, colorimeters and photometers and digital meters.
- Testing for arsenic in drinking water, especially at the $\mu\text{g/L}$ level, is difficult. There are no simple test strip or colour disc comparator kits available. Arsenic testing used to be only possible in a laboratory. However, a variety of portable test kits are now available. All of these rely on the Gutzeit method, which consists of several steps (UNICEF, 2008).

6.7 References

United Nations Environment Programme and the World Health Organization (1996). Water Quality Monitoring - A Practical Guide to the Design and Implementation of Freshwater Quality Studies and Monitoring Programmes. EF&N Spon, an imprint of Chapman & Hall, London, UK.

UNICEF (2008). UNICEF Handbook on Water Quality. UNICEF, New York, USA. Available at: www.unicef.org/wash/files/WQ_Handbook_final_signed_16_April_2008.pdf

UNICEF (2010). Technical Bulletin No.6, Water Quality Assessment and Monitoring. UNICEF, Supply Division, Copenhagen, Denmark. Available at: www.unicef.org/supply/files/Water_Quality_Assessment_Monitoring.pdf

World Health Organization (1997). Guidelines for Drinking Water Quality, Second Edition, Volume 3, Surveillance and Control of Community Supplies. WHO, Geneva, Switzerland. Available at: www.who.int/water_sanitation_health/dwq/gdwq2v1/en/index2.html

World Health Organization (2011). Guidelines for Drinking-Water Quality, Fourth Edition. WHO, Geneva, Switzerland. Available at: www.who.int/water_sanitation_health/dwq/secondaddendum20081119.pdf

World Health Organization (2012). Rapid Assessment of Drinking-Water Quality: A Handbook for Implementation. WHO, Geneva, Switzerland. Available at: www.who.int/water_sanitation_health/publications/2012/rapid_assessment/en/index.html

Introduction to Drinking Water Quality Testing

Section 7: Testing for Microbiological Parameters

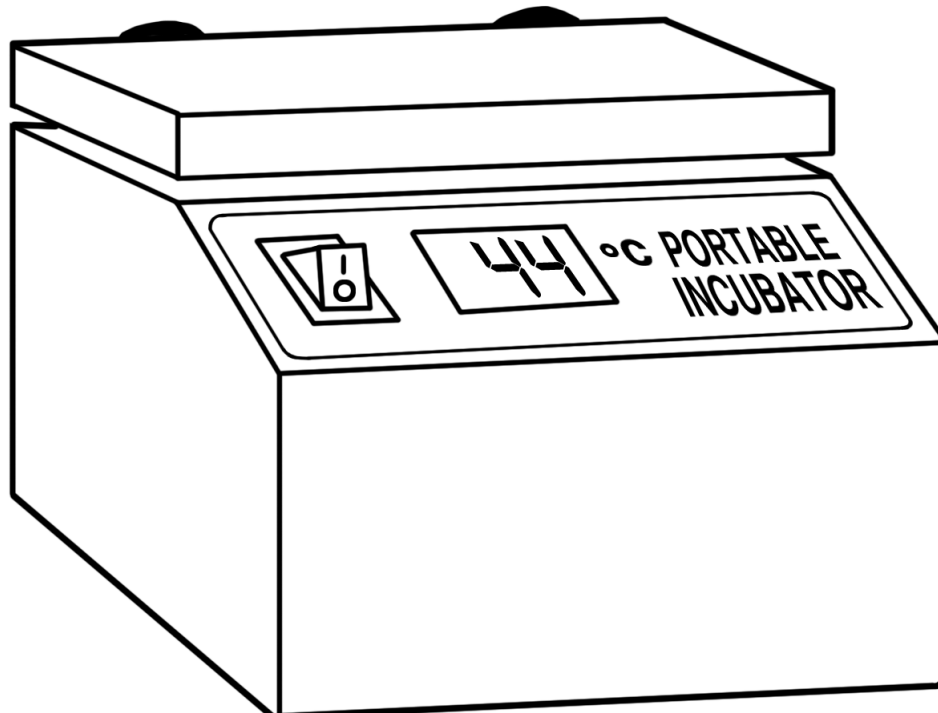

Table of Contents

Section 7: Testing for Microbiological Parameters.....	i
7.1 Introduction	1
7.2 WHO Guidelines for Microbiological Contaminants	2
7.3 Potential Health Effects.....	3
7.3.1 Pathogenic Bacteria.....	4
7.3.2 Pathogenic Viruses.....	4
7.3.3 Pathogenic Protozoa.....	5
7.3.4 Pathogenic Helminths	6
7.4 Infective Dose	6
7.5 Indicator Organisms.....	7
7.5.1 <i>Escherichia coli</i>	9
7.5.2 Thermotolerant Coliforms	9
7.5.3 Total Coliforms.....	10
7.5.4 H ₂ S Bacteria	11
7.6 Test Methods.....	11
7.6.1 Presence-Absence.....	14
7.6.2 Most Probable Number	16
7.6.3 Membrane Filtration	17
7.7 Safe Waste Disposal.....	22
7.8 Summary of Key Information	22
7.9 References	23



7.1 Introduction

Water naturally contains many living things. Most are harmless or even beneficial, but others can cause illness. Living things that cause disease are also known as pathogens. They are sometimes called other names, such as microorganisms, microbes or bugs, depending on the local language and country.

Although there are several contaminants in water that may be harmful to humans, the first priority is to ensure that drinking water is free of pathogens. The greatest risk to public health from microorganisms in water is associated with drinking water that is contaminated with human and animal feces (WHO, 2011).

Globally, an estimated 2,000 children under the age of five die every day from diarrheal diseases and of these some 1,800 deaths are linked to water, sanitation and hygiene (UNICEF Canada, 2013). For every child that dies, countless others suffer from poor health and lost educational opportunities leading to poverty in adulthood.

Having safe drinking water is essential in breaking the cycle of disadvantage and poverty by improving health, the ability to go to school and the strength to work. The WHO estimates that 88% of diarrheal cases are preventable through modifications to the environment, including increasing the availability of safe water, and improving sanitation and hygiene (Prüss-Üstün et al., 2008).

Testing can be done to determine if pathogens are present in the drinking water. However, other indicators, such as the occurrence of diarrheal diseases, can also be important indicators and sometimes more significant than the actual water quality indicators. The general health, well-being or energy levels of the local population can also provide some insight into the quality of the community drinking water.

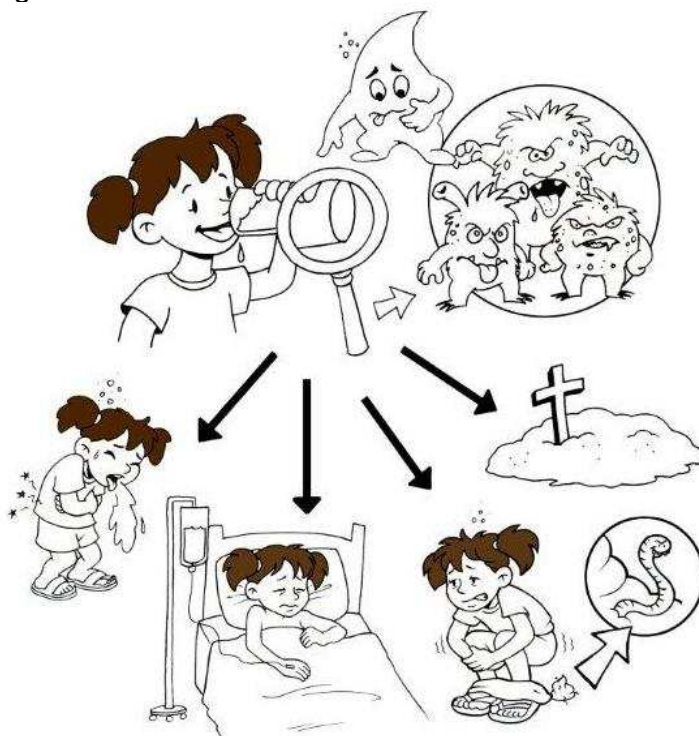

7.2 WHO Guidelines for Microbiological Contaminants

The World Health Organization (WHO) Guidelines for Drinking Water Quality recommend that all water intended for drinking should have zero fecal contamination in any 100 mL sample (WHO, 2011). *Escherichia coli* (also known as *E. coli*) is the preferred indicator organism to demonstrate that there is no fecal contamination in drinking water. However, testing for thermotolerant coliform (TTC) bacteria can be an acceptable alternative in many circumstances (WHO, 2011). See Section 7.5 for an explanation of indicator organisms.

**WHO Guideline for Fecal Contamination in Drinking Water =
0 Fecal Contamination in Any 100 mL Sample**

The WHO recognizes that zero fecal contamination can be difficult to achieve, especially in developing countries where many people rely on household and small community drinking water systems. It is recommended that in these settings, the guideline values should be seen as goals for the future, rather than an immediate requirement (WHO, 2011).

As a result, many developing countries have water quality standards which have more realistic goals for progressive improvement. For example, the national standards for South Africa state that at least 95% of samples should have no thermotolerant (fecal) coliforms, somatic coliphages, enteric viruses or protozoan parasites. However, 4% of samples can have 1 count per 100 mL of these pathogens, and 1% of samples can have up to 10 counts per 100 mL. In spite of this, the goal of drinking water disinfection should be to attain 100% compliance with no contamination detected (SABS, 2001 cited in UNICEF, 2008).

According to the WHO, the risk of fecal contamination in drinking water using *E. coli* as an indicator is shown in the following table. Many relief agencies also use these values to determine when water treatment is required in emergency situations (adapted from MSF, 1994).

Associated Risk for Fecal Contamination in Drinking Water

<i>E. coli</i> Level (CFU/100 mL sample)	Risk ¹	Recommended Action ²
0-10	Reasonable quality	Water may be consumed as it is
11-100	Polluted	Treat if possible, but may be consumed as it is
101-1000	Dangerous	Must be treated
>1000	Very Dangerous	Rejected or must be treated thoroughly

CFU = Colony forming units

(¹ WHO, 1997; ² Harvey, 2007)

7.3 Potential Health Effects

Diseases associated with water can be categorized depending on the source of the pathogen and the route by which we come into contact with the pathogen. Water-borne diseases are those that are caused by drinking water that is contaminated with pathogens. Water quality testing usually focuses on water-borne pathogens that are caused by fecal contamination.

Diseases Associated with Water Contaminated with Pathogens

Possible Diseases	Source	How We Get Sick	How to Stop Getting Sick
Diarrhea, cholera, typhoid, shigellosis, hepatitis A and E, amoebic dysentery, cryptosporidiosis, giardiasis, guinea worm	Water-borne	Drinking water contaminated with pathogens	Treating water to make it safe to drink.
Trachoma, scabies	Water-washed	Pathogens touch the skin or eye	Provide enough water needed for basic hygiene. Improve basic hygiene practices.
Schistosomiasis	Water-based	Pathogens go through the skin	Do not bath or swim in water that is known to be contaminated. Improve water quality by removing or killing the source of pathogens.
Malaria, dengue, yellow fever, filariasis, river blindness, sleeping sickness	Water-insect vector	Pathogens are passed on by insects that breed or live in water, such as mosquitos	Prevent insects from breeding in water. Use pesticides to control insects. Prevent insects from biting by using bed nets and wearing long clothes.

How Water is Contaminated



There are four different categories of pathogens which are discussed in the following sections:
bacteria, viruses, protozoa and helminths.

7.3.1 Pathogenic Bacteria

Bacteria are very small, single-celled organisms that are present everywhere and are the most common living things found in human and animal feces. Drinking water that contains feces is the main cause of water-related diseases.

The most common water-related diseases caused by pathogenic bacteria have diarrhea as a major symptom. These include cholera, typhoid and shigellosis.

Globally, cholera incidence has increased steadily since 2005 with cholera outbreaks affecting several continents, including Sub-Saharan Africa, Asia, and more recently in the Caribbean (Haiti and the Dominican Republic). Cholera continues to pose a serious public health problem among developing world populations that have no access to adequate water and sanitation resources (WHO, 2013).

Between 178,000-589,000 cholera cases were reported annually to the WHO from 2007-2011 (WHO, 2012a). However, the true number of cholera cases is known to be much higher. These numbers are severely underestimated, as many countries do not report or underreport the number of cholera cases. The cases of cholera officially reported do not account for the estimated 500,000-700,000 cases that are called acute watery diarrhea instead of cholera. These cases occur in vast areas of Central and Southeast Asia and in some African countries, leading to great underestimation of the global burden of this disease (WHO, 2013a).

Similar to cholera, typhoid is prevalent in countries that lack access to safe drinking water and sanitation. The true burden of typhoid in developing countries is difficult to estimate. According to recent estimates, 22 million (range 16 to 33 million) cases occur each year causing 216,000 deaths, predominantly in school-age children and young adults (Crump et al., 2004). Asia has the highest incidence of typhoid cases worldwide, especially in Southeast Asian countries and on the Indian sub-continent, followed by Sub-Saharan Africa and Latin America (WHO, 2009a).

The *Shigella* bacteria can cause serious intestinal diseases, including bacillary dysentery. Over two million infections occur each year, resulting in about 600,000 deaths, predominantly in children under ten years of age. Epidemics of shigellosis occur in crowded communities and where hygiene is poor, mainly in developing countries (WHO, 2011).

7.3.2 Pathogenic Viruses

Viruses are the smallest of the microorganisms. Viruses are unable to reproduce by themselves and must use another living thing (e.g., other microorganism, animal or human) to make more viruses. This disrupts the functions or causes the death of the living thing. It is difficult and expensive to study viruses, so we know less about them than other pathogens.

Some pathogenic viruses that are found in water can cause hepatitis A and hepatitis E. Every year there are an estimated 1.4 million cases of hepatitis A (WHO, 2013b) and 20 million cases of hepatitis E leading to 57,000 deaths (WHO, 2013c). Hepatitis E is found worldwide, but the prevalence is highest in East and South Asia.

In developing countries with very poor sanitary conditions and hygienic practices, most children (90%) have been infected with the hepatitis A virus before the age of ten. However, those infected in childhood do not experience any noticeable symptoms and epidemics are uncommon because older children and adults are generally immune. In developing countries with improved sanitary conditions and hygienic practices, countries with transitional economies, and regions where sanitary conditions are variable, children often do not become infected with hepatitis A at a young age. Ironically, these improved economic and sanitary conditions may lead to higher infections in adolescents and adults, and large outbreaks can occur (WHO, 2013b).

Water cannot spread the human immunodeficiency virus (HIV) and influenza viruses. Water does not provide the environment needed for these viruses to survive.

7.3.3 Pathogenic Protozoa

Protozoa are much larger than bacteria and viruses. Some protozoa are parasites that need a living host to survive. They weaken the host by using up their food and energy, damage internal organs, or cause immune reactions.

Entamoeba histolytica, *Cryptosporidium* and *Giardia* are pathogenic protozoa found in water around the world. These protozoa are able to form cysts which let them stay alive without a host and survive in harsh environments. The protozoa cysts become active once the environmental conditions are optimal for their development. The cysts are also highly resistant to disinfection methods used in water treatment.

Entamoeba histolytica, which causes amoebic dysentery, is the most prevalent intestinal pathogenic protozoa worldwide. Amoebic dysentery affects around 500 million people each year. The potential for water-borne transmission is greater in tropical rather than temperate climates (WHO, 2011).

Cryptosporidium is highly resistant to chlorine disinfection and is relatively small in size (compared to other protozoa, but they are still much bigger than bacteria and viruses) so it can also be difficult to remove by some types of filters (e.g., slow sand filters). Many water-borne outbreaks of cryptosporidiosis have been reported globally, including industrialized countries where large-scale conventional water treatment systems are used, such as in the USA and United Kingdom. Most of the outbreaks were caused by poor operation or failures in the water treatment and distribution systems. But more importantly, many outbreaks occurred in systems where the water quality was considered to be safe and met national standards and WHO Guidelines for *E. coli* levels and turbidity (WHO, 2009).

Giardia can be spread in different ways. By far the most common transmission route is person-to-person contact, particularly between children. Contaminated drinking water is also a possible transmission route and has been associated with outbreaks (WHO, 2011). Giardiasis is a global disease. It infects nearly 2% of adults and up to 8% of children in developed countries. Nearly 33% of people in developing countries have had giardiasis (Kappus *et al.*, 1994 cited in CDC, 2011).

7.3.4 Pathogenic Helminths

Helminths, more commonly known as worms or flukes, require a host body to survive and are generally passed in human and animal feces. They spend part of their life in hosts that live in water before being transmitted to humans. Many types of worms can live for several years and weaken their host by using up their food. Helminths are larger than viruses, bacteria and protozoa and are often visible to the naked eye.

For most helminths, drinking water is not a significant route of transmission. Helminths normally pass through people's skin when they bathe or swim in contaminated water, and do not normally infect people by drinking water. There are two exceptions: *Dracunculus medinensis* (guinea worm) and *Fasciola* (liver flukes). Dracunculiasis and fascioliasis both need intermediate hosts to complete their life cycles, but are transmitted through drinking water by different mechanisms. Other helminths can be transmitted through water contact (e.g., schistosomiasis) or are associated with using untreated wastewater in agriculture (e.g., ascariasis, hookworm), but are not usually transmitted through drinking water (WHO, 2011).

7.4 Infective Dose

The minimum number of pathogens needed to make somebody sick is called the infective dose. The presence of a pathogen in water does not always mean that it will make someone sick. The infective dose is different depending on the type of pathogen. Generally, bacteria have a higher infective dose than viruses, protozoa and helminths. This means with some bacteria, larger numbers need to be ingested in order to make person sick.



that
2

A high infective dose is defined as needing between 1-100 microorganisms to make somebody sick, a moderate infective dose means that 100-10,000 microorganisms are needed, and a low infective dose means that more than 10,000 microorganisms are needed (WHO, 2011). Generally, bacteria have a lower infective dose than viruses, protozoa and helminths (i.e., it takes more bacteria than other pathogens to infect a person).

Infants, young children, the sick and elderly generally have a lower infective dose than an average adult. This means that they are most at risk and more likely to die from water-related diseases. In developing countries, over 90% of all diarrheal deaths occur in children under five years of age (WHO/UNICEF, 2005).

Relative Infectivity of Pathogens Transmitted Through Drinking Water

Pathogen	Relative Infective Dose ¹	Health Significance ²	Persistence in Water Supplies ³	Resistance to Chlorine ⁴
Bacteria				
<i>Escherichia coli</i> (pathogenic)	Low	High	Moderate	Low
<i>Salmonella typhi</i>	Low	High	Moderate	Low
<i>Shigella</i>	High	High	Short	Low
<i>Vibrio cholerae</i>	Low	High	Short to long	Low
Viruses				
Hepatitis A virus	High	High	Long	Moderate
Hepatitis E virus	High	High	Long	Moderate
Protozoa				
<i>Cryptosporidium hominis/parvum</i>	High	High	Long	High
<i>Entamoeba histolytica</i>	High	High	Moderate	High
Helminths				
<i>Dracunculus medinensis</i>	High	High	Moderate	Moderate
<i>Schistosoma</i>	High	High	Short	Moderate

¹ From experiments with human volunteers, from epidemiological evidence and from experimental animal studies. High means infective doses can be 1-100 microorganisms, moderate 100-10,000, and low >10,000.

² Health significance relates to the incidence and severity of disease, including association with outbreaks.

³ Detection period for infective stage in water at 20°C: short, up to 1 week; moderate, 1 week to 1 month; long, over 1 month.

⁴ When the infective stage is freely suspended in water treated at conventional doses and contact times and pH between 7 and 8. Low means 99% inactivation at 20°C generally in <1 min, moderate 1-30 min and high >30 min.

(Adapted from WHO, 2011)

7.5 Indicator Organisms

There are many different kinds of pathogens and it would be too expensive and time consuming to test for each one. Instead, since most diarrhea-causing pathogens come from feces, it is more practical to test for a sign of feces in water. We can test for fecal contamination in drinking water by using indicator organisms, usually bacterial indicator organisms. These are microorganisms whose presence in water indicates the likely presence of feces, and possibly, pathogens.

According to the WHO (2011), indicator organisms for fecal contamination should have the following characteristics:

- Be universally present in large numbers in the feces of humans and animals
- Not multiply in natural waters
- Survive in water in a similar manner to fecal pathogens
- Be present in higher numbers than fecal pathogens
- Respond to treatment processes in a similar manner to fecal pathogens
- Be readily detected by simple, inexpensive culture methods
- Should not be pathogenic themselves

There are several types of indicators, each with certain characteristics. *E. coli* and thermotolerant (TTC) coliforms are the two main bacterial indicators used for water quality testing. As shown in the following diagram, *E. coli* is a type of thermotolerant coliform, and thermotolerant coliforms are a type of total coliforms. These indicators are described in more detail in the following sections.

Bacterial indicators, such as *E. coli* and thermotolerant coliforms, are not intended to be absolute indicators for the presence of pathogens in drinking water. Rather the presence of these bacterial indicators in a water sample means that the water was likely contaminated with feces and is at a higher risk for causing disease.

Indicator Bacteria Groups

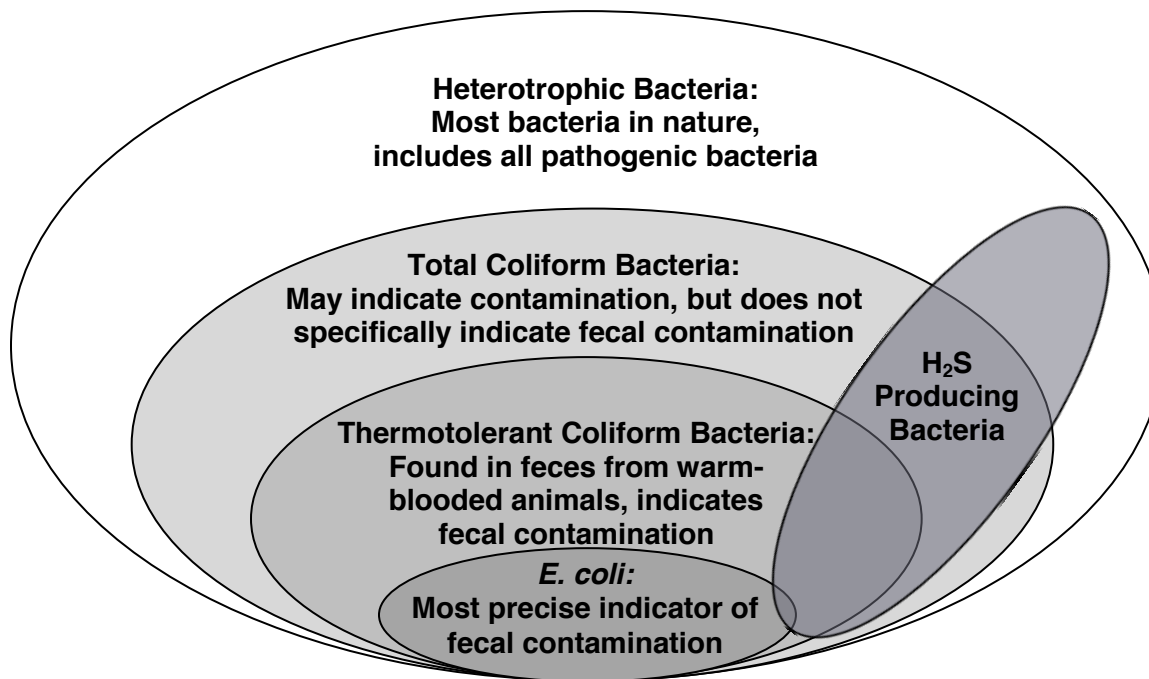

The presence of bacterial indicators does not always correlate with the presence of protozoa or viruses in drinking water, and vice versa. There are many cases of water-borne disease outbreaks in which the drinking water met all requirements for bacteriological water quality.

Bacterial indicators are significantly more susceptible to chlorine than some other pathogens (e.g., protozoa, viruses). Also, some water treatment processes may remove coliforms, but not viruses, which are much smaller. For these reasons, water without *E. coli* or thermotolerant coliforms should be seen as low-risk, rather than completely safe.

(BCCDD, 2006; UNICEF, 2008)

7.5.1 *Escherichia coli*

E. coli is the most important indicator used in drinking water quality testing and has been used for over 50 years. It is a thermotolerant coliform bacteria found mainly in the feces of warm-blooded animals, including humans. Water that is highly polluted with fecal matter may have *E. coli* levels of tens of millions of bacteria per litre. The majority of *E. coli* is harmless; however, there are some strains (such as O157:H7) that are pathogenic and known to cause severe diarrhea and other symptoms.

E. coli has similar biochemical properties to the other coliforms and is distinguished by the presence of the enzyme beta-glucuronidase (beta-gluc) and beta-galactosidase (beta-gal). Many water testing methods use the presence of the beta-gluc enzyme for detecting *E. coli* in water samples. Over 95% of *E. coli* tested thus far possesses this enzyme.

E. coli is to date one of the best indicators for fecal contamination in drinking water. However, there is some evidence that *E. coli* are able to multiply in nutrient-rich tropical soils, although it is generally recognised that this phenomenon is limited: in most cases the indigenous bacteria would out-compete the *E. coli* (WHO, 2012b). Nevertheless, the presence of *E. coli* in a drinking water sample represents an immediate public health concern.



CAWST recommends that *E. coli* be used as the indicator organism for microbiological testing.

7.5.2 Thermotolerant Coliforms

Thermotolerant coliforms (TTC) are a subgroup of the total coliform group. They used to be commonly referred to as fecal coliforms (FC) since they are found in warm-blooded animals. Among the coliforms in human feces, 96.4% are thermotolerant coliforms. Thermotolerant coliforms are distinguished from total coliforms by their ability to grow at higher temperatures (42-44.5°C). They are more closely associated with fecal pollution than total coliforms (BCCDC, 2006).

Historically, thermotolerant coliforms were extensively used as bacterial indicators of fecal contamination. Even though *E. coli* has replaced thermotolerant coliforms as a more specific indicator of fecal contamination, the presence of thermotolerant coliforms in a drinking water sample also represents an immediate public health concern.



E. coli has replaced thermotolerant coliforms as the preferred indicator since it is a more precise indicator of fecal contamination. However, thermotolerant coliforms are an acceptable indicator if it is not possible to test for *E. coli*.

**Thermotolerant Coliforms Excreted in the Feces of Warm-Blooded Animals
(average numbers per gram wet weight of feces)**

Animal	Number of Thermotolerant Coliforms
Duck	33,000,000
Dog	23,000,000
Sheep	16,000,000
Human	13,000,000
Cat	7,900,000
Pig	3,300,300
Chicken	1,300,000
Turkey	290,000
Cow	230,000
Horse	12,600

(Adapted from WHO, 2001)

7.5.3 Total Coliforms

Total coliforms (TC) were used as an indicator of drinking water since the early 1900s and are commonly used in testing wastewater. However, new research has shown that total coliforms are not useful as an indicator of fecal contamination in drinking water, and they have no sanitary or public health significance (WHO, 2011).

Originally, total coliforms included four groups of bacteria: *Escherichia*, *Klebsiella*, *Enterobacter* and *Citrobacter*. These four groups are found in the feces of warm-blooded animals, including humans. However, recent scientific evidence has shown that total coliforms actually include a much broader group of bacteria than the four original groups. In fact, to date there are now 19 recognized groups of bacteria that fall under total coliforms, of which only ten of these groups have actually been associated with feces (BCCDC Environmental Health Laboratory Services, 2006).

Several groups of bacteria in the environment that are included as total coliforms are associated with soil, vegetation, or water sediments. Therefore, not all total coliforms represent bacteria coming from feces. Recent research has also shown that some groups of total coliforms that are found in animal feces are also capable of multiplying in natural water. This makes it difficult to determine whether the water was contaminated with feces or not.

Overall, total coliforms should not be used as an indicator of fecal contamination in drinking water. Total coliforms do not meet the two basic criteria for a good indicator organism: 1) to only be associated with the feces of animals, and 2) to not multiply in natural waters.



CAWST does not recommend using total coliforms as the indicator organism for microbiological testing.

7.5.4 H₂S Bacteria

Hydrogen sulphide (H₂S) bacteria were reported in 1982 as a simple way to indicate fecal contamination in drinking water (Manja et al., 1982 cited in UNICEF, 2008). The authors noted that water containing coliform bacteria also consistently contained organisms that produced H₂S.

The H₂S test does not specifically test for standard indicator bacteria, such as *E. coli* or thermotolerant coliforms. Rather, a large number of bacteria can produce H₂S (e.g., *Citrobacter*, *Enterobacter*, *Salmonella*, *Clostridium perfringens*). Most of these bacteria come from feces. However, fecal bacteria are not the only bacteria that produce H₂S. Sulphate-reducing bacteria (which do not come from feces) and water that has naturally high sulfide levels (this is particularly true in groundwater) will also make the H₂S test turn positive. Therefore, you should be cautious when using H₂S as an indicator of water quality since there are possible sources other than fecal contamination that can give a positive result (WHO, 2002).

7.6 Test Methods

There are several factors to be taken into consideration when choosing an appropriate microbiological test method, including:

- Available resources
- Required level of accuracy and precision
- Technical skills of staff
- Geographical location
- Objective of the results

There are three main test methods to determine the presence of indicator bacteria in drinking water:

- Presence/absence (P-A)
- Most probable number (MPN)
- Membrane filtration

Traditionally, membrane filtration using international standard methods was recommended to test for indicator bacteria in drinking water. This method requires trained technicians, equipment and other supporting materials that were historically only available in a conventional laboratory. The relatively high cost of membrane filtration made it difficult, impractical or impossible to perform these tests in many parts of the world.

These constraints highlighted the great need for rapid, simple and inexpensive test methods. This need is especially great for small community and household water supplies that lack access to and cannot afford conventional laboratory testing. On-site testing using portable test kits and the development of alternative and simplified testing methods, such as P-A or MPN tests, have contributed to overcoming these constraints (WHO, 2002).

Different equipment and products for these test methods are now widespread and commercially available. The following sections discuss the different test methods, how they are conducted, and their advantages and limitations. Appendix 2 provides Product Sheets for different test equipment and consumable items.



Results from one microbiological test method are not directly comparable to another (e.g., MPN versus membrane filtration). Different test methods have different sensitivities for indicator bacteria. Although tests intend to target the same group of indicator bacteria (e.g., thermotolerant coliforms), different test methods are based on specific biochemical properties of the indicator bacteria. One method can, for example, detect more thermotolerant coliforms than another (Adapted from BCCDC, 2006).

Most presence-absence, most probable number and membrane filtration tests are based on one of the following test methods: presumptive or enzyme substrate.

Presumptive Test Method

Presumptive tests are the traditional method that was used for identifying indicator bacteria in drinking water. As coliform bacteria grow, they ferment lactose and produce gas, changing the colour of the culture media and making bubbles. Since some noncoliform bacteria can also ferment lactose, this first test is called a “presumptive” test. Bacteria from a positive test can then be grown with a culture media that tests more specifically for coliforms, leading to “confirmed” results. Finally, the test can be “completed” by taking positive samples from the confirmed test through additional identification steps. Each of the three steps (presumptive, confirmed and completed) needs 1-2 days of incubation. Typically only the first two steps are performed in coliform and thermotolerant coliform tests, while all three phases are done for periodic quality control or for positive identification of *E. coli*.

Enzyme Substrate Test Methods

In recent years, tests have been developed that chemically identify specific enzymes produced by particular indicator bacteria. These enzymes react with specific substrates in the culture media and generally produce a strong colour change that is easy to identify. These tests are more rapid than the presumptive test method: some can produce results in 24 hours or less. Furthermore, they are more specific than presumptive tests; so confirmatory tests are generally not necessary. The main disadvantage is the higher cost to purchase enzyme substrate tests. As well, the culture media doesn't exist in powder form. It is most often in liquid or agar form which needs to be refrigerated. Two of the most relevant enzyme tests for drinking water are described briefly below.

Beta-galactosidase (Beta-gal): Coliform bacteria produce the beta-gal enzyme. A number of specific substrates have been developed which react with this enzyme to produce a strong colour, usually yellow or deep red.

Beta-glucuronidase (Beta-gluc): Over 95% of *E. coli* produce the beta-gluc enzyme. This enzyme reacts with the substrate 4-methylumbelliferyl-beta-D-glucoside (MUG) to produce a chemical that glows blue when exposed to ultraviolet light. Other substrates can produce a visible colour, typically blue (e.g., 4-chloro-3-indolyl-beta-D-glucuronide, also known as X-gluc).

Many commercially available P-A, MPN and membrane filtration tests use enzyme substrate methods. These tests are recommended by CAWST for their simplicity and specificity and are the basis of the discussion for culture media in this Manual. See Appendix 5 for a summary of different culture media for membrane filtration.

(Adapted from UNICEF, 2008)

7.6.1 Presence-Absence

Presence-absence (P-A) is a qualitative test that depends on a colour change to indicate the presence of contamination. If the test turns out to be positive, meaning that the indicator bacteria is present, the water sample will change to a specific colour. P-A tests will not tell you the quantity of indicator bacteria in the water sample.

P-A tests are generally only appropriate in circumstances where thermotolerant coliforms are rarely found and when contamination occurs only at low levels (e.g., in deep wells). Quantitative test methods, like MPN and membrane filtration, are preferred where there is known or likely fecal contamination in the drinking water. For example, quantitative test methods are better when testing a surface water source or unprotected well. If positive results are found using P-A testing, the water sample should be re-tested using either MPN or membrane filtration to confirm the level of contamination.

P-A testing is not appropriate for testing the treatment effectiveness of household water treatment (HWT) technologies. We already know that many of these technologies may not be 100% effective for bacteria removal, so there is a chance that P-A tests will turn positive when testing the treated water. The P-A test will not indicate the level of contamination, despite the fact that the treated water quality is improved compared to the original water source, or help to determine the removal effectiveness of HWT technologies.

The advantages of P-A tests are that they are relatively inexpensive, quick and easy to use. The main limitation is that it will only measure positive or negative; the results do not tell you the actual number of indicator bacteria in the sample.

Summary of Presence-Absence Advantages and Limitations

Advantages	Limitations
<ul style="list-style-type: none"> • Simple to understand and use (requires minimal training) • Achieves results rapidly (within 24 hours) • Some tests do not require extra equipment (e.g., incubator) • Portable and durable in the field • Inexpensive for a limited number of tests 	<ul style="list-style-type: none"> • Only provides qualitative results; does not indicate the quantity of bacteria • Not recommended by WHO for testing surface water and untreated small community supplies • Not able to determine the removal effectiveness of HWT technologies



P-A tests are designed to be used where the water is *most likely not polluted* (i.e., the test result is negative), such as groundwater and community water supplies that are treated and piped to people's homes. If the P-A test turns positive, then further microbiological testing is recommended using either MPN or membrane filtration.

There are a number of commercially available P-A tests which use enzyme substrate methods. See Appendix 2 for Product Sheets for some different P-A test manufacturers. Bain *et al.* (2012) have also developed a catalogue of different P-A tests that are appropriate for using in developing countries (see References for the free document that is available online).

Different P-A products can test for three types of indicator bacteria:

1. H₂S producing bacteria
2. Total coliform bacteria
3. Total coliform bacteria and *E. coli*

There are different P-A tests using H₂S bacteria that are produced by different manufacturers. For example, in the P-A test manufactured by ENPHO in Nepal, a strip of test paper is added to a water sample. If the test paper turns black within 24 hours, it means that H₂S was produced, which means that bacteria coming from feces are likely present in the water sample.

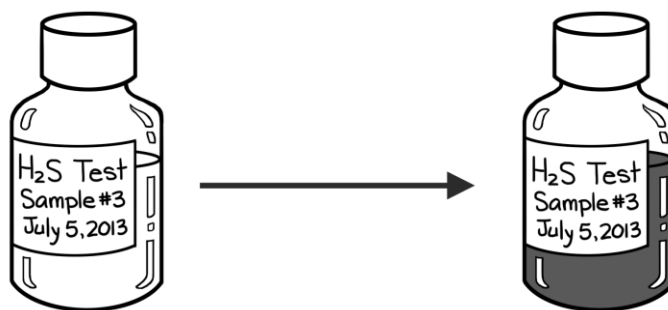

Black water indicates a positive result for H₂S bacteria and likely fecal contamination

There are also different P-A tests that use total coliform and/or *E. coli* as the indicators. The general process for these tests is:

1. A powdered reagent is added to the water sample
2. The sample is incubated for 24-48 hours at 35°C
3. The results are read: Colourless = negative, Colour = total coliforms present, Fluorescent = *E. coli* present (seen using a UV lamp)



Clear water indicates a negative result for total coliforms, coloured water indicates total coliforms are present, fluorescent water indicates *E. coli* is present (seen using a UV lamp)

7.6.2 Most Probable Number

The most probable number (MPN) test method estimates the number of indicator bacteria that is most likely to be present in the water sample.

Multiple samples (1-10 mL) of the same water to be tested are added to a culture media in sterile tubes and incubated at a particular temperature for a fixed time (usually 24 hours). Three or five tubes are commonly used, though ten tubes may be used for greater sensitivity.

It is becoming more popular to use a disposable tray with multiple small wells instead of multiple tubes since it simplifies the procedure. By counting the number of tubes or wells showing a positive result and comparing with a standard table, a statistical estimate of the most probable number of bacteria can be made. The results are reported as MPN per 100 mL (UNICEF, 2008).

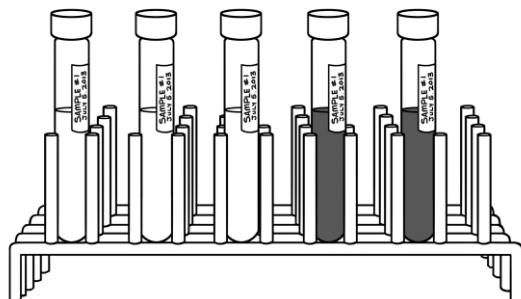

Multiple tubes (10 mL each)

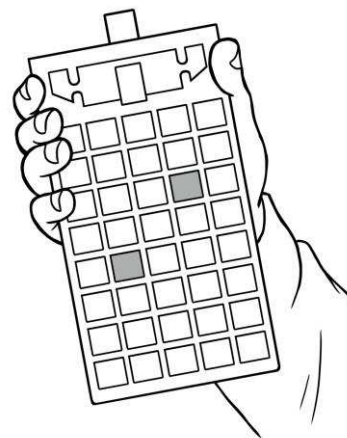

Multiple wells in a disposable tray

The following table is an example to determine the MPN of indicator bacteria in a water sample using a ten tube test. Note that the MPN index is specific to the product and you need to refer to the manufacturer's instructions to calculate the colony forming units (CFU) per 100 mL.

Example MPN Index for 10 Tubes

Number of Positive Tubes	0	1	2	3	4	5	6	7	8	9	10
MPN Index (CFU/100 mL)	<1.1	1.1	2.2	3.6	5.1	6.9	9.2	12.0	16.1	23.0	>23

MPN testing is relatively simple when using the trays, although some training may be required. This method has become more popular for testing *E. coli* in the field, especially with academic researchers. It uses a lower incubation temperature, 35°C instead of 44.5°C, which is less stressful on the bacteria. Another important advantage is that it can be used to test turbid water, which is more difficult to test with membrane filtration.

The main limitation of using the MPN tray method is that the result is a statistical approximation (UNICEF, 2008). It can also become quite expensive when you need to do a lot of testing and the disposable trays produce a lot of waste.

Summary of MPN Advantages and Limitations

Advantages	Limitations
<ul style="list-style-type: none"> • Provides semi-quantitative results • Relatively simple to understand and use • Relatively inexpensive for occasional testing • Can be used with turbid water 	<ul style="list-style-type: none"> • Results are a statistical estimate • More labour intensive than P-A testing • Requires some training • Requires more equipment than P-A testing (e.g., power source, incubator, pipettes) • Not practical if needing to test many (>10) samples at a time

See Appendix 2 for Product Sheets for some different MPN test manufacturers. Bain *et al.* (2012) have also developed a catalogue of different MPN tests that are appropriate for using in developing countries (see the References section for the free document that is available online).

7.6.3 Membrane Filtration

Membrane filtration (MF) is the most accurate method to determine the number of indicator bacteria in a water sample and is internationally recognized as a standard method for water quality testing.

Membrane filtration can be done in a laboratory or by using a portable test kit. In general, a 100 mL water sample is vacuumed through filter paper using a small hand pump. After filtration, the bacteria remain on the filter paper which is then placed in a Petri dish with a nutrient solution (also known as culture media). The Petri dishes are placed in an incubator at a specific temperature and time which can vary according the type of indicator bacteria and culture media. After incubation, the bacteria colonies can be seen with the naked eye or using a magnifying glass. The size and colour of the colonies depends on the type of bacteria and culture media used. The bacteria colonies are counted to determine the number of colony forming units (CFU) per 100 mL.

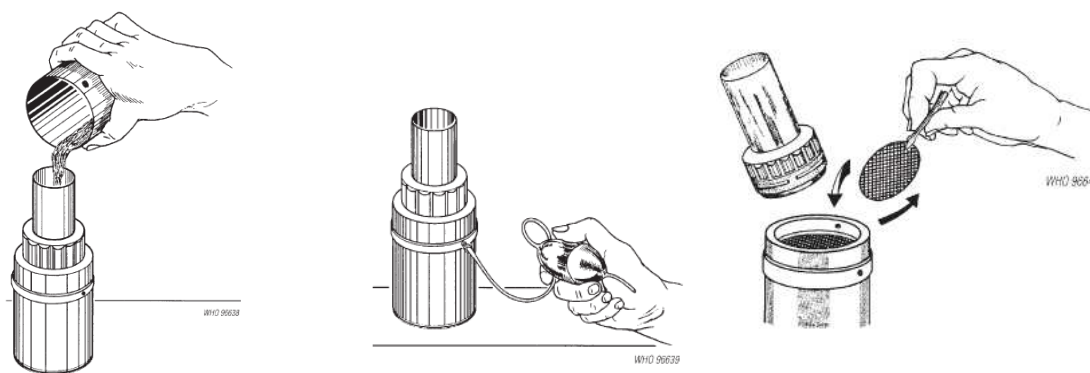

1- Pouring the water sample into a portable membrane filter setup, 2- vacuuming the water through filter paper using a small hand pump, 3- removing the filter paper with the bacteria from the water sample (Credit: WHO, 1997)

Membrane filtration is highly reproducible and can be used to test relatively large volumes of water samples. However, it also has limitations, particularly when testing waters with high turbidity or large numbers of noncoliform (background) bacteria. Turbidity caused by the presence of algae or suspended particles can clog the membrane or prevent the growth of indicator bacteria on the filter paper. Low coliform estimates may be caused by the presence of high numbers of noncoliform bacteria, toxic metals or toxic organic chemicals (e.g., phenols).

Summary of Membrane Filtration Advantages and Limitations

Advantages	Limitations
<ul style="list-style-type: none"> • Provides quantitative results • Most accurate method to determine the number of indicator bacteria; results are obtained directly by counting the number of indicator bacteria colonies • Many samples can be tested at once • Internationally recognized test method 	<ul style="list-style-type: none"> • More labour intensive than P-A or MPN testing • More complicated to understand and read results; requires more training • Requires more equipment than P-A and MPN testing (e.g., power source, incubator, pipettes, filter paper, Petri dishes) • More difficult to test turbid water (i.e., dilution is required) • Cost of consumables can be expensive

See Appendix 2 for Product Sheets of portable test kits that use membrane filtration.

Filter Paper

Filter paper, also called a membrane filter, is used to trap the bacteria from the water sample. A pore size of 0.45 μm is most commonly used since it filters out all coliform bacteria. The filter paper usually has a grid printed on it so that you can more easily count the bacteria colonies. There are various types of filter papers with different grid colours available from manufacturers. See Appendix 2 for a Product Sheets that summarizes filter paper manufacturers.

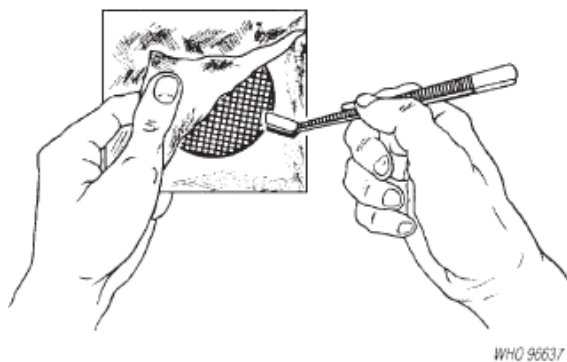

WHO 96637

Removing a filter paper from its sterile package (Credit: WHO, 1997)

Culture Media

Bacteria cannot be seen with the human eye. In order to observe them, they are “grown” under controlled conditions to a size that we can actually see and count them. Culture media are substances which contain nutrients to help the bacteria grow. Culture media in liquid form is called a broth and the semi-solid form (gel) is called an agar. Different culture media are used to grow different indicator bacteria.

In most cases, the culture media is poured onto an absorbent pad in a Petri dish. The filter paper with the bacteria is then put on top and soaks up the culture media. The Petri dish with the culture media and filter paper is incubated so that the bacteria will replicate hundreds of thousands of times and eventually appear on the Petri dish as small dots called colonies. The number of colonies formed on the media is reported as colony forming units (CFU) per unit of volume of the water sample (i.e., 100 mL), hence CFU/100 mL.

Different culture media products have different storage requirements and expiration dates. Once opened the media is exposed to contamination and should be stored securely. Be sure to follow the manufacturer’s instructions on how to properly use and store the culture media.

Appendix 5 provides a table with the most commonly used culture media and their specifications. Bain *et al.* (2012) have also developed a catalogue of different culture media that are appropriate for using in developing countries (see References for the free document that is available online).

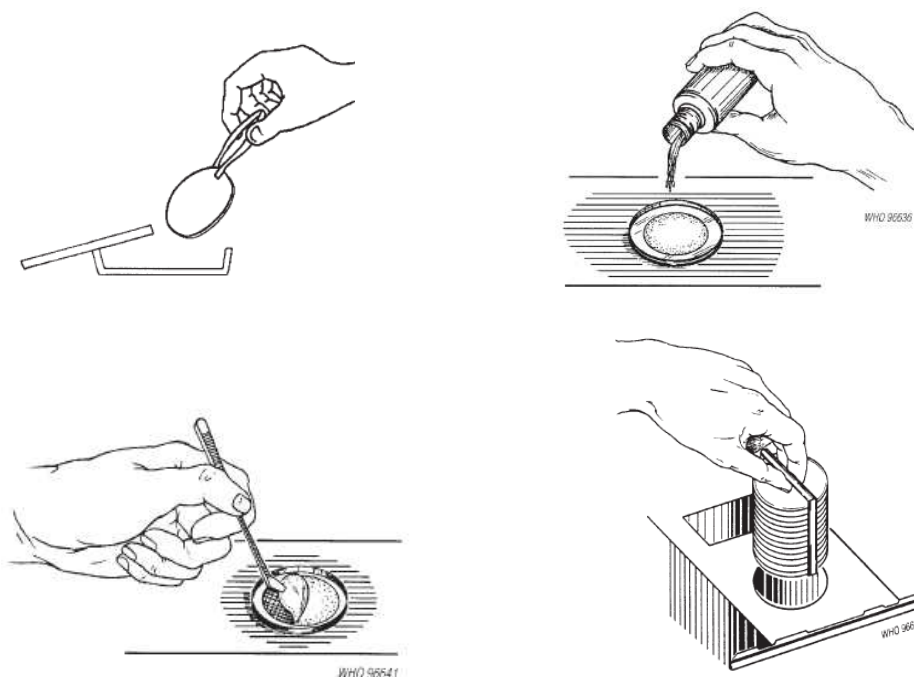

1- An absorbent pad is put into the Petri dish, 2- the culture media is poured on top, 3- the filter paper with the bacteria is added, and 4- the Petri dish is put into the incubator (Credit: WHO, 1997)

Summary of Culture Media

<p>Nutrient Pads are prepared with dehydrated broths in plastic Petri dishes.</p> <p>They require rehydration with 2-3 mL of distilled water in each Petri dish.</p> <p>These Petri dishes cannot be reused.</p> <p><i>Notes:</i></p> <ul style="list-style-type: none"> • Nutrient pads are practical, since they minimize contamination and there is no preparation required • They can be expensive for many tests and are bulky for transport 	<p>Broths can be found in powder form (requires preparation with distilled water) or liquid form (no preparation needed).</p> <p>Agars need to be prepared by mixing the agar powder with water and heating. When the media is still liquid, it is poured into Petri dishes. It will become a semi-solid gel at room temperature.</p> <p><i>Notes:</i></p> <ul style="list-style-type: none"> • Liquid broths don't require preparation • Powder broths are generally the most economical for more than 200 tests • Powders don't require strict storage, but liquid broths need to be refrigerated • Agars require taller Petri dishes and need to be prepared in advance • Pre-poured agar plates can also be purchased, but tend to be the most expensive • Broths are more commonly used than agars for field testing
--	---

Resuscitation

Bacteria are alive and are stressed after the filtration process. Stressed bacteria do not grow well and may die if they are further stressed by heat. Therefore, you should wait 1-4 hours at room temperature before incubating samples to allow bacteria time to recover and ensure that they survive and grow.

Incubator

The incubator is another important piece of equipment needed for membrane filtration, and sometimes for P-A and MPN tests. There are different types of incubators made by different manufacturers. Some incubators are portable and use a battery for power supply, while others need to stay in one location and use the main power supply.

The incubation temperature is critical to ensure that microbiological test results are accurate. Different culture media require different temperatures to grow the specific indicator bacteria. For example, thermotolerant coliforms grow at 44°C. The manufacturer of the culture media will give instructions on the temperature needed for incubation.

Incubators need to be calibrated on a regular basis to make sure that the temperature is accurate. Manufacturers will give instruction on how often to calibrate the incubator and the process to do so.

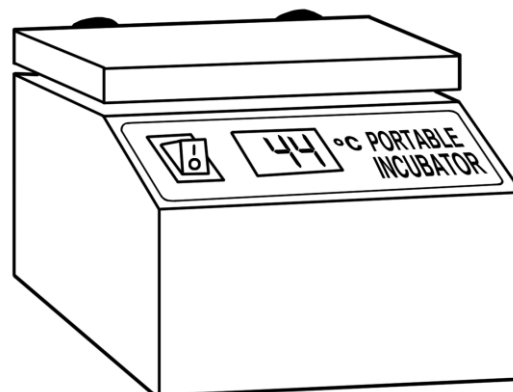

Colony Counting Techniques

After incubation, you remove the Petri dishes and count the bacteria colonies. You will count all colonies of a certain colour, depending on the indicator bacteria and the culture media used.

Colonies may vary considerably in size. Generally, where there are a large number of colonies, they are smaller in diameter. Where colonies are fewer, they tend to be larger. This is because the colonies compete for nutrients in the culture media and will grow larger when there is no competition.

Use the grid lines on the filter paper to help count large numbers of colonies. Examine and count all colonies with the particular colour you are looking for. Colonies shown in every grid square are counted. Go from top to bottom and left to right until all grid squares are covered.

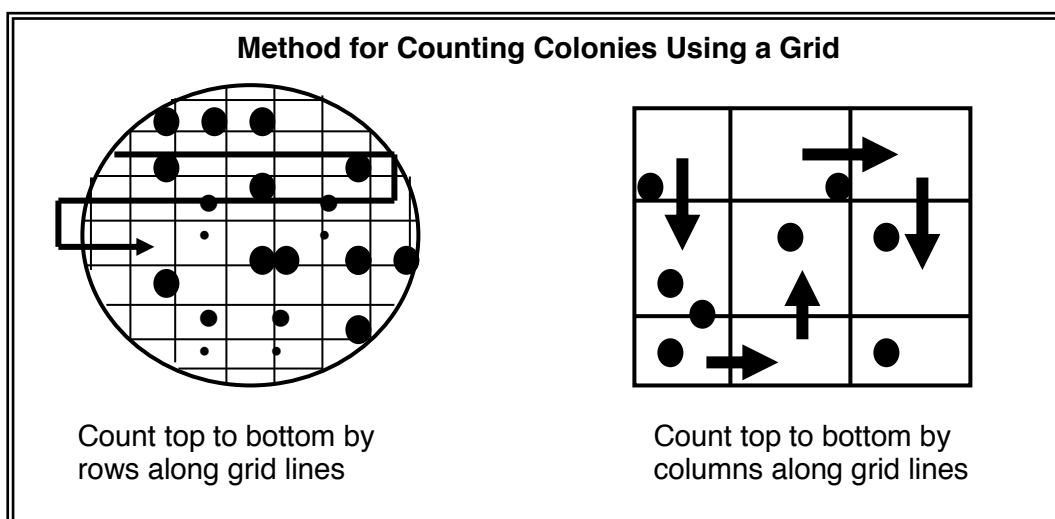

You will report the number of colony forming units (CFU) per 100 mL of water sample. It is difficult to count more than 100 colonies. Petri dishes with more than 200 colonies can be reported as “too numerous to count” (TNTC). Some colonies may overlap which can cause counting errors. Dilutions can be made to reduce the number of colonies and make it easier to count. See Section 4: Water Sampling and Quality Control for instructions on how to dilute your water sample.

Most culture media manufacturers provide an information sheet or troubleshooting guide which can help you to identify and count the colonies.



When testing for both total and thermotolerant coliforms (or *E. coli*), remember that the total coliform count must include the thermotolerant coliform (or *E. coli*) colonies. For example with m-ColiBlue culture media, if you count 10 red general coliform colonies and 5 blue *E. coli* colonies, then the total coliform count is 15, not 10, as *E. coli* is also part of the total coliform group.

7.7 Safe Waste Disposal

Bacteria cultures must be disposed of safely and properly as each colony is made up of millions of individual bacteria. Contaminated material (e.g., Petri dishes, test bottles, test tubes, absorbent pads, filter paper) must be disinfected before disposal or reuse. This can be done by using one of the following options:

1. Add liquid chlorine (bleach) to each Petri dish (about 2 mL) or test bottle until full. After 10 minutes of contact time with the bleach, pour the liquid down the drain and flush with plenty of water to dilute the bleach. Burn the solid waste materials, if possible; otherwise dispose of the solid waste in the garbage.
2. Place contaminated material (e.g., Petri dishes, absorbent pads, filter paper) into boiling water for at least 10 minutes. You may wish to do this outside as the smell may become unpleasant. Burn the solid waste materials, if possible; otherwise dispose of the solid waste in the garbage. Use a designated garbage bag and try not to mix the waste with common municipal waste.
3. Place open test bottles, Petri dishes, absorbent pads and filter papers into a bucket which contains at least a 70 mL of bleach mixed with 2 litres of water. Allow at least 1 hour contact time, then boil the Petri dishes for 10 minutes to fully disinfect them and to wash off the bleach. Burn the solid waste materials, if possible; otherwise dispose of the solid waste in the garbage. Use a designated garbage bag and try not to mix the waste with common municipal waste.

Always wash your hands thoroughly with soap after handling the contaminated waste and before touching clean and sterilized equipment. If possible, you should wear disposable gloves.

7.8 Summary of Key Information

- Although there are several contaminants in water that may be harmful to humans, the first priority is to ensure that drinking water is free of pathogens. The greatest risk to public health from microorganisms in water is associated with drinking water that is contaminated with human and animal feces (WHO, 2007).
- The WHO Guidelines for Drinking Water Quality recommend that all water intended for drinking should have zero fecal contamination in any 100 mL sample (WHO, 2011).
- The WHO recognizes that zero fecal contamination can be difficult to achieve, especially in developing countries where many people rely on household and small community drinking water systems. It is recommended that in these settings, the guideline values should be seen as goals for the future, rather than an immediate requirement (WHO, 2011).
- There are many different kinds of pathogens and it would be too expensive and time consuming to test for each one. We can test for fecal contamination in drinking water by using indicator organisms, usually bacterial indicator organisms. These are microorganisms whose presence in water indicates the likely presence of feces, and potentially, pathogens.
- *Escherichia coli* (also known as *E. coli*) is the preferred indicator organism to demonstrate that there is no fecal contamination in drinking water. However, testing for thermotolerant coliform bacteria can be an acceptable alternative in many circumstances (WHO, 2011).

- Testing for every conceivable pathogen in water would be both time consuming, complicated and expensive. Alternatively, the presence or absence of certain bacterial indicator organisms is used to determine the safety of the water. The most commonly used indicator for fecal contamination is *E. coli*.
- There are three main testing methods to determine the presence of indicator bacteria in drinking water: 1) presence-absence, 2) most probable number and 3) membrane filtration.
- Different products for each of the test methods are now widespread and commercially available. Appendix 2 gives Product Sheets for different equipment and consumable items.
- Presence-absence (P-A) is a qualitative test that depends on a colour change to indicate the presence of contamination. If the test turns out to be positive, meaning that the indicator bacteria is present, the water sample will change to a specific colour. P-A tests will not tell you the quantity of indicator bacteria in the water sample.
- The most probable number (MPN) test method estimates the number of indicator bacteria that is most likely to be present in the water sample.
- Membrane filtration is the most accurate method to determine the number of indicator bacteria in a water sample. It is internationally recognized as a standard method for water quality testing.

7.9 References

Bain, R., Bartram, J., Elliott, M., Matthews, R., McMahan, L., Tung, R., Chuang, P. and S. Gundry (2012). A Summary Catalogue of Microbial Drinking Water Tests for Low and Medium Resource Settings. International Journal of Environmental Research and Public Health, 2012, 9, 1609-1625. Available at: www.mdpi.com/1660-4601/9/5/1609

BCCDC Environmental Health Laboratory Services (2006). Safe Drinking Water: Public Health Laboratory Surveillance Update. British Columbia, Canada. Available at: www.vch.ca/media/Safe%20Drinking%20Water_%20Public%20Health%20Laboratory%20Surveillance.pdf

Crump, J., Luby, S. and E. Mintz (2004). The Global Burden of Typhoid Fever. Bulletin of the World Health Organization, May 2004, 82(5). Available at: www.who.int/rpc/TFDisBurden.pdf

Harvey, P. (2007). Well Factsheet: Field Water Quality Testing in Emergencies. Water, Engineering and Development Centre, Loughborough University, United Kingdom. Available at: www.lboro.ac.uk/well/resources/fact-sheets/fact-sheets-htm/WQ%20in%20emergencies.htm

Kappus, K., Lundgren, R., Jr., Juranek, D., Roberts, J. and H. Spencer (1994). Intestinal Parasitism in the United States: Update on a Continuing Problem. Am J Trop Med Hyg. 1994;50(6):705-13. Cited in Centers for Disease Control and Prevention (2011). Parasites – Giardia. Available at: www.cdc.gov/parasites/giardia/

Médecins Sans Frontières (1994). Public Health Engineering in Emergency Situations. MSF, Paris.

Prüss-Üstün, A., Bos, R., Gore, F. and J. Bartram (2008). Safer Water, Better Health: Costs, Benefits and Sustainability of Interventions to Protect and Promote Health. World Health Organization, Geneva, Switzerland. Available at: http://whqlibdoc.who.int/publications/2008/9789241596435_eng.pdf

South African Bureau of Standards (2001). South African National Standard 241: Standard Specification for Water for Domestic Supplies. Pretoria: Standards South Africa.

UNICEF (2008). UNICEF Handbook on Water Quality. UNICEF, New York, USA. Available at: www.unicef.org/wash/files/WQ_Handbook_final_signed_16_April_2008.pdf

UNICEF Canada (2013). Children dying daily because of unsafe water supplies and poor sanitation and hygiene, UNICEF says. Available at: www.unicef.ca/en/press-release/children-dying-daily-because-of-unsafe-water-supplies-and-poor-sanitation-and-hygiene-

WHO and UNICEF (2005). Water for Life: Making it Happen. WHO/UNICEF Joint Monitoring Programme for Water Supply and Sanitation. WHO, Geneva, Switzerland. Available at: www.wssinfo.org/fileadmin/user_upload/resources/1198249448-JMP_05_en.pdf

World Health Organization (1997). Guideline for Drinking Water Quality 2nd Edition, Volume 3, Surveillance and Control of Community Supplies, Geneva. Available at: www.who.int/water_sanitation_health/dwq/gdwg2v1/en/index2.html

World Health Organization (2002). Evaluation of the H₂S Method for Detection of Fecal Contamination of Drinking Water. Prepared by M. Sobsey and F. Pfaender, Department of Environmental Sciences and Engineering, School of Public Health, University of North Carolina, USA. Available at: www.who.int/water_sanitation_health/dwq/WSH02.08.pdf

World Health Organization (2009a). Initiative for Vaccine Research: Typhoid Fever in Diarrhoeal Diseases. Available at: www.who.int/vaccine_research/diseases/diarrhoeal/en/index7.html

World Health Organization (2009b). Risk Assessment of Cryptosporidium in Drinking-Water. WHO, Geneva, Switzerland. Available at: http://whqlibdoc.who.int/hq/2009/WHO_HSE_WSH_09.04_eng.pdf

World Health Organization (2011). Guidelines for Drinking-Water Quality, Fourth Edition. WHO, Geneva, Switzerland. Available at: www.who.int/water_sanitation_health/dwq/secondaddendum20081119.pdf

World Health Organization (2012a). 10 Facts on Cholera. WHO, Geneva, Switzerland. Available at: www.who.int/features/factfiles/cholera/en/index.html

World Health Organization (2012b). Rapid Assessment of Drinking-Water Quality: A Handbook for Implementation. WHO, Geneva, Switzerland. Available at: www.who.int/water_sanitation_health/publications/2012/rapid_assessment/en/index.html

World Health Organization (2013a). Global Health Observatory: Number of Reported Cholera Cases. WHO, Geneva, Switzerland. Available at: www.who.int/gho/epidemic_diseases/cholera/cases_text/en/index.html

World Health Organization (2013b). Hepatitis A Fact Sheet N°328. WHO, Geneva, Switzerland. Available at: www.who.int/mediacentre/factsheets/fs328/en/

World Health Organization (2013c). Hepatitis E Fact Sheet N°280. WHO, Geneva, Switzerland. Available at: www.who.int/mediacentre/factsheets/fs280/en/

Introduction to Drinking Water Quality Testing

Section 8: Interpreting Test Results

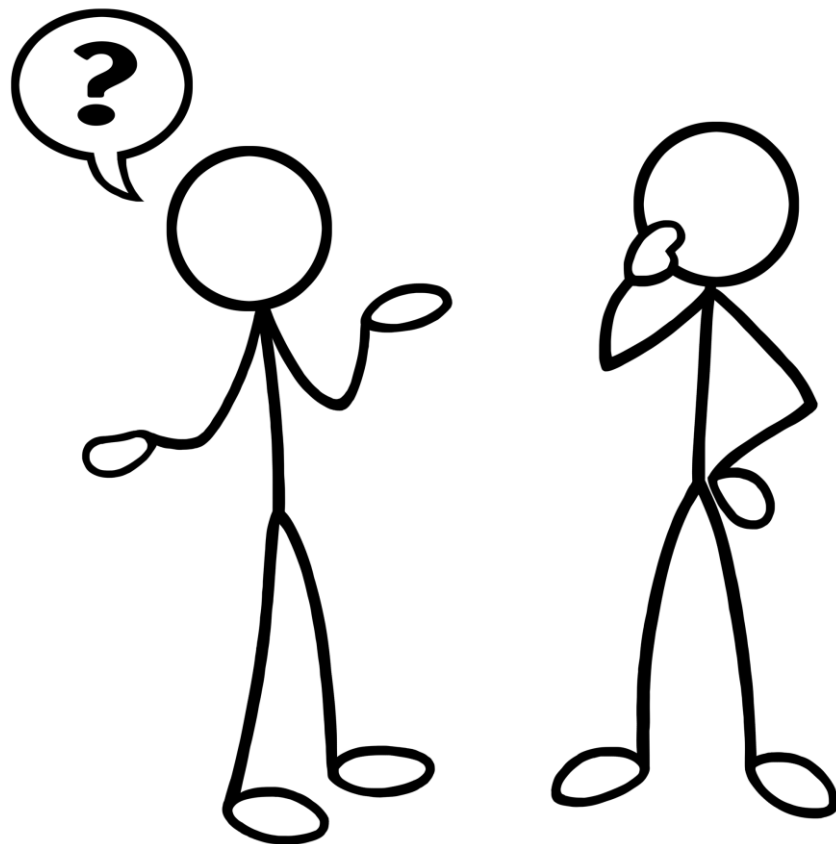

Table of Contents

Section 8: Interpreting Test Results.....	i
8.1 Introduction	1
8.2 Steps for Data Interpretation.....	2
8.2.1 Collect Data for Analysis.....	2
8.2.2 Check the Data Quality	3
8.2.3 Choose an Appropriate Analysis.....	3
8.2.4 Interpret Data in Relation to the Objectives	5
8.2.5 Report the Results	6
8.3 Interpreting Laboratory Reports	6
8.4 Summary of Key Information	9
8.5 References	9

8.1 Introduction

Data interpretation allows you to learn from the water quality test results, helps you improve your sampling program, and is really the reason you collected the data in the first place. You will need to take a good look at the results and try to understand them to develop your final conclusions and recommendations. Besides providing a report of the analysis for given contaminants, most commercial laboratories or portable test kits provide little explanation of the test results. The information provided in this section will help you understand and interpret your water quality testing results.

Although we have separated physical, chemical and microbiological testing, it is useful to compare the results to determine any correlations.

There are three main approaches for interpreting the results from water quality tests which are discussed in the following sections:

1. The results can be compared to national water quality standards or the World Health Organization (WHO) Guidelines for Drinking Water Quality.
2. The results can be reviewed to see how they change over time and location to identify any trends or correlations.
3. Statistical analysis can be done for academic purposes and scientific research.

8.2 Steps for Data Interpretation

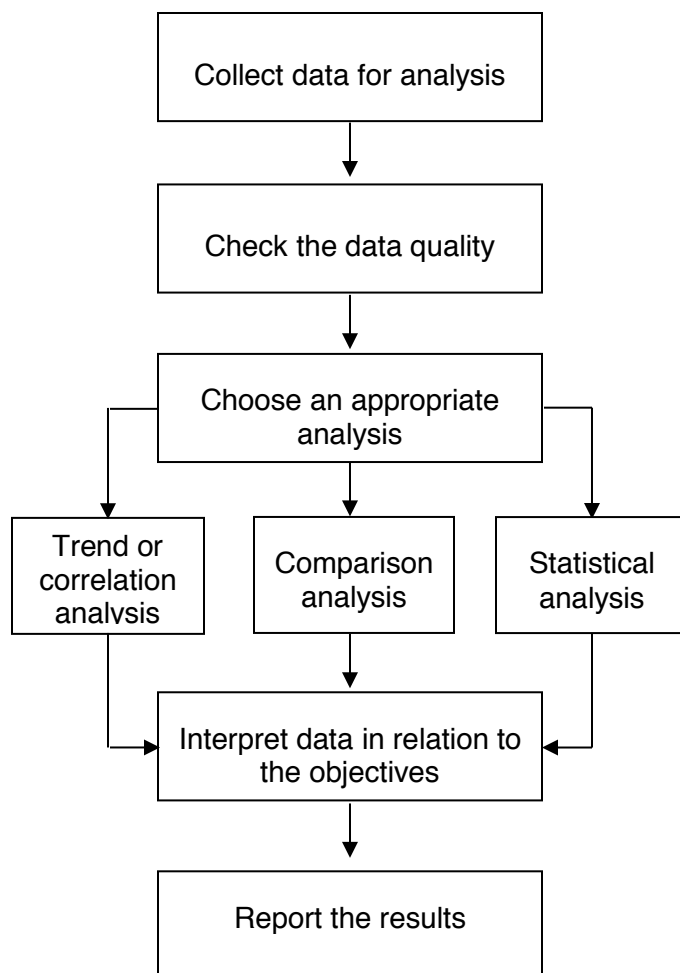

- Enter the data in an appropriate table, spreadsheet or database.
- Address any unusual results. For example, if the number of *E. coli* is higher in the treated water compared to source water, it would be good to retake samples on different days and times.
- Data analysis methods should be selected in advance, and there should be enough data to analyze (see selecting sample size in Section 2: Planning).
- Results should be recorded in a simple format and easy for the audience to understand.
- Interpret the results so they are meaningful to the project objectives and situation in the local context. When generating results, keep in mind the quality control and reliability of the testing process.
- Develop conclusions and recommendations. Report the results.

(Adapted from CCME, 2006)

8.2.1 Collect Data for Analysis

Data recording forms are used to document your water samples and test results. See Appendix 6 for example data recording forms. These forms can be adapted to meet the specific needs of your project.

Many forms may be used, depending on how many samples are taken and the number of tests performed, so it is important to choose the correct forms for data entry.

It is also important to collect all of data recording forms each day while water is being sampled and tested. This helps to ensure that the forms are not misplaced or lost, and that the data is entered into a table, spreadsheet, or database as soon as possible.

8.2.2 Check the Data Quality

The data record forms need to be checked thoroughly to ensure that all information was recorded clearly, correctly, and completely. If any data is missing or incomplete, another sample should be taken and/or the test should be repeated to get correct and complete information. Common errors in recording data include the following:

- Using wrong units (e.g., writing ppb instead of ppm)
- Writing is not clear
- Missing or incomplete data
- Putting the decimal in the wrong place
- Recording data for the wrong sample
- Recording the result in the wrong place

If data is incorrect or missing or if there are any unusual test results, another sample should be taken and the test should be repeated to get correct and complete data. If there continues to be unusual results then there may be problems with equipment calibration, expired test strips or culture media, or secondary contamination. Refer to Section 4: Water Sampling and Quality Control which explains how to reduce such errors.

8.2.3 Choose an Appropriate Analysis

There are three main approaches for analyzing the results from water quality tests:

1. Comparison analysis
2. Trend and correlation analysis
3. Statistical analysis

Comparison Analysis

A comparison analysis is usually carried out to determine the existing situation compared with national standards or WHO guidelines. This type of analysis can also be useful to compare the water quality or effectiveness of water treatment between different locations or user groups, such as high, medium and low-income households.

Trend and Correlation Analysis

Trend analysis shows how a physical, chemical or microbiological parameter changes with time and location. Graphing is an excellent way to display your data, and is very helpful when you are analyzing trends and correlations. There are many kinds of graphs, and you are encouraged to find different ways of looking at data.

Time-history graphs can illustrate changes in water quality over a period of time (i.e., in hours, days, months, or years). For example, the following line graph shows that average *E. coli* levels for a particular water source were gradually decreasing until May and then started increasing from August onward.

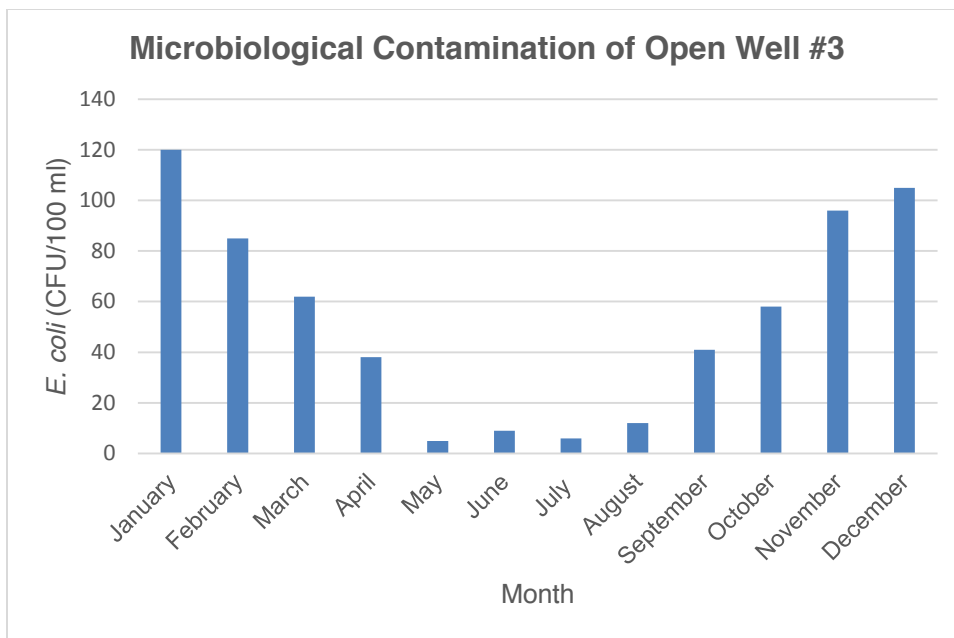

A spatial graph can be used to show how water quality varies according to the sampling locations. The following bar graph shows that the water from the source and transfer bucket both have *E. coli* contamination, but the transfer bucket water has higher levels, probably due to secondary contamination. The filtered water is good in terms of water quality; however, the results show that there is a recontamination problem in the storage water.

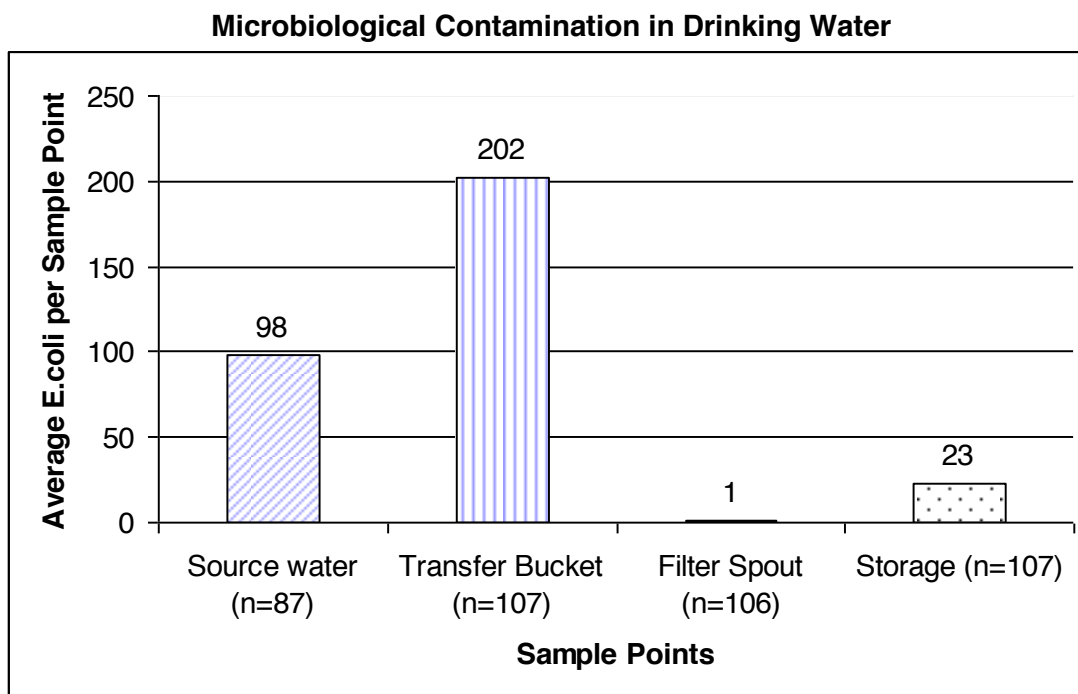

(Credit: Baker and Duke, 2006)

Statistical Analysis

Statistical analysis can be done for academic purposes and scientific research. Computer software is available to process numerical data and perform statistical tests. Spreadsheets, such as Microsoft Excel, also have powerful graphical and statistical capability.

Statistical analysis for more rigorous research is outside the scope of this Manual. However, CAWST can refer you to additional resources for conducting statistical analysis of your water testing results. Please contact us at: resources@kawst.org.

8.2.4 Interpret Data in Relation to the Objectives

The objectives of the overall project and the water quality testing program need to be kept in mind when you are interpreting your test results. Different objectives can result in a different interpretation of the same test data. As discussed in Section 2: Planning for Drinking Water Quality Testing, the following are some examples of objectives for water quality testing:

- Identify an appropriate drinking water source
- Identify the source of an outbreak of a drinking water-related disease
- Investigate seasonal changes in drinking water quality
- Increase user awareness on water quality issues
- Assess the effectiveness of household water treatment and safe storage (HWTS) in reducing turbidity and pathogens
- Assess the concentration of arsenic and fluoride in drinking water
- Provide troubleshooting as part of an ongoing monitoring program
- Monitor compliance with standards or guidelines
- Evaluate the effectiveness of a safe water project

Project implementers often carry out water quality testing to bring awareness in the community about the difference between contaminated water and treated water (for example, using a simple presence-absence test to indicate microbiological contamination). In such situations, results may be presented immediately to the community without complete interpretation of the overall data. This situation can sometimes go wrong if you generate a negative test result in front of the community without the ability to explain the result or perform any quality control to verify the test. This can easily create a negative impression about the project implementation and should be avoided if possible. If it is necessary to distribute early results, it is important to emphasize that they are incomplete and full results will be available after the data has been interpreted.



How to Calculate the % Removal Effectiveness of Water Treatment

$$\frac{\text{Source water } E. coli \text{ colony count} - \text{Treated water } E. coli \text{ colony count}}{\text{Source water } E. coli \text{ colony count}} \times 100 = \% \text{ Removal Effectiveness}$$

This same formula can also be used to calculate the treatment removal effectiveness of physical (e.g., turbidity) or chemical parameters (e.g., arsenic, fluoride) from drinking water.

8.2.5 Report the Results

The primary purpose of a report is to share your results, conclusions, and recommendations to an audience. This information should be assembled in a well-organized and easy to read format. It is particularly important to include graphs and tables to help make the report easy to understand.

Reports should be made as early as possible so that corrective actions can be taken to ensure safe drinking water. It is also important to share the results with the users and/or community so that they are aware of their drinking water quality and understand if corrective actions need to be taken. Reporting the results also gives feedback to improve the project implementation.

Appendix 7 gives an example of a water quality testing report.



As drinking water quality is a sensitive topic, simply providing the test results without guidance and interpretation could lead to misinterpretations and inappropriate action or inaction (especially if the report is disseminated outside of the organization). Water quality testing can be a great awareness raising and mobilization tool as long as the results are interpreted and presented properly.

8.3 Interpreting Laboratory Reports

If you send your water to a commercial laboratory for testing, they will send you a report with the results. Most laboratories provide little additional explanation of test results beyond the units used or possibly a footnote in the event that a problem is identified.

A laboratory report will normally contain a table of physical, chemical, and microbiological parameters for which your sample was tested, and the measured concentration of each. If you have any problems understanding the way information is presented in the report, then you should contact the laboratory directly for an explanation.

The following are two example reports which show how different laboratories will use different formats for reporting test results.

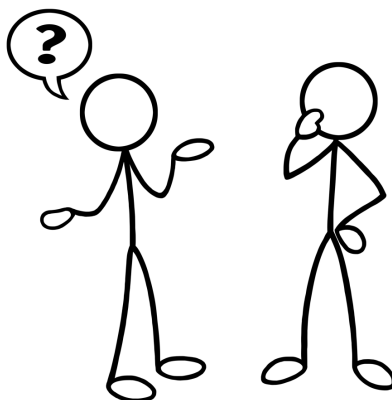



P.O. Box 250107, Ndola, Zambia;
Plot 384 Makoli Avenue, Town Center
Ndola, Zambia

Cellular: +26 0976 173020 / +26 0955 992826 / +26 0967 605730 — Tele-Fax +26 0212 680143
E-mail: shipzambia@gmail.com; Website: www.sohip.org

AFMAC WATER ANALYSIS REPORT

Ref No.....025497

ORGANISATION: FOUNDATION FOR AFRICA

LOCATION:

SOURCE TYPE / SAMPLE DISCRIPTION: BOREHOLE WITH HAND PUMP & TANK

DATE SAMPLED: 2012-11-14

DATE TESTED: 2012-11-14 &15

PARAMETER	UNIT	Hand pump Mark 11	Water Tank Via Tap	Zambian Standard (Maximum Permissible Limit)	WHO Guidelines
E.coli	CFU/100 ml	102*	138*	0	0
pH		7.13	7.20	6.5-8.0	
Turbidity	NTU	2.14	1.32	10	<5
Iron	mg/l	0.07	0.09	1.0	0.3
Phosphate	mg/l	0.98	0.70		
Fluoride	mg/l	0.20	0.01	1.5	1.5
Nitrate	mg/l	19.8	21.2	10	50
Nitrite	mg/l	0.23	0.25	1.0	3
HardnessCaCO ₃	mg/l	198	130	500	
Manganese	mg/l	0.005	0.005	0.1	0.5
Chloride	mg/l	75	75	600	
Copper	mg/l	1.55	1.55	1.0	2.0

*outside Limit/Guideline

COMMENT : The quality of the water indicates faecal contamination . Chlorination of the borehole is recommended after which repeat sampling and testing should be conducted. Household water treatment is recommended .

E. BANDA _____ DATE...2012-11-15
Lab Manager

Cc Director SHIP Zambia
Program Manager AFMAC
File #

(Credit: Seeds of Hope International Partnerships, 2012)

Northeast Environmental Laboratory, Inc.					
18 Riverside Avenue, Danvers, MA 01923					
978-777-4442 DEP #MA123					
A. Customer			Report Number	28741	
Boxford, MA 01921			Report Date	4/25/08	
68635 Kitchen Tap			Preservation 4°C, HNO3		
Collected 4/10/08 at 10:00 by AC					
Received 4/10/08 at 12:00 by DE					
Test Performed	Result	MMCL, MA maximum contaminant level SMCL, Secondary maximum contaminant level Recommended	Analyzed	Method	
Alkalinity	80	mg/L 30-100	4/10/08	2320B	
Arsenic	0.011	mg/L 0.01 maximum	4/18/08	3113B	
Calcium	31.9	mg/L 50-150	4/18/08	3111B	
Chloride	40.5	mg/L SMCL 250	4/11/08	300.0	
Conductivity	338	µS/cm	4/10/08	2510B	
Fluoride	0.45	mg/L SMCL 2.0	4/11/08	300.0	
Hardness (as CaCO3)	113	mg/L 250 maximum	4/21/08	2340B	
Iron	4.97	mg/L SMCL 0.3	4/14/08	3111B	
Lead	0.002	mg/L MMCL 0.015	4/15/08	3113B	
Magnesium	8.18	mg/L	4/18/08	3111B	
Manganese	0.03	mg/L SMCL 0.05	4/17/08	3111B	
Nitrate	< 0.04	mg/L MMCL 10	4/11/08	300.0	
Nitrite	< 0.02	mg/L MMCL 1.0	4/11/08	300.0	
Orthophosphate (as P)	< 0.08	mg/L	4/11/08	300.0	
pH	7.86	s.u. SMCL 6.5-8.5	4/10/08	4500-HB	
Potassium	1.36	mg/L	4/21/08	3111B	
Sodium	17.2	mg/L 20 maximum	4/17/08	3111B	
Sulfate	19.3	mg/L SMCL 250	4/11/08	300.0	

This water appears to be slightly corrosive.

References
 Methods for the Determination of Inorganic Substances in Environmental Samples, EPA/600/R-93/100, August, 1993.
 Standard Methods for the Examination of Water and Wastewater, 19th edition, 1995.

Reviewed and Approved by:
 John Lovatt
 Laboratory Director

(Credit: Northeast Environmental Laboratory Inc.)

8.4 Summary of Key Information

- There are three main approaches for interpreting the results from water quality tests:
 1. The measured values of physical, chemical and microbiological parameters can be compared to national water quality standards or the WHO Guidelines for Drinking Water Quality.
 2. The results can be reviewed to see how they change over time and location to identify any trends or correlations.
 3. Statistical analysis can be done for academic purposes and scientific research.
- The following are the general steps for data interpretation:
 1. Collect data for analysis
 2. Check the data quality
 3. Choose an appropriate analysis
 4. Interpret data in relation to the objectives
 5. Report the results
- The primary purpose of a report is to share your results, conclusions, and recommendations to an audience. This information should be assembled in a well-organized and easy to read format. It is particularly important to include graphs and tables to help make the report easy to understand.
- If you send your water to a commercial laboratory for testing, they will send you a report with the results. Most laboratories provide little additional explanation of test results beyond the units used or possibly a footnote in the event that a problem is identified.
- A laboratory report will normally contain a table of physical, chemical, and microbiological parameters for which your sample was tested, and the measured concentration of each. If you have any problems understanding the way information is presented in the report, then you should contact the laboratory directly for an explanation.

8.5 References

Baker D.L. and W. F. Duke (2006). Intermittent Slow Sand Filters for Household Use - A Field Study in Haiti, IWA Publishing, London, UK. Available at:

www.cawst.org/en/resources/pubs/research-a-technical-updates/category/7-peer-reviewed-research

Canadian Council of Ministers of the Environment (2006). A Canada-wide Framework for Water Quality Monitoring. Water Quality Task Group, CCME, Canada. Available at:

www.ccme.ca/assets/pdf/wqm_framework_1.0_e_web.pdf

Seeds of Hope International Partnerships (2012). AFMAC Water Analysis Report. Ndola, Zambia.

Introduction to Drinking Water Quality Testing

Appendix 1: Sanitary Inspection Forms

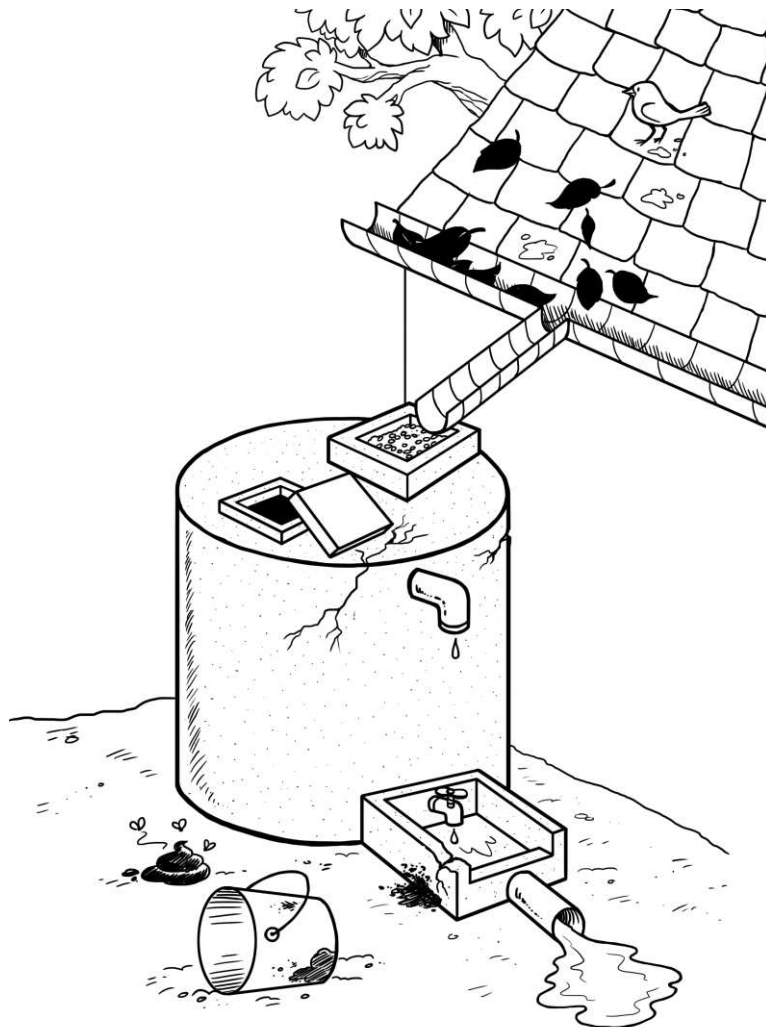

Sanitary Inspection Form: Borehole with Hand Pump

Part 1. General information:

- a. Location:
- b. Village/Town:
- c. People served:
- d. Water sample taken? Sample ID
- e. Date of visit:

Part 2. Risk assessment: Circle the most appropriate answer. A 'Yes' answer means that there is a potential risk and a 'No' answer that there is no or very low risk. See explanation on reverse.

	Observation
1. Is there a latrine within 10 m of the borehole?	Y/N
2. Is there a latrine or other source of fecal contamination uphill of the borehole?	Y/N
3. Is there any source of other contamination within 10 m of the borehole (e.g., animals, agriculture, roads, industry, etc.)?	Y/N
4. Is the drainage absent or faulty allowing water to pool within 2 m of the borehole?	Y/N
5. Is the drainage channel absent, cracked, broken or in need of cleaning?	Y/N
6. Is the wall or fence around the pump inadequate?	Y/N
7. Is the well apron less than 2 m in diameter?	Y/N
8. Does spilt water collect in the apron area?	Y/N
9. Is the well apron or pump cover cracked or damaged?	Y/N
10. Is the hand pump loose at the point of attachment? For rope-washer pumps, is the pump cover missing?	Y/N

Risk of contamination (add the number of 'Yes' answers):/10

Part 3. Results and comments:

a. Risk of contamination (check the appropriate box):

9-10 = Very high	6-8 = High	3-5 = Medium	0-2 = Low

b. The following risks were observed:

Part 4. Name and signature of inspectors:



Explanatory Notes: Borehole with Hand Pump

1. *Is there a latrine within 10 m of the borehole?* Latrines close to groundwater supplies may affect water quality (e.g., by infiltration). You may need to visually check structures to see if they are latrines in addition to asking household members.

2. *Is there a latrine or other source of fecal contamination uphill of the borehole?* Contamination on higher ground poses a risk, especially in the wet season, as feces (and other contaminants) may flow into the water source. The risk is increased if no surface water diversion is present. Groundwater may also flow towards the borehole from the direction of the latrine.

3. *Is there any source of other contamination within 10 m of the borehole (e.g., animals, agriculture, roads, industry, etc.)?* Animal or human feces close to the borehole are a serious risk to water quality, especially when water diversion ditches are not present. Open disposal of other waste (e.g., household, agricultural) is also a risk to water quality.

4. *Is the drainage absent or faulty allowing water to pool within 2 m of the borehole?* If pools of water collect around the borehole they may provide a way for contaminants to enter the source.

5. *Is the drainage channel absent, cracked, broken or in need of cleaning?* Poor construction or maintenance of the drainage channel, leading to cracks or breaks, is a high risk to water quality, especially when combined with water spillage and poor sanitary conditions.

6. *Is the wall or fence around the pump inadequate?* If there is no fence or the fence is damaged, then animals can access the borehole and may damage the structure as well as contaminate the area with feces. You will need to check the fencing at the site as well as check whether animals are routinely in the area (sometimes animals are kept in the fenced area for security).

7. *Is the well apron less than 2 m in diameter?* The apron (also known as the platform or slab) is built to prevent backflow of water into the borehole. To do this adequately the apron needs to be at least 2 m in diameter.

8. *Does spilt water collect in the apron area?* If water does not drain away from the apron area, then water (possibly contaminated) could backflow into the water source.

9. *Is the well apron or pump cover cracked or damaged?* Cracks, especially deep ones, in the apron or pump cover may allow backflow into the water source.

10. *Is the hand pump loose at the point of attachment? For rope-washer pumps, is the pump cover missing?* A loose hand pump or missing pump cover may allow backflow of contaminated water into the water source.

Sanitary Inspection Form adapted from:

World Health Organization (2012). Rapid Assessment of Drinking-Water Quality: A Handbook for Implementation. WHO, Geneva, Switzerland. Available at: www.who.int/water_sanitation_health/publications/2012/rapid_assessment/en/index.html

World Health Organization (2005). Water Safety Plans: Managing Drinking-Water Quality from Catchment to Consumer. WHO, Geneva Switzerland. Available at: www.who.int/water_sanitation_health/dwq/wsp0506/en/index.html

World Health Organization (1997). Guidelines for Drinking Water Quality, Second Edition, Volume 3, Surveillance and Control of Community Supplies. WHO, Geneva, Switzerland. Available at: www.who.int/water_sanitation_health/dwq/gdwq2v1/en/index2.html



Illustration of Borehole with Hand Pump

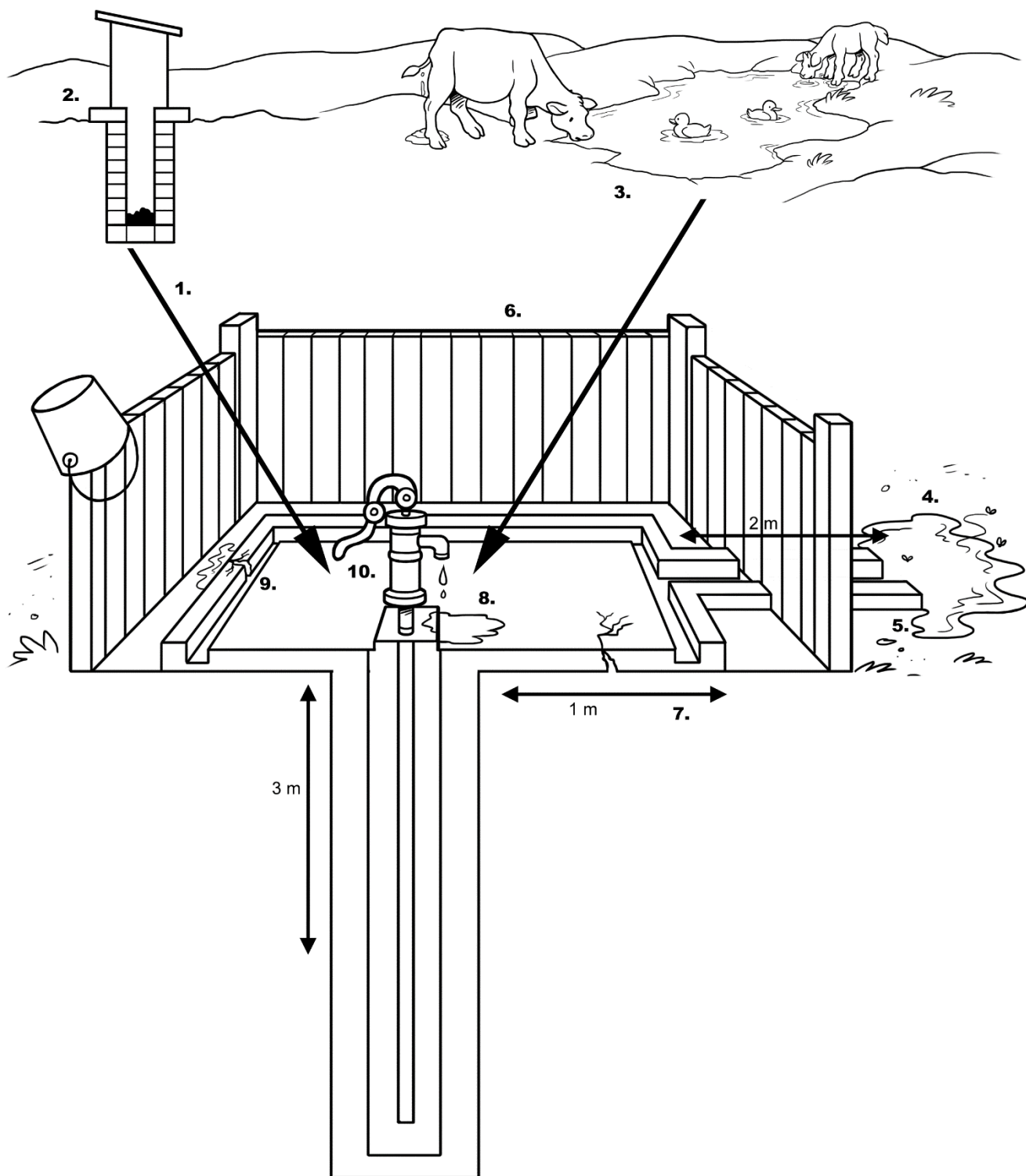

Sanitary Inspection Form: Borehole with Mechanized Pump

Part 1. General information:

- a. Location:
- b. Village/Town:
- c. People served:
- d. Water sample taken? Sample ID
- e. Date of visit:

Part 2. Risk assessment: Circle the most appropriate answer. A 'Yes' answer means that there is a potential risk and a 'No' answer that there is no or very low risk. See explanation on reverse.

	Observation
1. Is there a latrine or sewer within 100 m of the pump?	Y/N
2. Is there a latrine within 10 m of the borehole?	Y/N
3. Is there any source of other contamination within 50 m of the borehole (e.g., animals, agriculture, roads, industry)?	Y/N
4. Is there an uncapped well within 100 m?	Y/N
5. Is the drainage channel absent, cracked, broken or in need of cleaning?	Y/N
6. Can animals come within 50 m of the borehole?	Y/N
7. Is the base of the pumping mechanism permeable to water?	Y/N
8. Is there stagnant water within 2 m of the pump?	Y/N
9. Is the well seal dirty?	Y/N
10. Is the borehole cap cracked?	Y/N

Risk of contamination (add the number of 'Yes' answers):/10

Part 3. Results and comments:

a. Risk of contamination (check the appropriate box):

9-10 = Very high	6-8 = High	3-5 = Medium	0-2 = Low

b. The following risks were observed:

Part 4. Name and signature of inspectors:



Explanatory Notes: Borehole with Mechanized Pump

1. *Is there a latrine or sewer within 100 m of the pump?* Any leaks from the sewer or latrine could contaminate the borehole water by draw down caused by pumping. You can observe latrines and check with household members, but you may need to ask relevant professionals about the location of sewers.

2. *Is there a latrine within 10 m of the borehole?* Latrines close to groundwater supplies may contaminate the water quality (e.g., by infiltration). You may need to visually check structures to see if they are latrines in addition to asking household members.

3. *Is there any source of other contamination within 50 m of the borehole (e.g., animals, agriculture, roads, industry)?* Animal or human feces close to the borehole are a serious risk to water quality, especially when there are no water diversion ditches. Open disposal of other waste (e.g., household, agricultural etc.) is also a risk to water quality.

4. *Is there an uncapped well within 100 m?* Uncapped wells can be easily contaminated and the pollution can spread through the groundwater. You can check visually for such wells and also ask household members.

5. *Is the drainage channel absent, cracked, broken or in need of cleaning?* Poor construction or maintenance of the drainage channel (leading to cracks or breaks) is a high risk to water quality, especially when combined with water spillage and poor sanitary conditions.

6. *Can animals come within 50 m of the borehole?* If there is no fence or the fence is damaged, then animals can access the borehole and may damage the structure as well as pollute the area with feces. You will need to check the fencing at the site as well as check whether animals are routinely in the area (sometimes animals are kept in the fenced area for security).

7. *Is the base of the pumping mechanism permeable to water?* If the base is permeable (e.g., there is no cover or the cover has deep cracks), then surface water run-off could provide a way for contamination to enter the ground water.

8. *Is there stagnant water within 2 m of the pump?* Pools of water that collect around the pump may provide a way for contaminants to enter the water source.

9. *Is the well seal dirty?* Feces, garbage and other waste around the well seal are a risk to the water quality.

10. *Is the borehole cap cracked?* Cracks allow contaminants to enter the borehole and are a risk to water quality.

Sanitary Inspection Form adapted from:

World Health Organization (2012). Rapid Assessment of Drinking-Water Quality: A Handbook for Implementation. WHO, Geneva, Switzerland. Available at: www.who.int/water_sanitation_health/publications/2012/rapid_assessment/en/index.html

World Health Organization (2005). Water Safety Plans: Managing Drinking-Water Quality from Catchment to Consumer. WHO, Geneva Switzerland. Available at: www.who.int/water_sanitation_health/dwq/wsp0506/en/index.html

World Health Organization (1997). Guidelines for Drinking Water Quality, Second Edition, Volume 3, Surveillance and Control of Community Supplies. WHO, Geneva, Switzerland. Available at: www.who.int/water_sanitation_health/dwq/gdwq2v1/en/index2.html



Sanitary Inspection Form: Dug Well with Hand Pump

Part 1. General information:

- a. Location:
- b. Village/Town:
- c. People served:
- d. Water sample taken? Sample ID
- e. Date of visit:

Part 2. Risk assessment: Circle the most appropriate answer. A 'Yes' answer means that there is a potential risk and a 'No' answer that there is no or very low risk. See explanation on reverse.

	Observation
1. Is there a latrine within 10 m of the well?	Y/N
2. Is there a latrine or other source of fecal contamination uphill of the well?	Y/N
3. Is there any source of other contamination within 10 m of the well (e.g., animals, agriculture, cultivation, roads, industry)?	Y/N
4. Is the drainage absent or faulty allowing water to pool within 3 m of the well?	Y/N
5. Is the drainage channel absent or cracked, broken or in need of cleaning?	Y/N
6. Is the apron less than 2 m in diameter around the top of the well?	Y/N
7. Does spilt water collect in the apron area?	Y/N
8. Is the well apron cracked or damaged?	Y/N
9. Is the hand pump loose at the point of attachment? For rope-washer pumps, is the pump cover missing?	Y/N
10. Is the well cover absent or dirty?	Y/N

Risk of contamination (add the number of 'Yes' answers):/10

Part 3. Results and comments:

a. Risk of contamination (check the appropriate box):

9-10 = Very high	6-8 = High	3-5 = Medium	0-2 = Low

b. The following risks were observed:

Part 4. Name and signature of inspectors:



Explanatory Notes: Dug Well with Hand Pump

- 1. Is there a latrine within 10 m of the well?* Latrines close to groundwater supplies may affect water quality (e.g. by infiltration). You may need to visually check structures to see if they are latrines in addition to asking residents.
- 2. Is there a latrine or other source of fecal contamination uphill of the well?* Contamination on higher ground poses a risk, especially in the wet season, as feces (and other contaminants) may flow into the water source. The risk is increased if no surface water diversion is present. Groundwater may also flow towards the borehole from the direction of the latrine.
- 3. Is there any source of other contamination within 10 m of the well (e.g. animals, agriculture, roads, industry)?* Animal or human feces close to the borehole are a serious risk to water quality, especially when water diversion ditches are not present. Open disposal of other waste (e.g., household, agricultural) is also a risk to water quality.
- 4. Is the drainage absent or faulty allowing water to pool within 3 m of the well?* If pools of water collect around the borehole, then they may provide a route for contaminants to enter the water source.
- 5. Is the drainage channel absent or cracked, broken or in need of cleaning?* Poor construction or maintenance of the drainage channel, leading to cracks and breaks, especially when combined with spillage of water and poor sanitary conditions, poses a high risk to water quality.
- 6. Is the apron less than 2 m in diameter around the top of the well?* The apron (also known as the platform or slab) is built to prevent backflow of water into the borehole. To do this adequately the apron needs to be at least 2 m in diameter.
- 7. Does spilt water collect in the apron area?* If water does not drain away from the apron area, then water (possibly contaminated) could backflow into the water source.
- 8. Is the well apron cracked or damaged?* Cracks, especially deep ones, in the concrete may allow backflow into the water source.
- 9. Is the hand pump loose at the point of attachment? For rope-washer pumps, is the pump cover missing?* A loose hand pump or missing pump cover may allow backflow of contaminated water into the water source.
- 10. Is the well cover absent or dirty?* Absence of a cover or a dirty cover increases the chances of contamination entering the well.

Sanitary Inspection Form adapted from:

World Health Organization (2012). Rapid Assessment of Drinking-Water Quality: A Handbook for Implementation. WHO, Geneva, Switzerland. Available at: www.who.int/water_sanitation_health/publications/2012/rapid_assessment/en/index.html

World Health Organization (2005). Water Safety Plans: Managing Drinking-Water Quality from Catchment to Consumer. WHO, Geneva Switzerland. Available at: www.who.int/water_sanitation_health/dwq/wsp0506/en/index.html

World Health Organization (1997). Guidelines for Drinking Water Quality, Second Edition, Volume 3, Surveillance and Control of Community Supplies. WHO, Geneva, Switzerland. Available at: www.who.int/water_sanitation_health/dwq/gdwq2v1/en/index2.html



Sanitary Inspection Form: Household Piped Water

Part 1. General information:

- a. Household:.....
- b. Source of water:
- c. Village/Town:
- d. Water sample taken? Sample ID
- e. Date of visit:

Part 2. Risk assessment: Circle the most appropriate answer. A 'Yes' answer means that there is a potential risk and a 'No' answer that there is no or very low risk. See explanation on reverse.

	Observation
1. Is the tap outside the house (e.g. in the yard)?	Y/N
2. Is the water stored in a container inside the house?	Y/N
3. Is the storage tank or any of the taps leaking or damaged?	Y/N
4. Are any taps shared with other households?	Y/N
5. Is the area around the tank or tap dirty?	Y/N
6. Are there any leaks in the household pipes?	Y/N
7. Do animals have access to the area around the pipe?	Y/N
8. Have users reported pipe breaks in the last week?	Y/N
9. Has there been a disruption in the water supply in the last 10 days?	Y/N
10. Does the household water come from more than one source?	Y/N

Risk of contamination (add the number of 'Yes' answers):/10

Part 3. Results and comments:

a. Risk of contamination (check the appropriate box):

9-10 = Very high	6-8 = High	3-5 = Medium	0-2 = Low

b. Does the distribution system deliver water directly to a storage tank (usually on the roof)?

c. The following risks were observed:

Part 4. Name and signature of inspectors:



Explanatory Notes: Household Piped Water

1. *Is the tap outside the house (e.g., in the yard)?* Taps in yards may be more prone to damage, especially if animals have access to the yard (see question 7). The cleanliness of the yard could also be a risk to water quality (see question 5).
2. *Is the water stored in a container inside the house?* There is the risk of contamination during and after collection from the tap, for example, from dirty hands or from using a dirty container (see Sanitary Inspection Form for Household Containers).
3. *Is the storage tank or any of the taps leaking or damaged?* If the storage tank or taps are leaking or damaged, then cracks may be a route for contaminants to enter the pipes. You will need to see if water is leaking from the taps or if it is only spilt water. If water from the distribution system goes directly to a storage tank (usually located on the roof), then record this in Part 3 of the form.
4. *Are any taps shared with other households?* Shared taps may not be well maintained since no one has independent ownership and, therefore, responsibility.
5. *Is the area around the tank or tap dirty?* Feces, garbage and other waste are a risk to water quality.
6. *Are there any leaks in the household pipes?* You will need to observe visible pipes and check with household members about other possible leaks.
7. *Do animals have access to the area around the pipes or taps?* If animals can access the pipes or taps, then they may cause damage to the structures as well as contaminate the area with feces. You will need to check whether animals are routinely in the area by asking household members and by visually checking for signs of animals and feces.
8. *Have users reported pipe breaks in the last week?* Pipe breaks (or major leaks) are a risk to water quality as contaminants can enter the system through the break. You will need to ask household members about any pipe breaks. You could also check whether the system was disinfected after the last break was fixed.
9. *Has there been a disruption in water supply in the last 10 days?* During disruptions the distribution pipes become empty and pressure differences may lead to water (and silt) from the soil entering the pipes. The soil may be contaminated and is a risk to water quality. You will need to ask household members about disruptions (record the frequency and duration if this is possible).
10. *Does the household water come from more than one source?* Different water sources may have different qualities and may not all be “improved” or “safe”. This may be a seasonal occurrence, affected by factors such as availability of sources or the length of queues at water points. You will need to ask household members about their use of single or different sources of water (in different seasons or during disruptions).

Sanitary Inspection Form adapted from:

World Health Organization (2012). Rapid Assessment of Drinking-Water Quality: A Handbook for Implementation. WHO, Geneva, Switzerland. Available at: www.who.int/water_sanitation_health/publications/2012/rapid_assessment/en/index.html

World Health Organization (2005). Water Safety Plans: Managing Drinking-Water Quality from Catchment to Consumer. WHO, Geneva Switzerland. Available at: www.who.int/water_sanitation_health/dwg/wsp0506/en/index.html

World Health Organization (1997). Guidelines for Drinking Water Quality, Second Edition, Volume 3, Surveillance and Control of Community Supplies. WHO, Geneva, Switzerland. Available at: www.who.int/water_sanitation_health/dwg/qdwg2v1/en/index2.html



Sanitary Inspection Form: Household Water Storage Container

Part 1. General information:

- a. Household:.....
- b. Source of water:
- c. Village/Town:
- d. Water sample taken? Sample ID
- e. Date of visit:

Part 2. Risk assessment: Circle the most appropriate answer. A 'Yes' answer means that there is a potential risk and a 'No' answer that there is no or very low risk. See explanation on reverse.

Observation

- 1. Is the container used for storing any other liquid or material? Y/N
- 2. Is the container kept at ground level? Y/N
- 3. Is the container lid or cover missing or not in place? Y/N
- 4. Is the container cracked, leaking, or dirty? Y/N
- 5. Is the area around the container dirty? Y/N
- 6. Do animals have access to the area around the container? Y/N
- 7. Is the tap or utensil (e.g., cup, ladle) used to draw water from the container dirty? Y/N
- 8. Is the water from the container also used for washing or bathing? Y/N
- 9. Has there been a disruption in the water supply in the last 10 days? Y/N
- 10. Does the stored water come from more than one source? Y/N

Risk of contamination (add the number of 'Yes' answers):/10

Part 3. Results and comments:

a. Risk of contamination (check the appropriate box):

9-10 = Very high	6-8 = High	3-5 = Medium	0-2 = Low

b. The following risks were observed:

Part 4. Name and signature of inspectors:



Explanatory Notes: Household Water Storage Container

- 1. Is the container used for storing any other liquid or material?* Other liquids or materials in contact with the container may be contaminated and be a risk to water quality. You will need to visually check the container for evidence of storing other liquids or materials, and also ask household members.
- 2. Is the container kept at ground level?* Keeping the container on the ground is a risk to water quality, especially when sanitation and hygiene practices are poor in the home. You can visually check the location of the container.
- 3. Is the container lid or cover missing or not in place?* Water stored in uncovered containers can be easily contaminated. You can visually check for the lid or cover, and also ask household members.
- 4. Is the container cracked, leaking or dirty?* A damaged container may be a route for contaminants to get into the water. You will need to see if water is from leaking from the container or if it is only spilt water. A dirty container is also a risk to water quality.
- 5. Is the area around the container dirty?* Feces, garbage, and other waste are a risk to the water quality.
- 6. Do animals have access to the area around the container?* Animals can contaminate the area or the container with feces. You will need to check whether animals are routinely in the area by asking household members and by visually checking for signs of animals and feces.
- 7. Is the tap or utensil (e.g., cup, ladle) used to draw water from the container dirty?* If the tap is dirty or, if there is no tap, then the utensil used to collect water may be dirty and contamination can be introduced to the container this way.
- 8. Is the water from the container also used for washing or bathing?* Water may be contaminated (e.g., by dirty hands) during collection for washing or bathing.
- 9. Has there been a disruption in the water supply in the last 10 days?* During disruptions the distribution pipes become empty and pressure differences may lead to water (and silt) from the soil entering the pipes. The soil may be contaminated and is a risk to water quality. In addition, stored water may be collected from other sources, which may be “unimproved”. You will need to ask household members about disruptions (record the frequency and duration if this is possible).
- 10. Does the stored water come from more than one source?* Different water sources may have different qualities and may not all be “improved” or “safe”. This may be a seasonal occurrence, affected by factors such as availability of sources or the length of queues at water points. You will need to ask household members about their use of single or different sources of water (in different seasons or during disruptions).

Sanitary Inspection Form adapted from:

World Health Organization (2012). Rapid Assessment of Drinking-Water Quality: A Handbook for Implementation. WHO, Geneva, Switzerland. Available at: www.who.int/water_sanitation_health/publications/2012/rapid_assessment/en/index.html

World Health Organization (2005). Water Safety Plans: Managing Drinking-Water Quality from Catchment to Consumer. WHO, Geneva Switzerland. Available at: www.who.int/water_sanitation_health/dwq/wsp0506/en/index.html

World Health Organization (1997). Guidelines for Drinking Water Quality, Second Edition, Volume 3, Surveillance and Control of Community Supplies. WHO, Geneva, Switzerland. Available at: www.who.int/water_sanitation_health/dwq/gdwq2v1/en/index2.html



Sanitary Inspection Form: Open Dug Well

Part 1. General information:

- a. Location:
- b. Village/Town:
- c. People served:
- d. Water sample taken? Sample ID
- e. Date of visit:

Part 2. Risk assessment: Circle the most appropriate answer. A 'Yes' answer means that there is a potential risk and a 'No' answer that there is no or very low risk. See explanation on reverse.

	Observation
1. Is there a latrine within 10 m of the well?	Y/N
2. Is there a latrine or other source of fecal contamination uphill of the well?	Y/N
3. Is there any source of other contamination within 10 m of the well (e.g., animals, agriculture, roads, industry, etc.)?	Y/N
4. Is the drainage absent or faulty allowing water to pool within 2 m of the well?	Y/N
5. Is the drainage channel absent or cracked, broken or in need of cleaning?	Y/N
6. Is the wall (parapet) around the top of the well inadequate, allowing surface water to enter the well?	Y/N
7. Is the well apron less than 2 m in diameter?	Y/N
8. Are the walls of the well inadequately sealed at any point for 3 m below ground?	Y/N
9. Is the well apron cracked or damaged?	Y/N
10. Are the rope and bucket left in such a position that they may become contaminated?	Y/N
11. Is the fence around the well inadequate?	Y/N

Risk of contamination (add the number of 'Yes' answers):/11

Part 3. Results and comments:

a. Risk of contamination (check the appropriate box):

9-11 = Very high	6-8 = High	3-5 = Medium	0-2 = Low

b. The following risks were observed:

Part 4. Name and signature of inspectors:



Explanatory Notes: Open Dug Well

1. *Is there a latrine within 10 m of the well?* Latrines close to groundwater supplies may affect water quality (e.g., by infiltration). You may need to visually check structures to see if they are latrines in addition to asking household members.
2. *Is there a latrine or other source of fecal contamination uphill of the well?* Contamination on higher ground poses a risk, especially in the wet season, as feces (and other contaminants) may flow into the water source. The risk is increased if no surface water diversion is present. Groundwater may also flow towards the well from the direction of the latrine.
3. *Is there any source of other contamination within 10 m of the well (e.g., animals, agriculture, roads, industry, etc.)?* Animal or human feces close to the borehole are a serious risk to water quality, especially when water diversion ditches are not present. Open disposal of other waste (e.g., household, agricultural) is also a risk to water quality.
4. *Is the drainage absent or faulty allowing water to pool within 2 m of the well?* If pools of water collect around the well they may provide a way for contaminants to enter the source.
5. *Is the drainage channel absent or cracked, broken or in need of cleaning?* Poor construction or maintenance of the drainage channel, leading to cracks or breaks, is a high risk to water quality, especially when combined with water spillage and poor sanitary conditions.
6. *Is the wall (parapet) around the top of the well inadequate, allowing surface water to enter the well? Surface water entering the well is usually contaminated and a high risk to water quality.*
7. *Is the well apron less than 2 m in diameter?* The apron (also known as the platform or slab) is built to prevent backflow of water into the well. To do this adequately the apron needs to be at least 2 m in diameter.
8. *Are the walls of the well inadequately sealed at any point for 3 m below ground?* Poorly constructed walls can allow contamination to infiltrate into the well water.
9. *Is the well apron cracked or damaged?* Cracks, especially deep ones, in the apron may allow backflow into the water source.
10. *Are the rope and bucket left in such a position that they may become contaminated?* A dirty rope and bucket can easily contaminate the well water.
11. *Is the fence around the well inadequate?* If there is no fence or the fence is damaged, then animals can access the well and may damage the structure as well as contaminate the area with feces. You will need to check the fencing at the site as well as check whether animals are routinely in the area (sometimes animals are kept in the fenced area for security).

Sanitary Inspection Form adapted from:

World Health Organization (2012). Rapid Assessment of Drinking-Water Quality: A Handbook for Implementation. WHO, Geneva, Switzerland. Available at: www.who.int/water_sanitation_health/publications/2012/rapid_assessment/en/index.html

World Health Organization (2005). Water Safety Plans: Managing Drinking-Water Quality from Catchment to Consumer. WHO, Geneva Switzerland. Available at: www.who.int/water_sanitation_health/dwg/wsp0506/en/index.html

World Health Organization (1997). Guidelines for Drinking Water Quality, Second Edition, Volume 3, Surveillance and Control of Community Supplies. WHO, Geneva, Switzerland. Available at: www.who.int/water_sanitation_health/dwg/gdwg2v1/en/index2.html



Illustration of an Open Dug Well

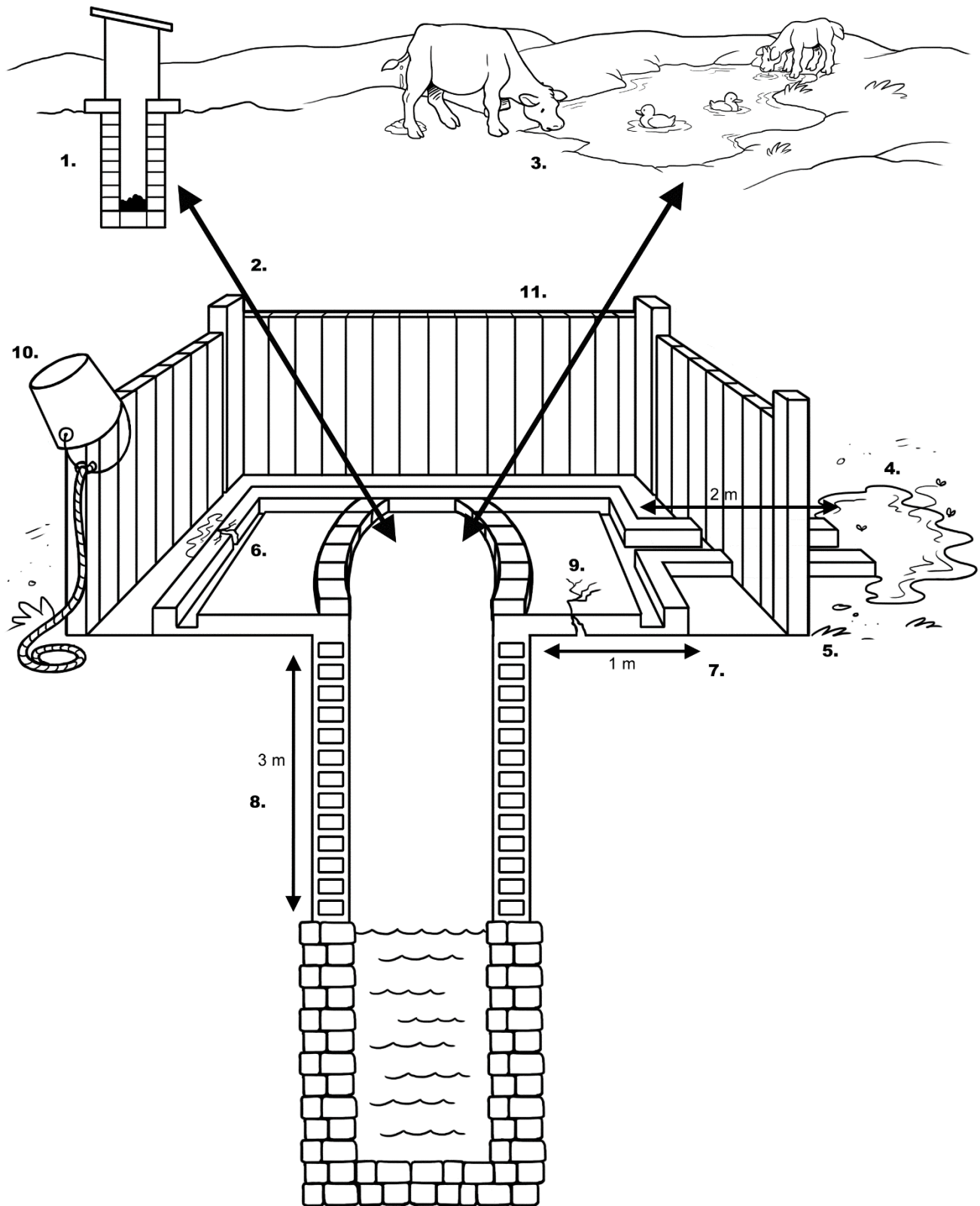

Sanitary Inspection Form: Protected Spring

Part 1. General information:

- a. Spring location:
- b. Village/Town:
- c. People served:
- d. Water sample taken? Sample ID
- e. Date of visit:

Part 2. Risk assessment: Circle the most appropriate answer. A 'Yes' answer means that there is a potential risk and a 'No' answer that there is no or very low risk. See explanation on reverse.

Observation

- | | |
|--|-----|
| 1. Is the collection or spring box absent or faulty? | Y/N |
| 2. Is the masonry or backfill area protecting the spring faulty or eroded? | Y/N |
| 3. If there is a spring box, is there an unsanitary inspection cover? | Y/N |
| 4. Does the spring box contain contaminating silt or animals? | Y/N |
| 5. Is there an air vent in the masonry and is it unsanitary? | Y/N |
| 6. Is there an overflow pipe, is it unsanitary? | Y/N |
| 7. Is the fence around the spring inadequate? | Y/N |
| 8. Can animals have access to within 10 m of the spring? | Y/N |
| 9. Is the diversion ditch above the spring absent or not working properly? | Y/N |
| 10. Are there any other sources of contamination uphill of the spring (e.g., latrines, waste)? | Y/N |

Risk of contamination (add the number of 'Yes' answers):/10

Part 3. Results and comments:

a. Risk of contamination (check appropriate box):

9-10 = Very high	6-8 = High	3-5 = Medium	0-2 = Low

b. The following risks were observed:

Part 4. Name and signature of inspectors:



Explanatory Notes: Protected Spring

1. *Is the collection or spring box absent or faulty?* The box helps to protect the water from contamination by surface water run-off. There is a risk to water quality if the box is absent or faulty.
2. *Is the masonry or backfill area protecting the spring faulty or eroded?* The masonry diverts surface water run off away from the spring box, protecting the water source from contamination. The backfill area protects the masonry, as well as helping to divert run off.
3. *If there is a spring box, is there an unsanitary inspection cover?* If the inspection cover (if present) is dirty, then the water source can become contaminated.
4. *Does the spring box contain contaminating silt or animals?* Silt accumulation or animals that have access to the spring box can be a source of water contamination.
5. *Is there an air vent in the masonry and is it unsanitary?* A dirty air vent can be another source of water contamination.
6. *Is there an overflow pipe, is it unsanitary?* If water does not drain away from the area, then water (possibly contaminated) could backflow into the water source or the soil can erode away and cause damage to the spring box.
7. *Is the fence around the spring inadequate?* If there is no fence or the fence is damaged, then animals can access the spring and may damage the structure as well as contaminate the area with feces. You will need to check the fencing at the site as well as check whether animals are routinely in the area (sometimes animals are kept in the fenced area for security).
8. *Can animals have access within 10 m of the spring?* Animals may damage the spring box as well as contaminate the area with feces. You will need to check the protection of the site and whether animals are routinely in the area.
9. *Is the diversion ditch above the spring absent or not working properly?* The diversion ditch protects the water source from possibly contaminated surface water run-off by directing it away from and downhill of the box. If the ditch is filled with waste or is poorly contoured, then run-off could collect and enter the source posing a risk to water quality.
10. *Are there any other sources of contamination uphill of the spring (e.g., latrines, waste)?* Contamination on higher ground poses a risk, especially in the wet season, as feces (and other contaminants) may flow into the water source. The risk is increased if no surface water diversion is present. Groundwater may also flow towards the spring box from the direction of a latrine.

Sanitary Inspection Form adapted from:

World Health Organization (2012). Rapid Assessment of Drinking-Water Quality: A Handbook for Implementation. WHO, Geneva, Switzerland. Available at: www.who.int/water_sanitation_health/publications/2012/rapid_assessment/en/index.html

World Health Organization (2005). Water Safety Plans: Managing Drinking-Water Quality from Catchment to Consumer. WHO, Geneva Switzerland. Available at: www.who.int/water_sanitation_health/dwq/wsp0506/en/index.html

World Health Organization (1997). Guidelines for Drinking Water Quality, Second Edition, Volume 3, Surveillance and Control of Community Supplies. WHO, Geneva, Switzerland. Available at: www.who.int/water_sanitation_health/dwq/gdwq2v1/en/index2.html



Illustration of Protected Spring

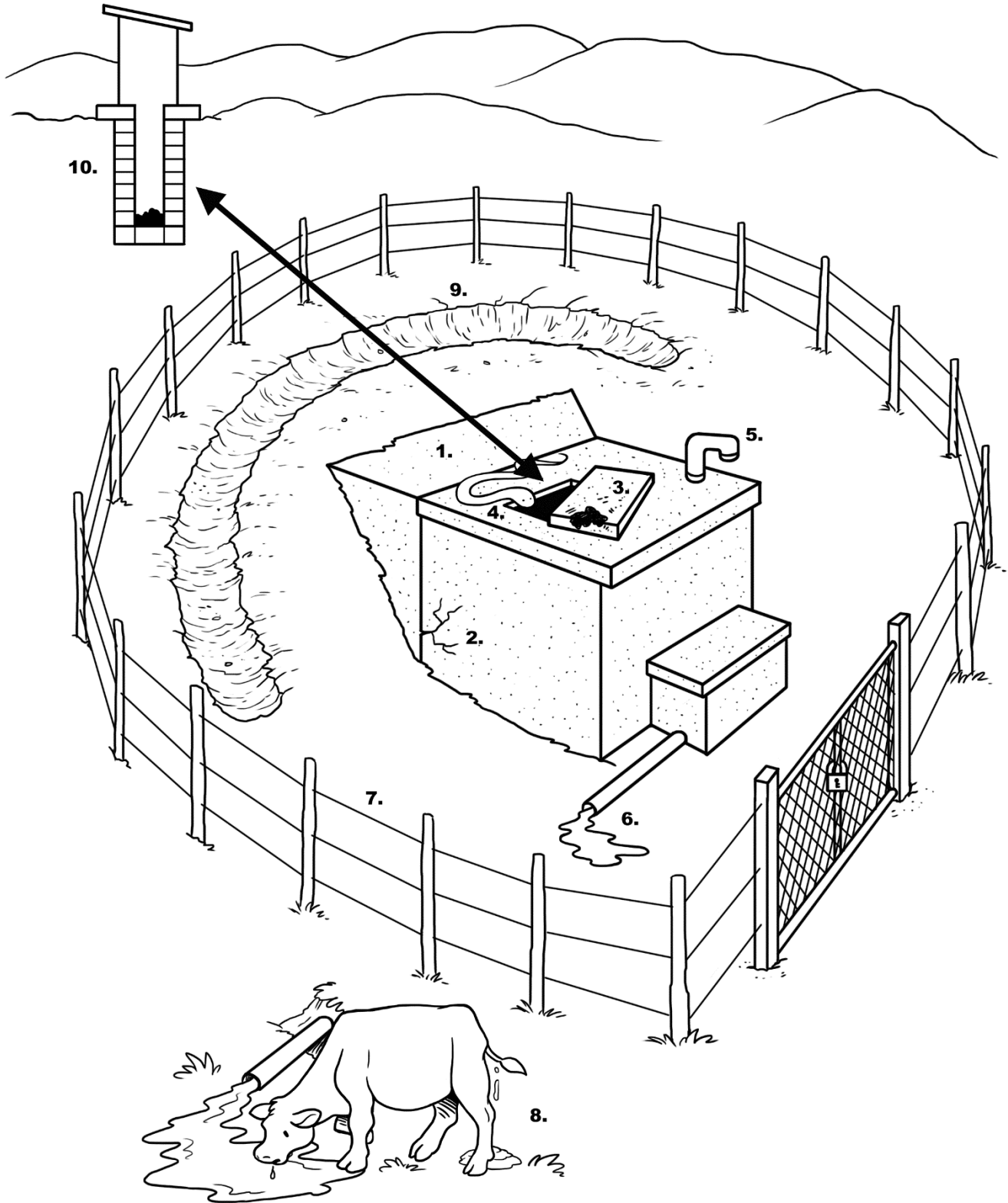

Sanitary Inspection Form: Rainwater Harvesting Tank

Part 1. General information:

- a. Tank location:
- b. Village/Town:
- c. People served:
- d. Water sample taken? Sample ID
- e. Date of visit:

Part 2. Risk assessment: Circle the most appropriate answer. A 'Yes' answer means that there is a potential risk and a 'No' answer that there is no or very low risk. See explanation on reverse.

Observation

- | | |
|--|-----|
| 1. Are there visible signs of contamination on the roof (e.g., feces, dirt, leaves)? | Y/N |
| 2. Is the gutter system that collects rainwater dirty or blocked? | Y/N |
| 3. Are there any problems with the filter box or first flush system at the tank inlet? | Y/N |
| 4. Is there any other point of entry to the tank that is not properly covered? | Y/N |
| 5. Is the top or wall of the tank cracked or damaged? | Y/N |
| 6. Is the tap leaking or broken? | Y/N |
| 7. Is the concrete floor under the tap missing, broken or dirty? | Y/N |
| 8. Is the water collection area inadequately drained? | Y/N |
| 9. Is there any source of contamination around the tank or water collection area? | Y/N |
| 10. Is a bucket in use and left in a place where it may become contaminated? | Y/N |

Risk of contamination (add the number of 'Yes' answers:/10

Part 3. Results and comments:

a. Risk of contamination (check appropriate box):

9-10 = Very high	6-8 = High	3-5 = Medium	0-2 = Low

b. The following risks were observed:

Part 4. Name and signature of inspectors:



Explanatory Notes: Rainwater Harvesting Tank

- 1. Are there visible signs of contamination on the roof (e.g. feces, dirt, leaves)?* Water quality is at risk if the roof is dirty or contaminated.
- 2. Is the gutter system that collects rainwater dirty or blocked?* Dirty gutters can contaminate the rainwater or introduce dirt into the tank in the same way the roof can.
- 3. Are there any problems with the filter box or first flush system at the tank inlet?* Rainwater harvesting tanks should have a way to divert the first water collected during a rainstorm. The first flow (especially at the end of the dry season) may contain vegetation, dirt, and animal feces washed from the roof, which are a risk to water quality.
- 4. Is there any other point of entry to the tank that is not properly covered?* Open rainwater collection tanks collect dust and dirt from the air, which is a possible risk to water quality. They can also be mosquito breeding sites, and the mosquitoes may spread dengue fever and malaria, which is a health risk (though not a water quality risk).
- 5. Is the top or wall of the tank cracked or damaged?* Deep cracks can allow contaminants to reach the rainwater stored in the tank.
- 6. Is the tap leaking or broken?* A broken tap can become a pathway for contaminants. You will need to check that any water around the tap is from a leak rather than from being spilled.
- 7. Is the concrete floor under the tap missing, broken or dirty?* Missing or broken drainage under the tap can lead to pools of water collecting which pose a risk.
- 8. Is the water collection area inadequately drained?* If water does not drain away from the collection area, then water (possibly contaminated) could backflow into the water source or the soil can erode away and cause damage to the tank.
- 9. Is there any source of contamination around the tank or water collection area?* Feces, garbage and other waste are a risk to the water quality.
- 10. Is a bucket in use and left in a place where it may become contaminated?* Buckets, cups or other devices used to collect water need to be properly stored and kept clean so that safe drinking water does become contaminated.

Sanitary Inspection Form adapted from:

World Health Organization (2012). Rapid Assessment of Drinking-Water Quality: A Handbook for Implementation. WHO, Geneva, Switzerland. Available at: www.who.int/water_sanitation_health/publications/2012/rapid_assessment/en/index.html

World Health Organization (2005). Water Safety Plans: Managing Drinking-Water Quality from Catchment to Consumer. WHO, Geneva Switzerland. Available at: www.who.int/water_sanitation_health/dwq/wsp0506/en/index.html

World Health Organization (1997). Guidelines for Drinking Water Quality, Second Edition, Volume 3, Surveillance and Control of Community Supplies. WHO, Geneva, Switzerland. Available at: www.who.int/water_sanitation_health/dwq/gdwq2v1/en/index2.html



Illustration of a Rainwater Harvesting Tank

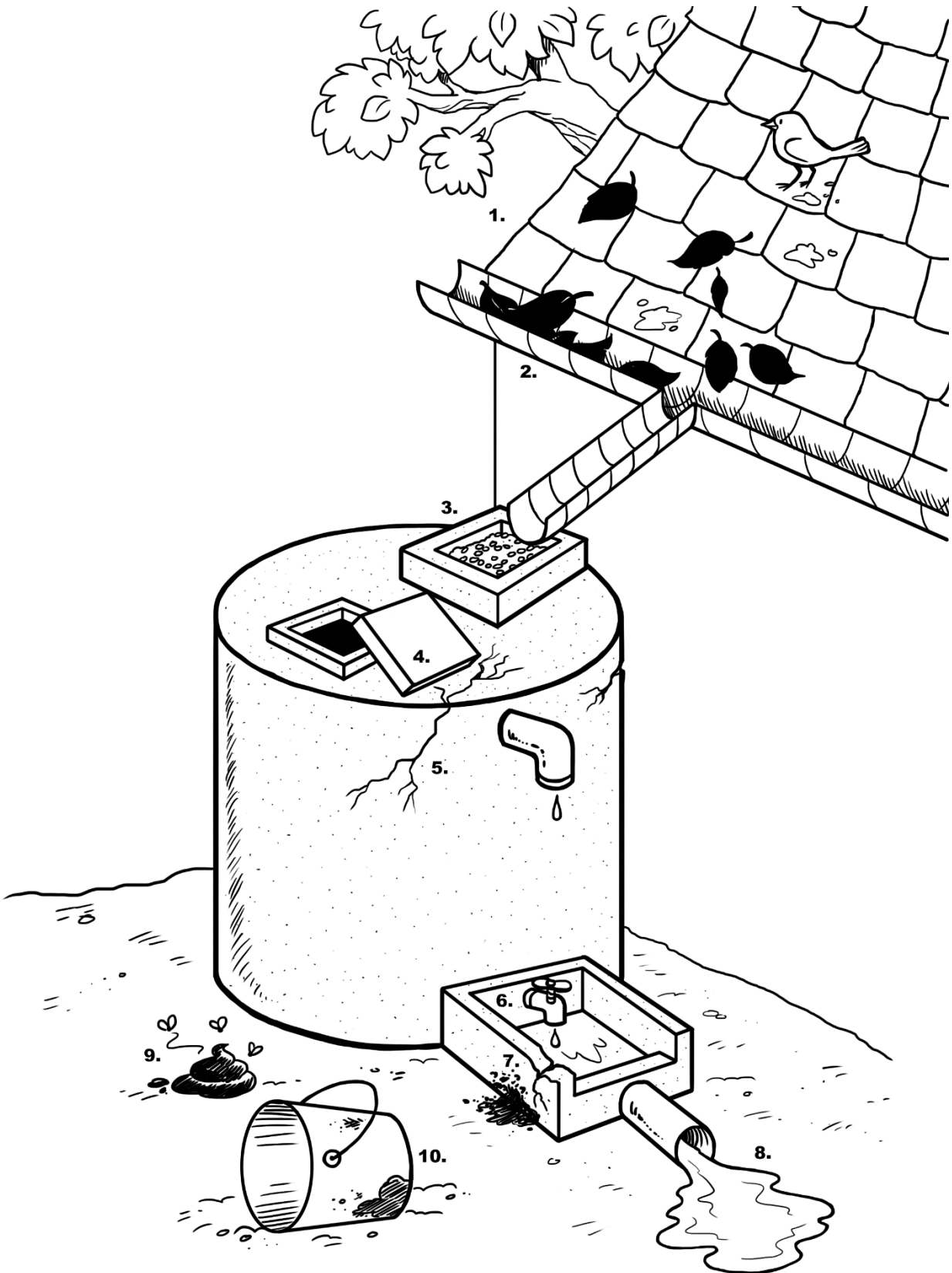

Introduction to Drinking Water Quality Testing

Appendix 2: Product Sheets

Drinking Water Quality Testing: Chemical Product Sheet: Arsenic Test Kit

Product Name:	Arsenic Field Test Kit
Test Type:	Colorimetric
Product Description:	ENPHO has developed a semi-quantitative low cost field kit for testing arsenic in drinking water. The kit uses visual colour comparison to give results within the range of 10-500 µg/L. The test kit is easy to use, portable, and gives rapid results (within 10 minutes); however it is not as accurate or precise as digital test kits. The reagents can be refilled by ENPHO.
Manufacturer:	Environment and Public Health Organization (ENPHO) 110/25 Adarsa Marg-1, Thapagaon, New Baneshwor, G.P.O Box No: 4102 Kathmandu (East), Nepal Tel: + 977-1-4468641, 4493188 Fax: + 977-1-4491376 E-mail: enpho@enpho.org Website: www.enpho.org/field-test-kits.html
Distributors:	None
Availability:	ENPHO is willing to ship the product from Nepal to other countries.
Cost:	Rs.5700.00 (approximately US\$58) per 50 tests (13% VAT extra)



ENPHO Arsenic Field Test Kit
(Credit: ENPHO)

Drinking Water Quality Testing: Chemical Product Sheet: Arsenic Test Kit

CAWST (Centre for Affordable Water and Sanitation Technology)
Calgary, Alberta, Canada
Website: www.cawst.org Email: resources@caust.org
Wellness through Water.... Empowering People Globally
Last Update: October 2013

This document is open content. You are free to:



- Share – to copy, distribute and transmit this document
- Remix – to adapt this document



Under the following conditions:

- Attribution. You must give credit to CAWST as the original source of the document. Please include our website: www.cawst.org

CAWST does not assume any responsibility for and makes no warranty with respect to the quality of the product described in this document.



Drinking Water Quality Testing: Chemical Product Sheet: Arsenic Test Kit

Product Name:	Arsenic Low Range Test Kit (Product #2800000)
Test Type:	Test strips
Product Description:	The test strips provide a simple and visual comparison test for arsenic. The results are measured in increments of 0, 10, 30, 50, 70, 300, 500 $\mu\text{g/L}$. Includes reagents, test strips, reaction vessel, measuring scoop, instructions, and carrying case
Manufacturer:	Hach Company Loveland, Colorado USA Tel: 1-800-227-4224 Fax: +1-970-669-2932 Email: orders@hach.com Outside the USA: Tel: +1-970-669-3050 Fax: +1-970-461-3939 Email: int@hach.com Website: www.hach.com
Distributors:	Various distributors worldwide Website: www.hach.com/global-distributor-support
Availability:	USA and international
Cost:	Need to contact Hach
Storage:	Contains mercury, store according to manufacturer's instructions
Maintenance:	Equipment needs to be cleaned according to manufacturer's instructions, waste needs to be disposed according to local regulations



Arsenic Low Range Test Kit (Credit: Hach)

Drinking Water Quality Testing: Chemical Product Sheet: Arsenic Test Kit

CAWST (Centre for Affordable Water and Sanitation Technology)
Calgary, Alberta, Canada
Website: www.cawst.org Email: resources@caust.org
Wellness through Water.... Empowering People Globally
Last Update: October 2013

This document is open content. You are free to:



- Share – to copy, distribute and transmit this document
- Remix – to adapt this document



Under the following conditions:

- Attribution. You must give credit to CAWST as the original source of the document. Please include our website: www.cawst.org

CAWST does not assume any responsibility for and makes no warranty with respect to the quality of the product described in this document.



Drinking Water Quality Testing: Chemical Product Sheet: Chlorine Colour Comparator

Product Name:	Chlorine (Free & Total) and pH Test Kit (Model CN-67)
Test Type:	Colour Comparator
Product Description:	This portable test kit comes with colour discs and a comparator for monitoring free and total chlorine, as well as pH. The kit contains all required reagents and apparatus in a carrying case for analysis in the field. The test kit can be used to measure free chlorine and/or total chlorine, with a range of 0 – 3.5 mg/L. It includes reagents, two color discs, comparator box, and two viewing tubes.
Manufacturer:	Hach Company Loveland, Colorado USA Tel: 1-800-227-4224 Fax: +1-970-669-2932 Email: orders@hach.com Outside the USA: Tel: +1-970-669-3050 Fax: +1-970-461-3939 Email: int@hach.com Website: www.hach.com
Distributors:	Various distributors worldwide Website: www.hach.com/global-distributor-support
Availability:	USA and international
Cost:	US\$90 per test kit (300 samples) US\$27 per reagent refills (50)
Storage:	0-50°C, 0-90% relative humidity
Maintenance:	Clean according to manufacturer's instructions
Other Necessary Products:	Pipette, pipette tips are recommended



Chlorine (Free & Total) and pH Test Kit (Credit: Hach)

Drinking Water Quality Testing: Chemical Product Sheet: Chlorine Colour Comparator

CAWST (Centre for Affordable Water and Sanitation Technology)
Calgary, Alberta, Canada
Website: www.cawst.org Email: resources@caust.org
Wellness through Water.... Empowering People Globally
Last Update: October 2013

This document is open content. You are free to:



- Share – to copy, distribute and transmit this document
- Remix – to adapt this document



Under the following conditions:

- Attribution. You must give credit to CAWST as the original source of the document. Please include our website: www.cawst.org

CAWST does not assume any responsibility for and makes no warranty with respect to the quality of the product described in this document.



Drinking Water Quality Testing: Chemical Product Sheet: Fluoride Colorimeter

Product Name:	Pocket Colorimeter™ II, Fluoride (Product # 2513100)
Test Type:	Colorimeter
Product Description:	This fluoride colorimeter is battery-operated, waterproof, and will measure fluoride concentrations from 0.03 to 2 mg/L. It includes a reagent set (50 tests), manual, and carrying case. The Accuvac Reagents offer an alternative to measuring reagents. Ampoules contain the precise amount of reagent for a single test and can be used as a measurement cuvette. Just immerse the tip of the ampoule in your sample and break off the tip. The glass ampoules are vacuum packed and automatically draw in your sample. Then place the ampoules directly in the colorimeter for analysis. Included: reagents, 2-10 mL sample cells, 4 AAA batteries, carrying case, and lanyard.
Manufacturer:	Hach Company Loveland, Colorado USA Tel: 1-800-227-4224 Fax: +1-970-669-2932 Email: orders@hach.com Outside the USA: Tel: +1-970-669-3050 Fax: +1-970-461-3939 Email: int@hach.com Website: www.hach.com
Distributors:	Various distributors worldwide Website: www.hach.com/global-distributor-support
Availability:	USA and international
Cost:	US\$427 per test kit (50 tests) US\$37.28 Accuvac Fluoride Reagent Refill (25 tests)
Storage:	0-50°C, 0-90% relative humidity
Maintenance:	Batteries need to be replaced after approximately 2,000 tests, 2 year warranty



Hach Pocket Colorimeter™ II, Fluoride (Credit: Hach)

Drinking Water Quality Testing: Chemical Product Sheet: Fluoride Colorimeter

CAWST (Centre for Affordable Water and Sanitation Technology)
Calgary, Alberta, Canada
Website: www.cawst.org Email: resources@caust.org
Wellness through Water.... Empowering People Globally
Last Update: October 2013

This document is open content. You are free to:



- Share – to copy, distribute and transmit this document
- Remix – to adapt this document



Under the following conditions:

- Attribution. You must give credit to CAWST as the original source of the document. Please include our website: www.cawst.org

CAWST does not assume any responsibility for and makes no warranty with respect to the quality of the product described in this document.



Drinking Water Quality Testing: Chemical Product Sheet: Arsenic Test Kit

Product Name: Arsenator®: Digital Arsenic Test Kit

Test Type: Photometer

Product Description: The Arsenator® is a portable arsenic test kit that was designed specifically for field use and tested with UNICEF/WHO. The Arsenator uses a photometer to digitally measure the colour change on mercuric bromide filter paper based on the Gutzeit method. It is more accurate and precise than visual colour comparison kits, and gives results between 2 µg/L to 100 µg/L. The test kit includes:

- Tri-Filter Arsenic gas trap
- 5 x Arsenic collection filter holders
- 5 x Arsine gas removal filter holders
- 10 x Hydrogen Sulphide removal filters
- 420 x Reagent A1 (dry powder sachet)
- 420 x Tablet A2
- 420 x Arsenic collection filters
- 420 x Arsine gas removal filters
- Colour comparison chart (<10 to 500 µg/L)
- Dilution tube
- Spare battery
- Waste disposal bags
- Gloves and tweezers
- Carrying case



Arsenator® (Credit: Palintest)

Manufacturer: Palintest Ltd
Palintest House, Kingsway, Team Valley,
Gateshead, Tyne and Wear
United Kingdom, NE11 0NS
Tel: +44 (0) 191 491 0808
Fax: +44 (0) 191 482 5372
Email: export@palintest.com
Website: www.palintest.com

Distributors: Palintest has regional offices official agents and distributors serving customers in over 90 countries
Email: export@palintest.com

Availability: UK and international

Cost: £650 (approximately US\$1,055)

Maintenance: Battery needs to be replaced regularly, equipment needs to be cleaned according to manufacturer's instructions, waste needs to be disposed according to local regulations

Drinking Water Quality Testing: Chemical Product Sheet: Arsenic Test Kit

References:

UNICEF (2008). UNICEF Handbook on Water Quality. UNICEF, New York, USA. Available at: www.unicef.org/wash/files/WQ_Handbook_final_signed_16_April_2008.pdf

CAWST (Centre for Affordable Water and Sanitation Technology)
Calgary, Alberta, Canada
Website: www.cawst.org Email: resources@caust.org
Wellness through Water.... Empowering People Globally
Last Update: October 2013

This document is open content. You are free to:



- Share – to copy, distribute and transmit this document
- Remix – to adapt this document



Under the following conditions:

- Attribution. You must give credit to CAWST as the original source of the document. Please include our website: www.cawst.org

CAWST does not assume any responsibility for and makes no warranty with respect to the quality of the product described in this document.



Drinking Water Quality Testing: Chemical Product Sheet: Colour Comparator

Product Name:	Contour Comparator
Test Type:	Colour comparator
Product Description:	The Contour Comparator kit uses tablet reagents and colour charts to test different chemical parameters. Just add a tablet reagent to the test sample, place the tube in the comparator, and match the colour against the appropriate colour disc. Each kit is supplied with the Contour Comparator, 2 Contour colour discs, 3 test tubes, crush/stir rod, test tube brush and reagents for 30 tests per parameter.
Manufacturer:	Palintest Ltd Palintest House, Kingsway, Team Valley, Gateshead, Tyne and Wear United Kingdom, NE11 0NS Tel: +44 (0) 191 491 0808 Fax: +44 (0) 191 482 5372 Email: export@palintest.com Website: www.palintest.com
Distributors:	Palintest has regional offices official agents and distributors serving customers in over 90 countries Email: export@palintest.com
Availability:	UK and international
Cost:	Single parameter contour kits are £39.95 (approximately US\$65) Dual parameter contour kits are £49.95 (approximately US\$81) Replacement Colour Discs are £19.95 each (approximately US\$32)
Maintenance:	Clean according to manufacturer's instructions.



Left: Contour Comparator with test tubes and colour disc, Right: Colour disc (Credit: Palintest)

Drinking Water Quality Testing: Chemical Product Sheet: Colour Comparator

CAWST (Centre for Affordable Water and Sanitation Technology)
Calgary, Alberta, Canada
Website: www.cawst.org Email: resources@caust.org
Wellness through Water.... Empowering People Globally
Last Update: October 2013

This document is open content. You are free to:



- Share – to copy, distribute and transmit this document
- Remix – to adapt this document



Under the following conditions:

- Attribution. You must give credit to CAWST as the original source of the document. Please include our website: www.cawst.org

CAWST does not assume any responsibility for and makes no warranty with respect to the quality of the product described in this document.



Drinking Water Quality Testing: Chemical Product Sheet: Photometer

Product Name:	Photometer 7100 (Product # PT740)
Test Type:	Photometer
Product Description:	The Photometer 7100 can test over 40 chemical parameters, including fluoride, nitrate, nitrite, iron, manganese, and pH. A reagent is added to the water sample and the photometer assesses the colour formed in the test sample and displays the digital readings on a LCD screen. It is waterproof and runs on 3 AA batteries. Display languages include English, French, German, Spanish, and Italian.
Manufacturer:	Palintest Ltd Palintest House, Kingsway, Team Valley, Gateshead, Tyne and Wear United Kingdom, NE11 0NS Tel: +44 (0) 191 491 0808 Fax: +44 (0) 191 482 5372 Email: export@palintest.com Website: www.palintest.com
Distributors:	Palintest has regional offices official agents and distributors serving customers in over 90 countries Email: export@palintest.com
Availability:	UK and international
Cost:	£670 (approximately US\$1,087). Reagents are sold separately.
Maintenance:	Batteries need to be replaced. Needs to be calibrated according to manufacturer's instructions.



Photometer 7100 (Credit: Palintest)

Drinking Water Quality Testing: Chemical Product Sheet: Photometer

CAWST (Centre for Affordable Water and Sanitation Technology)
Calgary, Alberta, Canada
Website: www.cawst.org Email: resources@caust.org
Wellness through Water.... Empowering People Globally
Last Update: October 2013

This document is open content. You are free to:



- Share – to copy, distribute and transmit this document
- Remix – to adapt this document



Under the following conditions:

- Attribution. You must give credit to CAWST as the original source of the document. Please include our website: www.cawst.org

CAWST does not assume any responsibility for and makes no warranty with respect to the quality of the product described in this document.



Drinking Water Quality Testing: Chemical, Physical Product Sheet: Colorimeter

Product Name:	DR 900 Multiparameter Handheld Colorimeter (Product #9385100)
Test Type:	Colorimeter
Product Description:	This colorimeter is battery-operated, waterproof, and dustproof. It is able to test up to 90 of the most common chemical and physical parameters in drinking water, including chlorine, fluoride, iron, manganese, nitrate/nitrite, pH, and turbidity. The colorimeter can store up to 500 data sets with sample ID and user ID. It can transfer data using a USB cable with no software or accessories needed. User languages include English, French and Spanish (among others). Included: two 25 mL glass vials, two 10 mL plastic vials, USB cable, and four AA batteries.
Manufacturer(s):	Hach Company Loveland, Colorado USA Tel: 1-800-227-4224 Fax: +1-970-669-2932 Email: orders@hach.com Outside the USA: Tel: +1-970-669-3050 Fax: +1-970-461-3939 Email: int@hach.com Website: www.hach.com
Distributors(s):	Various distributors worldwide Website: www.hach.com/global-distributor-support
Availability:	USA and international
Cost:	Approximately US\$1,500.00
Storage:	0-50°C, maximum 90% relative humidity
Maintenance:	Batteries need to be replaced about every 6 months (based on 5 readings per day/5 days per week), 2 year warranty



DR 900 Multi-parameter Handheld Colorimeter (Credit: Hach)

Drinking Water Quality Testing: Chemical, Physical Product Sheet: Colorimeter

CAWST (Centre for Affordable Water and Sanitation Technology)
Calgary, Alberta, Canada
Website: www.cawst.org Email: resources@caust.org
Wellness through Water.... Empowering People Globally
Last Update: October 2013

This document is open content. You are free to:



- Share – to copy, distribute and transmit this document
- Remix – to adapt this document



Under the following conditions:

- Attribution. You must give credit to CAWST as the original source of the document. Please include our website: www.cawst.org

CAWST does not assume any responsibility for and makes no warranty with respect to the quality of the product described in this document.



Drinking Water Quality Testing: Microbiological Product Sheet: Petrifilm™

Product Name: 3M™ Petrifilm™ *E. coli*/Coliform Count Plates

Test Type: Plate method for *E. coli* and coliform

Product Description: Petrifilm is an all-in-one plating system. A typical Petrifilm has a 10 cm × 7.5 cm bottom film which contains a foam barrier to surround the plating surface, the plating surface itself (a circular area of about 20 cm²), and a top film which encloses the water sample within the Petrifilm. A 1 cm × 1 cm yellow grid is printed on the back to help with counting. Petrifilm is available in packages of 50 or 500 tests.

There are three steps for using Petrifilm:

1. Inoculate by lifting the top film and adding a 1 mL water sample
2. Incubate for 24-48 hours
3. Count the colonies. Confirmed coliforms are red and blue colonies with associated gas bubbles. Confirmed *E. coli* coliforms are blue colonies with associated gas bubbles.

Manufacturer(s): 3M Corporation
St. Paul, MN
55144-1000, USA
Tel: 1-800-328-6553 (USA)
Tel: +1-651-733-7562 (Latin America/Africa and Asia Pacific regions)
Website: www.3m.com

Distributor(s): Unknown

Availability: US and international

Cost: Approximately US\$100 for 50 plates

Storage: Store unopened Petrifilm pouches refrigerated or frozen at temperatures ≤8°C. Store resealed pouches in a cool dry place for no longer than one month. Plates should not be used past their expiration date.

Other Necessary Products: Pipette or calibrated dropper, incubator, bleach (for disposal), permanent marker



Petrifilm plates (Credit: 3M, 2001)

Drinking Water Quality Testing: Microbiological Product Sheet: Petrifilm™

CAWST (Centre for Affordable Water and Sanitation Technology)
Calgary, Alberta, Canada
Website: www.cawst.org Email: resources@caust.org
Wellness through Water.... Empowering People Globally
Last Update: October 2013

This document is open content. You are free to:



- Share – to copy, distribute and transmit this document
- Remix – to adapt this document



Under the following conditions:

- Attribution. You must give credit to CAWST as the original source of the document. Please include our website: www.cawst.org

CAWST does not assume any responsibility for and makes no warranty with respect to the quality of the product described in this document.



Drinking Water Quality Testing: Microbiological Product Sheet: Absorbent Pads

Product Name:	Absorbent Pads
Test Type:	Membrane filtration
Product Description:	<p>Absorbent pads are needed when using liquid culture media for membrane filtration (not agars). They can be purchased in different ways:</p> <ul style="list-style-type: none">• In plastic Petri dishes (and sometimes already impregnated with dehydrated culture media)• With membrane filters• Separately (usually sold with a dispenser)
Manufacturers:	<p>There are many manufacturers worldwide of absorbent pads. The most commonly known is Millipore based in the USA and Whatman™ based in the UK. Both manufacturers have regional offices and distributors.</p> <p>Millipore: www.millipore.com Whatman: www.whatman.com</p>
Availability:	International
Cost:	Varies depending on manufacturer, about US\$7 for a pack of 30
Other Necessary Products:	Dispenser (optional depending on product), membrane filters, Petri dishes, culture media



Millipore absorbent pads with dispenser
(Credit: Fischer Scientific)



Millipore absorbent pads with Petri dishes
(Credit: Capitol Scientific)

Drinking Water Quality Testing: Microbiological Product Sheet: Absorbent Pads

CAWST (Centre for Affordable Water and Sanitation Technology)
Calgary, Alberta, Canada
Website: www.cawst.org Email: resources@caust.org
Wellness through Water.... Empowering People Globally
Last Update: October 2013

This document is open content. You are free to:



- Share – to copy, distribute and transmit this document
- Remix – to adapt this document



Under the following conditions:

- Attribution. You must give credit to CAWST as the original source of the document. Please include our website: www.cawst.org

CAWST does not assume any responsibility for and makes no warranty with respect to the quality of the product described in this document.



Drinking Water Quality Testing: Microbiological Product Sheet: Compartment Bag Test

Product Name: Aquagenx Compartment Bag Test (CBT)

Test Type: Most Probable Number (MPN) of *Escherichia coli* (*E. coli*) in 100 mL

Product Description: The Compartment Bag Test (CBT) is a portable, self-contained water quality test kit to determine if drinking water contains *E. coli*.

A water sample is collected in a 100 mL bottle, and a chromogenic *E. coli* growth medium is added to the sample. After the medium dissolves, the sample is poured into the bag that contains five compartments of different volumes totaling 100 mL. The bag is sealed shut and the sample incubates at ambient temperature at 25°C and above for 24 hours. For temperatures below 25°C, an insulated container or portable incubator is recommended, as well as a longer incubation period. The sample turns colors. A blue or blue-green color indicates a positive presence of *E. coli*. A yellow or yellow-brown color indicates absence of *E. coli*. The concentration of fecal bacteria is estimated from the combination of positive and negative compartments, giving a Most Probable Number estimate of *E. coli* per 100 mL. After scoring test results, chlorine tablets are added to the sample for decontamination and safe disposal.

An instruction sheet, including an MPN Table for scoring test results and specific incubation times and temperatures, comes with the CBT Kit. There is also a video on the Aquagenx website that demonstrates how to use the test.

The Aquagenx CBT Kit includes complete supplies for 10 tests:

- 10 compartment bags
- 10 100 mL sample bottles
- 10 Aquagenx *E. coli* chromogenic culture medium test buds
- 30 chlorine tablets for sample disinfection and safe disposal
- 1 reusable sealing clip for safe transport of bags



Left: Positive (blue/blue green) and negative (yellow/yellow brown) compartments indicate *E. coli*
Right: CBT Kit includes complete supplies for 10 tests (Credit: Aquagenx)

Drinking Water Quality Testing: Microbiological Product Sheet: Compartment Bag Test

Manufacturer:	Aquagenx Tel: +1-919-590-0343 Email: info@aquagenx.com Website: www.aquagenx.com
Availability:	USA and can be shipped internationally
Cost:	Aquagenx provides volume-based pricing for CBT Kits. Contact Aquagenx for details. Shipping fees are added to the invoice.
Storage:	The culture media does not need to be refrigerated. Shelf life of the CBT Kit is one year from the date of manufacture.
Maintenance:	Product is disposed after single use.
Other Necessary Products:	Insulated container or portable incubator is recommended if ambient temperature is below 25°C.

CAWST (Centre for Affordable Water and Sanitation Technology)
Calgary, Alberta, Canada
Website: www.cawst.org Email: resources@cawst.org
Wellness through Water.... Empowering People Globally
Last Update: October 2013

This document is open content. You are free to:



- Share – to copy, distribute and transmit this document
- Remix – to adapt this document



Under the following conditions:

- Attribution. You must give credit to CAWST as the original source of the document. Please include our website: www.cawst.org

CAWST does not assume any responsibility for and makes no warranty with respect to the quality of the product described in this document.



Drinking Water Quality Testing: Microbiological Product Sheet: Presence-Absence Test

Product Name: Presence-Absence Test

Test Type: Presence-Absence (P-A)

Indicator: H₂S

Product Description: This test is used to detect thermotolerant coliform contamination of drinking water. It shows whether the bacteria is present or absent by turning the solution in the vial black within 48 hours. False positives may occur due to sources other than fecal contamination (i.e., water containing sulphate-reducing bacteria, groundwater with naturally high sulphide levels). This test is not recommended for testing water that is known or likely to be contaminated, such as surface water and untreated small community supplies. It is also not recommended for testing the effectiveness of household water treatment technologies.

Manufacturer: Environment and Public Health Organization (ENPHO)
110/25 Adarsa Marg-1, Thapagaon, New Baneshwor,
G.P.O Box No: 4102
Kathmandu (East), Nepal
Tel: + 977-1-4468641, 4493188
Fax: + 977-1-4491376
E-mail: enpho@enpho.org
Website: www.enpho.org/research-and-development/analysis.html

Distributors: None

Availability: ENPHO is willing to ship the product from Nepal to other countries. Seeds of Hope International Partnerships also manufacture the test in Zambia using ENPHO's method.

Cost: Rs.45.00 or approximately US\$0.47 per test

Storage: No specific requirements identified.

Maintenance: No maintenance required. Bottles are disposed after use.

Other Necessary Products: Permanent marker



ENPHO presence-absence test bottles showing negative (clear) and positive (black) results (Credit: ENPHO)

Drinking Water Quality Testing: Microbiological Product Sheet: Presence-Absence Test

CAWST (Centre for Affordable Water and Sanitation Technology)
Calgary, Alberta, Canada
Website: www.cawst.org Email: resources@caust.org
Wellness through Water.... Empowering People Globally
Last Update: October 2013

This document is open content. You are free to:



- Share – to copy, distribute and transmit this document
- Remix – to adapt this document



Under the following conditions:

- Attribution. You must give credit to CAWST as the original source of the document. Please include our website: www.cawst.org

CAWST does not assume any responsibility for and makes no warranty with respect to the quality of the product described in this document.



Drinking Water Quality Testing: Microbiological Product Sheet: Filter Paper

Product Name: Filter paper, also known as membrane filters

Test Type: Membrane filtration

Product Description: In the membrane filtration test procedure, the water sample is filtered through a filter paper and the bacteria are trapped on the surface. The filter paper is then placed in a Petri dish with culture media and incubated to grow bacteria colonies which can be counted.

Filter papers are also known as cellulose nitrate (CN) filters or mix cellulose ester filters. The most common size is 45 mm diameter, which fits in standard membrane filtration equipment, such as Wagtech and Delagua portable test kits and Nalgene filter units. The pore size should be 0.45 μm for typical microbiological testing of *E. coli* and thermotolerant (fecal) coliforms. It is best to use white filters with printed grids to make it easier to count the bacteria colonies. The filter papers are sterile and individually wrapped, and sometimes sold with absorbent pads. They should only be handled with sterilized forceps and not touched directly to prevent their contamination.

Manufacturers: There are many manufacturers worldwide of filter papers. The most commonly known is Millipore based in the USA and Whatman™ based in the UK. Both manufacturers have regional offices and distributors.

Millipore: www.millipore.com/catalogue/module/c152#1

Whatman: www.whatman.com/MicroPlusandMEMembranes.aspx

Availability: International

Cost: Varies depending on manufacturer

Other Necessary Products: Forceps, absorbent pads, Petri dishes, culture media



Filter paper with printed grid (Credit: Whatman)



Individually packaged filter papers (Credit: Millipore)

Drinking Water Quality Testing: Microbiological Product Sheet: Filter Paper

CAWST (Centre for Affordable Water and Sanitation Technology)
Calgary, Alberta, Canada
Website: www.cawst.org Email: resources@cawst.org
Wellness through Water.... Empowering People Globally
Last Update: October 2013

This document is open content. You are free to:



- Share – to copy, distribute and transmit this document
- Remix – to adapt this document



Under the following conditions:

- Attribution. You must give credit to CAWST as the original source of the document. Please include our website: www.cawst.org

CAWST does not assume any responsibility for and makes no warranty with respect to the quality of the products described in this document.



Drinking Water Quality Testing: Microbiological Product Sheet: Presence-Absence Test

Product Name:	PathoScreen™ Field Test Kit (Product #2859100)
Test Type:	Presence-Absence (P-A)
Indicator:	H ₂ S
Product Description:	<p>This test kit is used to detect thermotolerant coliform contamination of drinking water. The Pathoscreen culture media comes in pillows (like sachets) with enough powder to test 100 mL of water. The sample water is put in sterilized bottles, and the contents of PathoScreen powder pillow is added and left for 24 hours. The change in colour indicates the safety of the water. False positives may occur due to sources other than fecal contamination (i.e., water containing sulphate-reducing bacteria, groundwater with naturally high sulphide levels). This test is not recommended for testing water that is known or likely to be contaminated, such as surface water and untreated small community supplies. It is also not recommended for testing the effectiveness of household water treatment technologies. This test kit provides for 100 P-A tests and 20 most probable number (MPN) results. Includes Pathoscreen powder pillows, bleach solution, and carrying case.</p>
Manufacturer:	<p>Hach Company Loveland, Colorado USA Tel: 1-800-227-4224 Fax: +1-970-669-2932 Email: orders@hach.com</p> <p>Outside the USA: Tel: +1-970-669-3050 Fax: +1-970-461-3939 Email: int@hach.com Website: www.hach.com</p>
Distributors:	<p>Various distributors worldwide Website: www.hach.com/global-distributor-support</p>
Availability:	USA and international
Cost:	US\$48.00
Storage:	No refrigeration required for media.
Other Necessary Products:	Permanent marker



Illustrations Top: Complete test kit, Bottom: Extra Pathoscreen pillows (Credit: HACH)

Drinking Water Quality Testing: Microbiological Product Sheet: Presence-Absence Test

CAWST (Centre for Affordable Water and Sanitation Technology)
Calgary, Alberta, Canada
Website: www.cawst.org Email: resources@caust.org
Wellness through Water.... Empowering People Globally
Last Update: October 2013

This document is open content. You are free to:



- Share – to copy, distribute and transmit this document
- Remix – to adapt this document



Under the following conditions:

- Attribution. You must give credit to CAWST as the original source of the document. Please include our website: www.cawst.org

CAWST does not assume any responsibility for and makes no warranty with respect to the quality of the product described in this document.



Drinking Water Quality Testing: Microbiological Product Sheet: Portable Incubator

Product Name:	Portable Incubator (Product #2569900)
Test Type:	Incubator for microbiological testing
Product Description:	This incubator can be used with a variety of power sources for reliable and accurate incubation. It has an operating range of 30 to 50°C, with an accuracy of +/-0.5°C at 37°C. The incubator can hold 6 Presence-Absence (P-A) test bottles, 39 most probable number (MPN) tubes, or 42 Petri dishes (50 mm each). Racks for P-A bottles, MPN tubes, and Petri dishes are sold separately. The external dimensions are 30.5 x 30.5 x 25.4 cm (12 x 12 x 10"). The power source is 12 volts direct current (vdc) using a vehicle cigarette lighter socket connection. Other power source options include 12 vdc rechargeable battery (12 hours of operation @ 37°C @ 20-25°C ambient) and 115/230 Vac Battery Eliminator. Includes power attachment for 12 vdc socket.
Manufacturer:	Hach Company Loveland, Colorado USA Tel: 1-800-227-4224 Fax: +1-970-669-2932 Email: orders@hach.com Outside the USA: Tel: +1-970-669-3050 Fax: +1-970-461-3939 Email: int@hach.com Website: www.hach.com
Distributors:	Various distributors worldwide Website: www.hach.com/global-distributor-support
Availability:	USA and international
Cost:	Approximately US\$1,500
Maintenance:	Regular calibration, clean according to manufacturer's instructions
Other Necessary Products:	Power source



Hach Portable Incubator (Credit: Hach)

Drinking Water Quality Testing: Microbiological Product Sheet: Portable Incubator

CAWST (Centre for Affordable Water and Sanitation Technology)
Calgary, Alberta, Canada
Website: www.cawst.org Email: resources@caust.org
Wellness through Water.... Empowering People Globally
Last Update: October 2013

This document is open content. You are free to:



- Share – to copy, distribute and transmit this document
- Remix – to adapt this document



Under the following conditions:

- Attribution. You must give credit to CAWST as the original source of the document. Please include our website: www.cawst.org

CAWST does not assume any responsibility for and makes no warranty with respect to the quality of the product described in this document.



Drinking Water Quality Testing: Microbiological Product Sheet: Portable Incubator

Product Name:	Hova-Bator Incubator
Test Type:	Incubator for microbiological testing
Product Description:	The Hova-Bator incubator is a simple and economical incubator that is usually used to hatch eggs. The incubator does not have a thermostat so it can be challenging to maintain a consistent temperature needed for microbiological testing. Culture media may dry out if it is left too long in the incubator and it is limited for sensitive culture media types.
Manufacturer:	G.Q.F. Manufacturing Company P.O. Box 1552 Savannah, GA 31402, USA Tel: +1-912-236-0651 Website: www.GQFMFG.com
Distributors:	Website: www.gqfmfg.com/store/international.asp
Availability:	USA and international
Cost:	US\$55.98
Maintenance:	Regular calibration, clean according to manufacturer's instructions, 1 year warranty
Other Necessary Products:	12 volt power source



Hova-Bator Incubator (Credit: GQF Manufacturing Company)

Drinking Water Quality Testing: Microbiological Product Sheet: Portable Incubator

CAWST (Centre for Affordable Water and Sanitation Technology)
Calgary, Alberta, Canada
Website: www.cawst.org Email: resources@caust.org
Wellness through Water.... Empowering People Globally
Last Update: October 2013

This document is open content. You are free to:



- Share – to copy, distribute and transmit this document
- Remix – to adapt this document



Under the following conditions:

- Attribution. You must give credit to CAWST as the original source of the document. Please include our website: www.cawst.org

CAWST does not assume any responsibility for and makes no warranty with respect to the quality of the product described in this document.



Drinking Water Quality Testing: Microbiological Product Sheet: Presence-Absence or Most Probable Number Tests

Product Name:	Colilert®
Test Type:	Presence-Absence (P-A) or Most Probable Number (MPN)
Product Description:	Colilert uses the patented Defined Substrate Technology® (DST®) to simultaneously detect themotolerant (fecal) coliform and total coliform bacteria. Two nutrient indicators, ONPG and MUG, are used to identify the coliform enzyme beta-galactosidase and the <i>Escherichia coli</i> (<i>E. coli</i>) enzyme beta-glucuronidase. After incubation, total coliforms change the culture media from colorless to yellow, and <i>E. coli</i> will fluoresce under a UV light.
Manufacturer:	IDEXX Laboratories, Inc. One IDEXX Drive Westbrook, Maine 04092 USA Tel: +1-207-556-4496 or 1-800-321-0207 Fax: +1-207-556-4630 Email: water@idexx.com Website: www.idexx.com
Availability:	USA and international
Cost:	15% discount available for educational and nonprofit research aid work organizations based in Canada and USA.

Catalogue Number	Manufacturing Number	Product Description	Price (US\$)
WP020I	98-12972-00	Colilert for 100 mL Sample, 20-pack	\$127
WP100I	98-27163-00	Colilert for 100 mL Sample, 100-pack	\$567
WP200I	98-12973-00	Colilert for 100 mL Sample, 200-pack	\$1,004
W100I	98-14770-00	Colilert Predispensed in 10 mL tubes, 100-pack	\$172
W200I	98-14771-00	Colilert Predispensed in 10 mL tubes, 200-pack	\$318
WQT100	98-21378-00	Quanti-Trays, 100-pack (0-200 MPN)	\$127
WQT-2K	98-21675-00	Quanti-Trays/2000, 200-pack (0-2,419 MPN)	\$173
WQTS2X-115	99-10893-01	IDEXX 110 Volt Quanti-Tray Sealer	\$4,200
WQTS2X-230	99-10896-01	IDEXX 220 Volt Quanti-Tray Sealer	\$4,200
WL200	98-06423-00	4-Watt Pocket UV Light	\$39

Storage: Store at 2-30°C and away from light , up to 12 month shelf life at room temperature

Other Necessary Products: Incubator, UV light for reading *E. coli* results
P-A method: sample container (transparent, nonfluorescing)
MPN method: test tubes or Quanti-Tray® or Quanti-Tray®/2000,
Quanti-Tray sealer

Drinking Water Quality Testing: Microbiological Product Sheet: Presence-Absence or Most Probable Number Tests



Left: Colilert package, Right: Presence-absence test bottles with positive results (Credit: IDEXX)

CAWST (Centre for Affordable Water and Sanitation Technology)
Calgary, Alberta, Canada
Website: www.cawst.org Email: resources@cawst.org
Wellness through Water.... Empowering People Globally
Last Update: October 2013

This document is open content. You are free to:



creative commons

- Share – to copy, distribute and transmit this document
- Remix – to adapt this document



Under the following conditions:

- Attribution. You must give credit to CAWST as the original source of the document. Please include our website: www.cawst.org

CAWST does not assume any responsibility for and makes no warranty with respect to the quality of the product described in this document.



Drinking Water Quality Testing: Microbiological Product Sheet: Most Probable Number Test

Product Name: Quanti-Tray® & Quanti-Tray®/2000 (Product #WQT100, WQT-2K)

Test Type: Most probable number (MPN)

Product Description: The Quanti-Tray and Quanti-Tray/2000 tests for *E. coli* and coliform bacteria using a plastic, sterile, disposable tray designed for Colilert, Colilert-18 or Colisure culture media.

The Quanti-Tray uses the MPN approach to determine the number of bacteria by dividing a 100 mL water sample into 51 wells. After incubation, the number of positive wells can be converted to an MPN. The Quanti-Tray provides bacterial counts from 1–200/100 (without dilutions).

The Quanti-Tray/2000 is based on the same statistical model as the traditional 15-tube serial dilution. With the Quanti-Tray/2000, the sample is automatically divided into 97 wells of two different sizes by the Quanti-Tray® Sealer and dilution is not required. After incubation, the Quanti-Tray/2000 provides bacterial counts from 1–2,419/100 mL.

Manufacturer: IDEXX Laboratories, Inc.
One IDEXX Drive
Westbrook, Maine 04092 USA
Tel: +1-207-556-4496 or 1-800-321-0207
Fax: +1-207-556-4630
Email: water@idexx.com
Website: www.idexx.com

Availability: USA and international

Cost: 15% discount available for educational and nonprofit research aid work organizations based in Canada and USA.

Catalogue Number	Manufacturing Number	Product Description	Price (US\$)
WP020I	98-12972-00	Colilert for 100 mL Sample, 20-pack	\$127
WP100I	98-27163-00	Colilert for 100 mL Sample, 100-pack	\$567
WP200I	98-12973-00	Colilert for 100 mL Sample, 200-pack	\$1,004
WQT100	98-21378-00	Quanti-Trays, 100-pack (0-200 MPN)	\$127
WQT-2K	98-21675-00	Quanti-Trays/2000, 200-pack (0-2,419 MPN)	\$173
WQTS2X-115	99-10893-01	IDEXX 110 Volt Quanti-Tray Sealer	\$4,200
WQTS2X-230	99-10896-01	IDEXX 220 Volt Quanti-Tray Sealer	\$4,200
WL200	98-06423-00	4-Watt Pocket UV Light	\$39

Storage: The shelf life is up to 3 years from the date of manufacture. When storing opened bags of trays, fold over the opened end of the bag and seal with tape.

Drinking Water Quality Testing: Microbiological Product Sheet: Most Probable Number Test

Maintenance: Trays are disposed after use.

Other Necessary Products: Incubator, Colilert culture media, Quanti-Tray Sealer, UV light for reading *E. coli* results



Quanti-Tray/2000 (Credit: IDEXX)

CAWST (Centre for Affordable Water and Sanitation Technology)
Calgary, Alberta, Canada
Website: www.cawst.org Email: resources@cawst.org
Wellness through Water.... Empowering People Globally
Last Update: October 2013

This document is open content. You are free to:



- Share – to copy, distribute and transmit this document
- Remix – to adapt this document



Under the following conditions:

- Attribution. You must give credit to CAWST as the original source of the document. Please include our website: www.cawst.org

CAWST does not assume any responsibility for and makes no warranty with respect to the quality of the product described in this document.



Drinking Water Quality Testing: Microbiological Product Sheet: Membrane Filter Unit

Product Name: Nalgene® Analytical Filter Unit

Test Type: Membrane filtration

Product Description: This is an individually wrapped, pre-assembled, pre-sterilized, and disposable filter apparatus. The filter consists of a polypropylene upper chamber to pour the sample water into and a polystyrene lower chamber to collect the filtered water. The filter apparatus is meant to be for single use, but it can be re-used by sterilizing with an alcohol wipe (with an increased chance of cross-contamination). Filter apparatus includes upper and lower chambers with reference mark at 100 mL; removable, 47mm Triton™-free cellulose nitrate (CN) membranes, (0.45 µm pore size); cellulosic support pad; cellulosic vent plug side arm; quick-disconnect tubing adapter; and blue support plate.

Manufacturer: Nalge Nunc International Corporation
75 Panorama Creek Drive
Rochester, NY
14625, USA
Email: web_master@nalgene.com

Distributor: Various distributors in the USA

ThermoFisher Scientific
3970 John's Creek Ct. Ste 500
Suwanee, GA
30024, USA
Tel: 1-800-955-5090 (In the United States)
Tel: +1-770-871-4725 (Outside the United States)
Fax: +1-770-871-4726
Email: exports@thermofisher.com

Availability: USA and international

Cost: Approximately US\$195.00 per 12 filters

Other Necessary Products: Vacuum pump



Nalgene® Analytical Filter Units (Credit: Nalgene)

Drinking Water Quality Testing: Microbiological Product Sheet: Membrane Filter Unit

CAWST (Centre for Affordable Water and Sanitation Technology)
Calgary, Alberta, Canada
Website: www.cawst.org Email: resources@caust.org
Wellness through Water.... Empowering People Globally
Last Update: October 2013

This document is open content. You are free to:



- Share – to copy, distribute and transmit this document
- Remix – to adapt this document



Under the following conditions:

- Attribution. You must give credit to CAWST as the original source of the document. Please include our website: www.cawst.org

CAWST does not assume any responsibility for and makes no warranty with respect to the quality of the product described in this document.



Drinking Water Quality Testing: Microbiological Product Sheet: Petri Dishes

Product Name:	Petri Dishes
Test Type:	Membrane filtration
Product Description:	<p>Petri dishes come in various types:</p> <ul style="list-style-type: none">• Aluminum, glass (Pyrex) or plastic (polystyrene, polypropylene)• Re-usable (polypropylene and aluminum) or pre-sterilized and disposable (polystyrene)• Some are sold with absorbent pads for direct use with liquid culture media or are already impregnated with dehydrated culture media• Plastic dishes (50-55 mm diameter by 9-12 mm height) tend to be taller than the aluminum ones (50 mm diameter by 8 mm height), so they are easier to use with liquid culture media
Manufacturers:	There are many manufacturers worldwide of plastic Petri dishes and they can usually be bought locally. Aluminum Petri dishes are more difficult to obtain - try Wagtech and Delagua (See Product Sheets on Portable Test Kits).
Availability:	International
Cost:	Varies depending on manufacturer: US\$0.25-0.55 per dish (plastic), approximately US\$2.70 per dish (aluminum)
Other Necessary Products:	Absorbent pads, membrane filters, culture media



Disposable Polystyrene Petri Dishes (Credit: Hach)

Drinking Water Quality Testing: Microbiological Product Sheet: Petri Dishes

CAWST (Centre for Affordable Water and Sanitation Technology)
Calgary, Alberta, Canada
Website: www.cawst.org Email: resources@cawst.org
Wellness through Water.... Empowering People Globally
Last Update: October 2013

This document is open content. You are free to:



- Share – to copy, distribute and transmit this document
- Remix – to adapt this document



Under the following conditions:

- Attribution. You must give credit to CAWST as the original source of the document. Please include our website: www.cawst.org

CAWST does not assume any responsibility for and makes no warranty with respect to the quality of the product described in this document.



Drinking Water Quality Testing: Physical Product Sheet: Turbidimeter

Product Name:	Turbidimeter
Test Type:	Turbidity
Product Description:	This turbidimeter is operated by a battery or power supply and it gives the digital reading of the turbidity level in nephelometric turbidity units (NTU). It has the capacity to measure turbidity levels from 0-1,000 NTU and is useful to measure water with turbidity less than 10 NTU, which is difficult to measure with a turbidity tube. A turbidimeter gives more accurate results, although it is more expensive and vulnerable to damage. Includes calibration kit and carrying case.
Manufacturer:	Palintest Ltd Palintest House, Kingsway, Team Valley, Gateshead, Tyne and Wear United Kingdom, NE11 0NS Tel: +44 (0) 191 491 0808 Fax: +44 (0) 191 482 5372 Email: export@palintest.com Website: www.palintest.com
Distributors:	Palintest has regional offices official agents and distributors serving customers in over 90 countries Email: export@palintest.com
Availability:	UK and international
Cost:	Need to contact Palintest
Storage:	Store in a dry location and ensure that a minimal amount of dust and/or debris will be able to settle on the optics of the turbidimeter.
Maintenance:	Needs to be calibrated and cleaned according to manufacturer's instructions. Water sample vials also need to be cleaned regularly. Scratches, fingerprints, dirt, and water droplets on the sample vial or inside the sample well can cause stray light interference leading to inaccurate results.



Turbidimeter (Credit: Palintest)

Drinking Water Quality Testing: Physical Product Sheet: Turbidimeter

CAWST (Centre for Affordable Water and Sanitation Technology)
Calgary, Alberta, Canada
Website: www.cawst.org Email: resources@cawst.org
Wellness through Water.... Empowering People Globally
Last Update: October 2013

This document is open content. You are free to:



- Share – to copy, distribute and transmit this document
- Remix – to adapt this document



Under the following conditions:

- Attribution. You must give credit to CAWST as the original source of the document. Please include our website: www.cawst.org

CAWST does not assume any responsibility for and makes no warranty with respect to the quality of the product described in this document.



Drinking Water Quality Testing: Physical Product Sheet: Turbidity Tube

Product Name: Turbidity Tube

Test Type: Turbidity

Product Description: A turbidity tube is an easy and relatively inexpensive way to visually estimate turbidity using nephelometric turbidity units (NTU). It can measure from 0-2,000 NTU, but it is harder to read levels less than 10 NTU.

Turbidity tubes are made of plastic and usually come in two or three parts that easily fit together. It is practical for field testing since it is very portable and does not need batteries or replacement parts.

Manufacturers: Palintest and Delagua include a turbidity tube as part of their portable water testing kits (see Product Sheets on Portable Test Kits). Delagua also sells turbidity tubes separately.

DelAgua Water Testing Limited
Unit 2, The Old Dairy
Church Lane
Lower Fyfield
Marlborough
SN8 1PX, United Kingdom
Tel : +44 (0) 1672 861 198
Fax: +44 (0) 1672 861 724
Email: info@delagua.org
Web: www.delagua.org/products/details/10713-Turbidity-Tubes-pair

Availability: UK and international

Cost: Approximately US\$115.00

Maintenance: Rinse with clean water after use to remove any dirt



Delagua turbidity tube (Credit: Delagua)



Wagtech turbidity tube (Credit: Palintest)

Drinking Water Quality Testing: Physical Product Sheet: Turbidity Tube

CAWST (Centre for Affordable Water and Sanitation Technology)
Calgary, Alberta, Canada
Website: www.cawst.org Email: resources@cawst.org
Wellness through Water.... Empowering People Globally
Last Update: October 2013

This document is open content. You are free to:



- Share – to copy, distribute and transmit this document
- Remix – to adapt this document



Under the following conditions:

- Attribution. You must give credit to CAWST as the original source of the document.
Please include our website: www.cawst.org

CAWST does not assume any responsibility for and makes no warranty with respect to the quality of the product described in this document.



Drinking Water Quality Testing: Microbiological, Physical, Chemical

Product Sheet: Portable Test Kit

Product Name:	DelAgua Water Testing Kits (various)
Test Type:	Microbiological, chemical, and physical parameters
Product Description:	<p>The DelAgua Water Testing Kit was developed by scientists at the University of Surrey in collaboration with colleagues at Oxfam. The kit is designed for water quality testing in difficult situations or remote areas where laboratory facilities do not exist. The kit is designed for use in the field, but may also be used in a laboratory or other permanent location.</p> <p>The kit comes in different versions (e.g., Bacteriological Kit #1, Kit #2, Kit#3, Single Incubator, Dual Incubator, Lightweight Incubator) that are suitable for various contexts and budgets. The kits can be supplied with a range of equipment and products that will increase the scope of testing for chemical and physical parameters.</p> <p>The Single Incubator Kit (Product # DWT 10098) is designed to carry out five water quality tests including membrane filtration for microbiological quality, turbidity, free chlorine, total chlorine, and pH. The kit can test for different indicator organisms including thermotolerant coliforms, <i>E. coli</i>, cholera, and salmonella. The incubator is built with an internal battery and is capable of up to 5 incubation cycles between recharges. Additional equipment can be included on request to test for chemicals that may be of local importance. The kit includes consumable products needed for 200 tests.</p>
Manufacturer:	DelAgua Water Testing Limited Unit 2, The Old Dairy Church Lane Lower Fyfield Marlborough SN8 1PX, United Kingdom Tel : +44 (0) 1672 861 198 Fax: +44 (0) 1672 861 724 Email: info@delagua.org
Distributors:	Various distributors worldwide, contact sales@delagua.org
Availability:	UK and international
Cost:	Single Incubator Kit: £2,312 (approximately US\$3,710) (excluding VAT). Contact Delagua for quotes in Euro and US dollars.
Storage:	The kit and components must remain dry.

Drinking Water Quality Testing: Microbiological, Physical, Chemical

Product Sheet: Portable Test Kit

Maintenance:

Weekly:

1. Wash, rinse and dry the filtration apparatus
2. Apply a smear of silicone grease to the black rubber O-ring
3. Charge the internal battery fully at the end of each week

Monthly:

Weekly maintenance, plus:

1. Check the incubator temperature and recalibrate if necessary
2. Clean all components of the kit, including the case
3. Check all components for damage that may affect operation

Other Necessary Products:

Sterilization capability for microbiological waste disposal. Heat source able to sustain high heat to prepare culture media.



DelAgua Portable Test Kit (Credit: Delagua)

CAWST (Centre for Affordable Water and Sanitation Technology)

Calgary, Alberta, Canada

Website: www.cawst.org Email: resources@cawst.org

Wellness through Water.... Empowering People Globally

Last Update: October 2013

This document is open content. You are free to:



- Share – to copy, distribute and transmit this document
- Remix – to adapt this document



Under the following conditions:

- Attribution. You must give credit to CAWST as the original source of the document. Please include our website: www.cawst.org

CAWST does not assume any responsibility for and makes no warranty with respect to the quality of the product described in this document.



Drinking Water Quality Testing: Microbiological Product Sheet: Portable Test Kit

Product Name:	ColiQuant MF (Code 3-0035)
Test Type:	Membrane filtration for <i>E. coli</i> and total coliforms
Product Description:	ColiQuant MF is a portable test kit that includes a plastic membrane filtration apparatus, Petri dishes, nutrient pads, filter paper, and culture media (Coliscan MF manufactured by Micrology Laboratories – see Culture Media Product Sheet for more information). The filter apparatus is disinfected with alcohol wipes (not by burning methanol) which may leave some contamination. 20 tests can be performed per kit and refill packages are available (refill does not include membrane filtration apparatus).
Manufacturer(s):	LaMotte Company 802 Washington Ave PO Box 329 Chestertown, Maryland 21620, USA Tel: 1-800-344-3100 or +1-410-778-3100 Fax: +1-410-778-6394 Email: sales@lamotte.com
Distributors(s):	Contact the international sales department: intl@lamotte.com
Availability	United States and international
Cost:	US\$97.88 per 20 test kit. Refills available for US\$64.90 per 20.
Storage:	Store in a dry location at room temperature
Maintenance:	None
Other Necessary Products:	Incubator, forceps, permanent marker, alcohol wipes to sterilize the filtration apparatus



ColiQuant MF (Credit: Global Scientific Supply)

Drinking Water Quality Testing: Microbiological Product Sheet: Portable Test Kit

CAWST (Centre for Affordable Water and Sanitation Technology)
Calgary, Alberta, Canada
Website: www.cawst.org Email: resources@caust.org
Wellness through Water.... Empowering People Globally
Last Update: October 2013

This document is open content. You are free to:



- Share – to copy, distribute and transmit this document
- Remix – to adapt this document



Under the following conditions:

- Attribution. You must give credit to CAWST as the original source of the document. Please include our website: www.cawst.org

CAWST does not assume any responsibility for and makes no warranty with respect to the quality of the product described in this document.



Drinking Water Quality Testing: Microbiological, Physical, Chemical

Product Sheet: Portable Test Kit

Product Name:	Portable Water Testing Kits (various)
Test Type:	Microbiological, chemical, and physical parameters
Product Description:	<p>Palintest portable kits are designed for water quality testing in difficult situations or remote areas where laboratory facilities do not exist. The kit are designed for use in the field, but may also be used in a laboratory or other permanent location.</p> <p>Palintest manufactures different portable test kits suitable for various contexts and budgets, including:</p> <ul style="list-style-type: none">• Potatest®: Emergency Rapid Response Kit• Potakit®: Intermediate Low-Budget Testing Kit• Potalab®: Advanced Long-Term Monitoring Kit <p>Microbiological testing is carried out by using membrane filtration to test for thermotolerant (fecal) and total coliforms. The portable incubator can be powered via external rechargeable battery, AC mains operation, DC operation via vehicle lighter socket, or solar power.</p> <p>Test kits use long-life, low-cost reagents and consumables available locally through Palintest in-country representatives. The kits can also be supplied with a range of equipment and products that will increase the scope of testing for chemical and physical parameters.</p>
Manufacturer:	<p>Palintest Ltd Palintest House, Kingsway, Team Valley, Gateshead, Tyne and Wear United Kingdom, NE11 0NS Tel: +44 (0) 191 491 0808 Fax: +44 (0) 191 482 5372 Email: export@palintest.com Website: www.palintest.com</p>
Distributors:	<p>Palintest has regional offices official agents and distributors serving customers in over 90 countries Email: export@palintest.com</p>
Availability:	UK and international
Cost:	<p>Potatest® = £1,250 (approximately US\$2,028) Potakit® = £2,250 (approximately US\$3,650) Potalab® = £4,950 (approximately US\$8,030)</p>

Drinking Water Quality Testing: Microbiological, Physical, Chemical

Product Sheet: Portable Test Kit

Maintenance: Regular calibration of incubator and digital equipment, regular cleaning

Other Necessary Products: An electrical source, sterilization capability for microbiological waste disposal, heat source (lighter) may be required



Left: Potatest®: Emergency Rapid Response Kit, Right: Potalab®: Advanced Long-Term Monitoring Kit (Credit: Palintest)

CAWST (Centre for Affordable Water and Sanitation Technology)
Calgary, Alberta, Canada
Website: www.cawst.org Email: resources@cawst.org
Wellness through Water.... Empowering People Globally
Last Update: October 2013

This document is open content. You are free to:



- Share – to copy, distribute and transmit this document
- Remix – to adapt this document



Under the following conditions:

- Attribution. You must give credit to CAWST as the original source of the document. Please include our website: www.cawst.org

CAWST does not assume any responsibility for and makes no warranty with respect to the quality of the product described in this document.



Drinking Water Quality Testing: Water Sampling Product Sheet: Water Sample Bag

Product Name:	Whirl-Pak® Bags
Test Type:	Water sample bag
Product Description:	The Whirl-Pak® bag is a sterile plastic bag that is sealed with a tab closure. The bags are meant for one-time use and are to be disposed afterwards. They are available in a variety of sizes ranging from 29 mL to over 5 L.
Manufacturer(s):	Nasco 901 Janesville Avenue Fort Atkinson, WI 53538, USA
Distributor(s):	USA and Canadian Customers: Tel: 1-800-558-9595 For all other international inquiries: Tel: +1-920-563-2446 Email: export@eNasco.com Website: www.enasco.com/page/contact
Availability:	US and international
Cost:	US\$68.45 per 500 bags
Storage:	Should not be used for water temperatures above 82°C
Other Necessary Products:	Permanent marker for writing label on bags



Whirl-Pak® Bag (Credit: Nasco)

Drinking Water Quality Testing: Water Sampling

Product Sheet: Sample Bag



Step 1

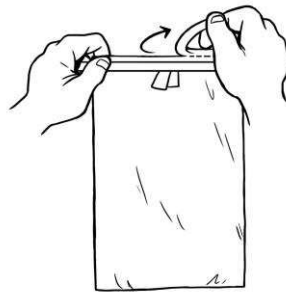

Step 2

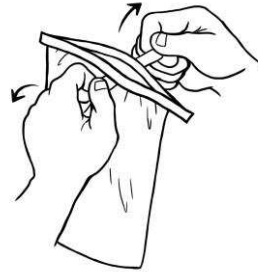

Step 3

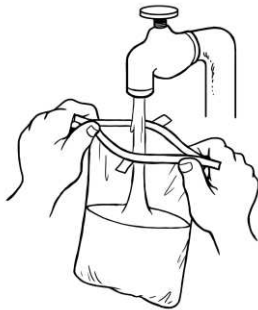

Step 4



Step 5

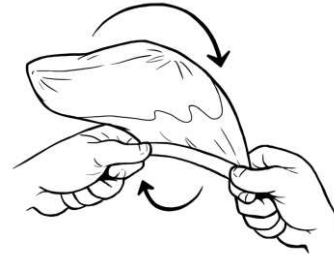

Step 6



Step 7

CAWST (Centre for Affordable Water and Sanitation Technology)

Calgary, Alberta, Canada

Website: www.cawst.org Email: resources@cawst.org

Wellness through Water.... Empowering People Globally

Last Update: October 2013

This document is open content. You are free to:



- Share – to copy, distribute and transmit this document
- Remix – to adapt this document



Under the following conditions:

- Attribution. You must give credit to CAWST as the original source of the document. Please include our website: www.cawst.org

CAWST does not assume any responsibility for and makes no warranty with respect to the quality of the product described in this document.



Introduction to Drinking Water Quality Testing

Appendix 3: Chemical Fact Sheets

Chemical Parameters of Drinking Water Fact Sheet: Arsenic

Sources

Arsenic can naturally occur in groundwater and some surface water. It is one of the greatest chemical problems in developing countries. The World Health Organization (WHO) considers arsenic to be one of the chemicals of greatest health concern in some natural waters and a high priority for testing in drinking water sources (WHO, 2011; WHO, 2012).

High levels of arsenic can be found naturally in water from deep wells in over 70 countries, including India, Nepal, Bangladesh, Indonesia, Cambodia, Vietnam, Lao PDR, Mexico, Nicaragua, El Salvador, and Brazil. In South Asia alone, it is estimated that 60 to 100 million people are affected by unsafe levels of arsenic in their drinking water. Bangladesh is the most severely affected, where 35 to 60 million of its 130 million people are exposed to arsenic contaminated water. It is possible that arsenic may be found in other locations as more water quality testing is done.

Potential Health Effects

Arsenic is poisonous, so if people drink water or eat food contaminated with arsenic for several years, they develop chronic health problems called arsenicosis.

Melanosis is the first symptom of drinking arsenic contaminated water over a few years. Melanosis is light or dark spots on people's skin, often on the chest, back, or palms. The next step is that hardening skin bulges develop on people's palms and feet – called keratosis. Drinking high amounts of arsenic for a longer time may cause cancer in the lungs, bladder, kidney, skin, liver, and prostate. Arsenic may also cause vascular diseases, neurological effects, and infant developmental defects.

Arsenicosis can be partially reversed and treated in the early stages by making sure people stop drinking arsenic contaminated water and by improving their nutrition. There is currently no effective cure for arsenic poisoning. The only prevention is to drink water that has safe levels of arsenic.

According to the United Nations Development Program (2006), the projected human costs over the next 50 years include 300,000 deaths from cancer and 2.5 million cases of arsenic poisoning.

World Health Organization Guidelines

It is difficult to measure arsenic levels below 1-10 µg/L, and removing arsenic in drinking water to concentrations below 10 µg/L is difficult in many circumstances. In view of the practical difficulties in testing and removing arsenic, the WHO (2011) suggests that drinking water should have less than 10 µg/L of arsenic (10 µg/L is the same as 0.01 mg/L, 0.01 ppm or 10 ppb.)

WHO Guideline for Arsenic in Drinking Water <10 µg/L

Chemical Parameters of Drinking Water

Fact Sheet: Arsenic

Many countries have their own standards which are less strict than the WHO Guidelines, ranging from 25 mg/L to 50 µg/L (25-50 ppb). Many Southeast Asian countries that have an arsenic problem have adopted a temporary standard of 50 µg/L because it is difficult to test accurately to 10 µg/L and to treat water to meet that level.

Water Quality Testing Methods

Testing for arsenic in drinking water, especially at the µg/L level, is difficult. There are no simple paper test strip or colour disc comparator field kits available. Arsenic testing used to be only possible in a laboratory. However, as a result of the discovery of significant arsenic contamination of groundwater in Asia and elsewhere, a variety of portable test kits are now available. All of these rely on the Gutzeit method, which consists of several steps (UNICEF, 2008).

Most commercially available portable test kits typically provide colour reference charts, with reported detection limits around 10 µg/L. However, evaluations have shown that the results are semi-quantitative at best, especially at lower levels (<100 µg/L). The kits are most effectively used in a positive/negative format with a reference value of 50 µg/L, which is the drinking water standard in many countries. At this level, most samples containing 50-99 µg/L are identified as positive, and nearly all samples containing 100 µg/L or more result in positive test results, though the quantitative result may be incorrect (UNICEF, 2008).

However, in recent years manufacturers of portable test kits have modified designs in an effort to lower the detection limit for arsenic. The newer kits are probably still not capable of reliably quantifying arsenic at such low levels, but should have lower false negative rates when used in a positive/negative format (UNICEF, 2008).

Information about commercially available portable test kits are provided in CAWST's Drinking Water Quality Testing Product Sheets.

Household Water Treatment Options

One way to deal with arsenic in groundwater is to use a different source of drinking water, such as rainwater or surface water. Some people collect and store their rainwater and use it for drinking and cooking instead of arsenic contaminated groundwater. If people change to drinking surface water, they will probably need to treat the water to remove turbidity and pathogens.

If people are unable to change to a water source that does not have arsenic, there are various household water treatment options that have been developed to remove arsenic from water. Each technology has advantages and limitations. Many of these technologies are being used in Bangladesh where the arsenic problem is widespread. See CAWST's Household Water Treatment for Arsenic Removal Fact Sheets for more information on the different technologies.

The following illustration shows the different mitigation options for arsenic in drinking water.

Chemical Parameters of Drinking Water

Fact Sheet: Arsenic

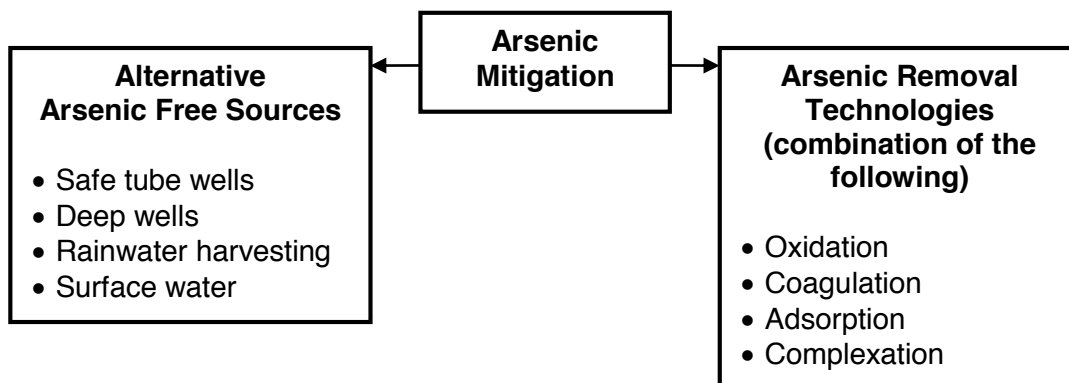

References

United Nations Development Program (2006). Human Development Report 2006: Beyond Scarcity: Power, Poverty and the Global Water Crisis. New York, USA. Available at: <http://hdr.undp.org/en/media/HDR06-complete.pdf>

UNICEF (2008). UNICEF Handbook on Water Quality. UNICEF, New York, USA. Available at: www.unicef.org/wash/files/WQ_Handbook_final_signed_16_April_2008.pdf

World Health Organization (2011). Guidelines for Drinking-Water Quality, Fourth Edition. WHO, Geneva, Switzerland. Available at: www.who.int/water_sanitation_health/dwq/secondaddendum20081119.pdf

World Health Organization (2012). Rapid Assessment of Drinking-Water Quality: A Handbook for Implementation. WHO, Geneva, Switzerland. Available at: www.who.int/water_sanitation_health/publications/2012/rapid_assessment/en/index.html

CAWST (Centre for Affordable Water and Sanitation Technology)
Calgary, Alberta, Canada
Website: www.cawst.org Email: resources@cawst.org
Wellness through Water.... Empowering People Globally
Last Update: October 2013

This document is open content. You are free to:



- Share – to copy, distribute and transmit this document
- Remix – to adapt this document



Under the following conditions:

- Attribution. You must give credit to CAWST as the original source of the document. Please include our website: www.cawst.org

CAWST and its directors, employees, contractors and volunteers do not assume any responsibility for and make no warranty with respect to the results that may be obtained from the use of the information provided.



Chemical Parameters of Drinking Water Fact Sheet: Chlorine

Sources

Chlorine is produced in large amounts and widely used both industrially and domestically as an important disinfectant and bleach. In particular, it is the most commonly used chemical disinfectant in drinking water treatment and is widely used in the disinfection of swimming pools.

Chlorine is widely used to disinfect drinking water as the final step in the water treatment process. Chemical disinfection using chlorine has the benefits of being relatively quick, simple, and inexpensive. It also allows a residual amount of chlorine to remain in the water to provide some protection against subsequent contamination.

Three things can happen when chlorine is added to water:

1. Some chlorine reacts with the organic matter and pathogens and kills them. This portion of the added chlorine is said to be consumed.
2. Some chlorine reacts with other organic matter and forms new chlorine compounds. This portion is called combined chlorine.
3. Excess chlorine that is not consumed or combined and remains in the water is known as free residual chlorine (FRC).

The objective of chlorination is to add enough chlorine to leave 0.2-0.5 mg/L FRC after half an hour contact time. Factors influencing the effectiveness of chlorine as a disinfectant are concentration, contact time, pH, temperature, and the presence of organic matter in the water. All of these factors can vary day to day and in different seasons.

Potential Health Effects

Drinking water with high concentrations of chlorine is not known to cause specific adverse health effects. Chlorine, however, can change the taste and smell of water and it may cause people to not use it and to choose another, possibly contaminated, water source instead. People often complain of a strong taste and smell when the FRC concentration is between 0.6-1.0 mg/L (UNICEF, 2008).

World Health Organization Guidelines

There are no specific adverse health effects of exposure to free chlorine, but the World Health Organization (WHO) has conservatively set a guideline value of 5 mg/L, which is well above the taste and odour threshold (WHO, 2011). Most people are able to taste or smell chlorine in drinking water at concentrations well below 5 mg/L, and some at levels as low as 0.3 mg/L.

For effective disinfection, there should be a residual concentration of free chlorine of ≥ 0.5 mg/L after at least 30 minutes contact time at pH < 8.0 . A chlorine residual should be maintained throughout the distribution system. At the point of delivery, the minimum residual concentration of free chlorine should be 0.2 mg/L (WHO, 2011).

Chemical Parameters of Drinking Water Fact Sheet: Chlorine

WHO Guideline for Chlorine in Drinking Water <5 mg/L

Water Quality Testing Methods

On-site testing is essential for measuring FRC since the concentration can change rapidly during transport and storage (WHO, 2011). Portable digital photometers are available from various commercial manufacturers. These can provide reliable and quantitative measurements of chlorine (UNICEF, 2008). Chlorine can also be easily measured using pool test kits, test strips, or a colour disc comparator.

Information about commercially available portable test kits are provided in CAWST's Drinking Water Quality Testing Product Sheets.

Household Water Treatment Options

Generally, people do not try to remove chlorine from their drinking water. Rather, it is often used to treat water to make it safe to drink. However, some people are sensitive to the taste and smell of chlorine in their drinking water. A practical household option to reduce the chlorine level is simply letting the water stand in a container for a period of time ranging from a few hours to a few days so that the chlorine dissipates. Another quick option is to shake a bottle of water to help the chlorine dissipate faster.

References

UNICEF (2008). UNICEF Handbook on Water Quality. UNICEF, New York, USA. Available at: www.unicef.org/wes/files/WQ_Handbook_final_signed_16_April_2008.pdf

World Health Organization (2011). Guidelines for Drinking-Water Quality, Fourth Edition. WHO, Geneva, Switzerland. Available at: www.who.int/water_sanitation_health/dwq/secondaddendum20081119.pdf

CAWST (Centre for Affordable Water and Sanitation Technology)
Calgary, Alberta, Canada
Website: www.cawst.org Email: resources@cawst.org
Wellness through Water.... Empowering People Globally
Last Update: October 2013

This document is open content. You are free to:



- Share – to copy, distribute and transmit this document
- Remix – to adapt this document



Under the following conditions:

- Attribution. You must give credit to CAWST as the original source of the document. Please include our website: www.cawst.org

CAWST and its directors, employees, contractors and volunteers do not assume any responsibility for and make no warranty with respect to the results that may be obtained from the use of the information provided.



Chemical Parameters of Drinking Water Fact Sheet: Fluoride

Sources

Fluoride can naturally occur in groundwater and some surface water. Drinking water is normally the major source of fluoride exposure (Fawell et al., 2006). However, in some regions, food and burning high fluoride coal can also be major contributors of fluoride in the environment.

High levels of fluoride can be found naturally in many areas of the world. The most well-known and documented area associated with volcanic activity follows the East African Rift from the Jordan valley down through Sudan, Ethiopia, Uganda, Kenya and Tanzania. High groundwater fluoride concentrations have been reported in India, Pakistan, West Africa, Thailand, China, Sri Lanka, and Southern Africa. Another region extends from Iraq and Iran through Syria and Turkey to the Mediterranean region, including from Algeria to Morocco. Other regions include the southern parts of the USA, southern Europe, and the southern parts of the former USSR (Fawell et al., 2006).

Potential Health Effects

A small amount of fluoride in water is generally good for strengthening people's teeth and preventing decay. Fluoride is often added to municipal water systems and certain consumer products (such as toothpaste and mouthwash) to protect teeth.

However, consuming fluoride at higher amounts over time can cause dental fluorosis and damage to people's teeth by staining and pitting. Over many years, fluoride can build up in people's bones, leading to skeletal fluorosis characterized by stiffness and joint pain. In severe cases, fluoride can cause changes to the bone structure and crippling effects. Infants and young children are most at risk from high amounts of fluoride since their bodies are still growing and developing.

There is currently no effective cure for fluorosis – the only prevention is to drink water that has safe levels of fluoride.

World Health Organization Guidelines

There is evidence that drinking water with fluoride levels of 0.5-1.0 mg/L can protect teeth (WHO, 2011). Many cities around the world add fluoride to their drinking water to reach this level.

Higher amounts of fluoride between 1.5-4.0 mg/L can cause dental fluorosis. Very high amounts of fluoride greater than 10.0 mg/L can lead to skeletal fluorosis. This is why the World Health Organization (2011) suggests that drinking water should not have more than 1.5 mg/L of fluoride (1.5 mg/L is the same as 1.5 ppm, 1,500 µg/L or 1,500 ppb).

WHO Guideline for Fluoride in Drinking Water <1.5 mg/L

Chemical Parameters of Drinking Water

Fact Sheet: Fluoride

Water Quality Testing Methods

Fluoride can be tested using a commercial laboratory or portable test kit. Laboratories commonly use an ion-selective electrode or a colorimetric procedure. Portable digital colorimeters are available from various commercial manufacturers. These can provide reliable and quantitative measurements of fluoride (UNICEF, 2008). Fluoride can also be measured using a colour disc comparator; however, this is a less accurate test method than using a digital colorimeter.

Information about commercially available fluoride test kits are provided in CAWST's Drinking Water Quality Testing Product Sheets.

Household Water Treatment Options

The best way to deal with fluoride in groundwater is to find a different source of drinking water, such as rainwater or surface water. Some people collect and store their rainwater during the rainy season and use it for drinking or to dilute their groundwater during the rest of the year. This helps to lower the amount of fluoride in their water and make it safer to drink. If people change to drinking surface water, they will probably need to treat the water to remove turbidity and pathogens.

Many of the areas that have fluoride contamination are arid and alternative sources of water are not available. There are emerging household water treatment technologies that are able to remove fluoride from drinking water. More research is needed to find simple, affordable and locally available technologies that can be easily used by households. See CAWST's Household Water Treatment for Fluoride Removal Fact Sheets for more information on the different technologies.

The following illustration shows the different mitigation options for fluoride in drinking water.

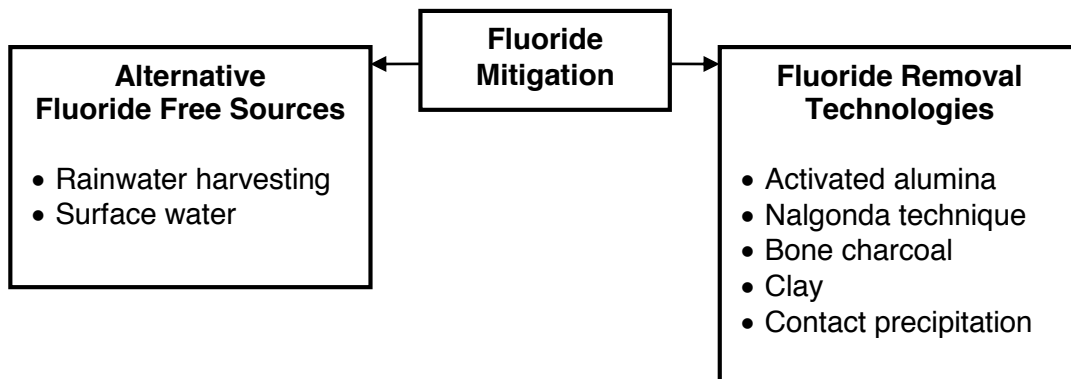

Chemical Parameters of Drinking Water

Fact Sheet: Fluoride

References

Fawell, J., Bailey, K., Chilton, J., Dahi, E., Fewtrell, L. and Y. Magara (2006). Fluoride in Drinking-water. World Health Organization. IWA Publishing, London, UK. Available at: www.who.int/water_sanitation_health/publications/fluoride_drinking_water/en/index.html

UNICEF (2008). UNICEF Handbook on Water Quality. UNICEF, New York, USA. Available at: www.unicef.org/wash/files/WQ_Handbook_final_signed_16_April_2008.pdf

World Health Organization (2011). Guidelines for Drinking-Water Quality, Fourth Edition. WHO, Geneva, Switzerland. Available at: www.who.int/water_sanitation_health/dwg/secondaddendum20081119.pdf

CAWST (Centre for Affordable Water and Sanitation Technology)
Calgary, Alberta, Canada
Website: www.cawst.org Email: resources@cawst.org
Wellness through Water.... Empowering People Globally
Last Update: October 2013

This document is open content. You are free to:



- Share – to copy, distribute and transmit this document
- Remix – to adapt this document



Under the following conditions:

- Attribution. You must give credit to CAWST as the original source of the document. Please include our website: www.cawst.org

CAWST and its directors, employees, contractors and volunteers do not assume any responsibility for and make no warranty with respect to the results that may be obtained from the use of the information provided.



Chemical Parameters of Drinking Water Fact Sheet: Iron

Sources

Iron can be naturally found in groundwater and some surface water (such as creeks, rivers and some shallow dug wells). There are some areas of the world that have naturally high amounts of iron in their groundwater. Iron can also be found in drinking water that is passed through rusty steel or cast iron pipes.

Iron can come in two forms in water: dissolved and suspended. If groundwater comes from a deep tube well, the iron may be dissolved and not visible. However, once the iron is exposed to air, it usually turns the water a black or orange colour. If surface water has iron in it, it will be a red-orange colour from the iron that is suspended in the water.

Iron is a nuisance – high levels can cause an objectionable colour and taste and can stain cooked food, water pipes, and laundry. Some types of bacteria use dissolved iron as an energy source and leave slimy red deposits that can clog water pipes.

Potential Health Effects

Drinking water with high concentrations of iron will not make people sick. Iron however, can change the colour and smell of water and it may cause people to not use it and choose another, possibly contaminated, water source instead.

World Health Organization Guidelines

The World Health Organization (WHO) does not have a suggested guideline for iron in drinking water since it does not have any adverse health effects (WHO, 2011).

Usually, people do not like the taste and smell of drinking water that has more than 0.3 mg/L of iron. Concentrations between 1.0-3.0 mg/L can be acceptable to people used to drinking anaerobic (low levels of oxygen) well water.

Iron levels above 0.3 mg/L can stain water pipes and clothes during washing.

The presence of iron may also lead to bacterial growth that can clog water pipes.

No WHO Guideline for Iron in Drinking Water

Water Quality Testing Methods

Iron can be tested using a commercial laboratory or portable test kit. Portable digital colorimeters and photometers are available from various commercial manufacturers. These can provide reliable and quantitative measurements of iron (UNICEF, 2008). Iron can also be measured using a colour disc comparator.

Chemical Parameters of Drinking Water

Fact Sheet: Iron

Information about commercially available portable test kits are provided in CAWST's Drinking Water Quality Testing Product Sheets.

Household Water Treatment Options

There are some different technology options that can be combined to help take iron out of drinking water, depending on the level of contamination. Practical household options include aeration to precipitate any dissolved iron, sedimentation, and then filtration to remove any iron particles that remain in suspension.

Removing suspended iron can be as simple as letting the water stand in a container for a period of time ranging from a few hours to a few days then decanting it, or by filtering the water through a cloth. The iron residue will need to be disposed.

Biosand or ceramic filters, which are designed primarily for pathogen removal, can also be used to remove some of the iron from drinking water. High levels of iron may cause these filters to clog more quickly, requiring more frequent maintenance which can reduce the efficiency of pathogen removal. In this case, it is recommended to sediment the water beforehand.

References

UNICEF (2008). UNICEF Handbook on Water Quality. UNICEF, New York, USA. Available at: www.unicef.org/wash/files/WQ_Handbook_final_signed_16_April_2008.pdf

World Health Organization (2011). Guidelines for Drinking-Water Quality, Fourth Edition. WHO, Geneva, Switzerland. Available at: www.who.int/water_sanitation_health/dwq/secondaddendum20081119.pdf

CAWST (Centre for Affordable Water and Sanitation Technology)
Calgary, Alberta, Canada
Website: www.cawst.org Email: resources@cawst.org
Wellness through Water.... Empowering People Globally
Last Update: October 2013

This document is open content. You are free to:



- Share – to copy, distribute and transmit this document
- Remix – to adapt this document



Under the following conditions:

- Attribution. You must give credit to CAWST as the original source of the document. Please include our website: www.cawst.org

CAWST and its directors, employees, contractors and volunteers do not assume any responsibility for and make no warranty with respect to the results that may be obtained from the use of the information provided.



Chemical Parameters of Drinking Water Fact Sheet: Manganese

Sources

Manganese can be naturally found in groundwater and surface water, and it usually occurs with iron. However, human activities may also cause manganese contamination in some areas.

Manganese can come in two forms in water: dissolved and suspended. If groundwater comes from a deep tube well, the manganese may be dissolved and not visible. In surface water, manganese can be dissolved or suspended. Water with high levels of suspended manganese usually has a black colour or black flakes in it.

High concentrations of manganese can turn water a black colour. It also causes an objectionable taste, stains water pipes and laundry, and forms coatings on water pipes. As well, some types of bacteria feed on manganese and leave black-brown deposits that can also clog pipes.

Potential Health Effects

People need small amounts of manganese to keep healthy, and food is the major source of manganese for people. However, too much manganese may also cause adverse neurological effects.

High levels of manganese can turn water a black colour and it may cause people to not use it and choose another, possibly contaminated, water source instead.

World Health Organization Guidelines

Manganese is not of health concern at levels causing acceptability problems in drinking water and there is no World Health Organization (WHO) guideline value (WHO, 2011).

Usually, people do not like the taste of drinking water that has more than 0.1 mg/L of manganese. Also, amounts above 0.1 mg/L can stain water pipes, clothes during washing, and food during cooking. Even levels of manganese at 0.2 mg/L may form black coatings on distribution pipes that come off into water as small black flakes.

The presence of manganese may also lead to bacterial growth that can clog water pipes.

No WHO Guideline since manganese is not of health concern at levels causing acceptability problems in drinking water

Water Quality Testing Methods

Manganese can be tested using a commercial laboratory or portable test kit. Portable digital colorimeters and photometers are available from various commercial manufacturers. These can provide reliable and quantitative measurements of manganese (UNICEF, 2008). Manganese can also be measured using a colour disc comparator.

Chemical Parameters of Drinking Water Fact Sheet: Manganese

Information about commercially available test kits are provided in CAWST's Drinking Water Quality Testing Product Sheets.

Household Water Treatment Options

Manganese treatment options are similar to iron; however, the removal rates are not as high. There are some different technology options that can be combined to help take manganese out of drinking water, depending on the level of contamination. Practical household options include aeration to precipitate any dissolved manganese, sedimentation, and then filtration to remove any manganese particles that remain in suspension.

Removing suspended manganese can be as simple as letting the water stand in a container for a period of time ranging from a few hours to a few days then decanting it, or by filtering the water through cloth. The manganese residue will need to be disposed in a safe location.

Biosand or ceramic filters, which are designed primarily for pathogen removal, can also be used to take out some of the manganese from drinking water. High levels of manganese may cause these filters to clog more quickly, requiring more frequent maintenance which can reduce the efficiency of pathogen removal. In this case, it is recommended to sediment the water beforehand.

References

UNICEF (2008). UNICEF Handbook on Water Quality. UNICEF, New York, USA. Available at: www.unicef.org/wash/files/WQ_Handbook_final_signed_16_April_2008.pdf

World Health Organization (2011). Guidelines for Drinking-Water Quality, Fourth Edition. WHO, Geneva, Switzerland. Available at: www.who.int/water_sanitation_health/dwg/secondaddendum20081119.pdf

CAWST (Centre for Affordable Water and Sanitation Technology)
Calgary, Alberta, Canada
Website: www.cawst.org Email: resources@cawst.org
Wellness through Water.... Empowering People Globally
Last Update: October 2013

This document is open content. You are free to:



- Share – to copy, distribute and transmit this document
- Remix – to adapt this document



Under the following conditions:

- Attribution. You must give credit to CAWST as the original source of the document. Please include our website: www.cawst.org

CAWST and its directors, employees, contractors and volunteers do not assume any responsibility for and make no warranty with respect to the results that may be obtained from the use of the information provided.



Chemical Parameters of Drinking Water Fact Sheet: Nitrate and Nitrite

Sources

Nitrate and nitrite are naturally occurring chemicals in the environment. Nitrate (NO_3^-) is an important plant nutrient and found at different concentrations in all plants. Nitrite (NO_2^-) is not usually found in significant concentrations in the environment, since nitrate is the more stable chemical.

Nitrate is commonly used in agricultural fertilizers, and nitrite is used as a food preservative, especially in processed meat.

Nitrate in groundwater and surface water is normally low, but can reach high levels if there is leaching or runoff from agricultural fertilizers or from human and animal feces. Nitrite is formed as a result of microbial activity in soil and the levels in water can vary.

Nitrite can also be formed in water distribution pipes by *Nitrosomonas* bacteria if the water is stagnant and without a lot of oxygen, or if chloramine is used to treat the drinking water and provide a residual disinfectant.

Potential Health Effects

High nitrate and nitrite levels can cause serious illness by acute exposure. The main health concern is methaemoglobinaemia, or blue baby syndrome, which occurs in infants that are bottle fed with formula prepared with drinking water. It causes them to have difficulty breathing and their skin turns blue from a lack of oxygen. It is a serious illness that can sometimes lead to death.

Babies with methaemoglobinaemia often also have gastrointestinal illness (e.g., diarrhea) at the same time. This is because high nitrate levels are often associated with higher levels of microbiological contamination from manure or sewage.

World Health Organization Guidelines

The World Health Organization (WHO) suggests that drinking water should have less than 50 mg/L of nitrate and 3 mg/L of nitrite to protect against methaemoglobinaemia in bottle fed infants (short-term exposure). In addition, the sum of the ratios of the concentrations of each to its guideline value should not exceed 1 (WHO, 2011).

For example, a drinking water sample contains 30 mg/L nitrate and 1.5 mg/L nitrite. Does the sum of the ratios of the concentrations exceed the guideline value?

$$\frac{30 \text{ mg/L nitrate (water sample)}}{50 \text{ mg/L nitrate (WHO guideline)}} = 0.6 \quad \frac{1.5 \text{ mg/L nitrite (water sample)}}{3 \text{ mg/L nitrite (WHO guideline)}} = 0.5$$

Add the ratio of the concentrations together: $0.6 + 0.5 = 1.1$

1.1 is greater than 1, so this drinking water sample exceeds the WHO guideline value.

Chemical Parameters of Drinking Water

Fact Sheet: Nitrate and Nitrite

In most countries, nitrate levels in surface water are not more than 10 mg/L, although nitrate levels in well water often exceed 50 mg/L. The WHO guideline was set specifically for bottle fed infants who are most vulnerable to nitrates and nitrites in drinking water. Therefore the guideline value is more than adequately protective for older children and adults (WHO, 2011).

WHO Guideline for Nitrate in Drinking Water <50 mg/L (short-term exposure)

WHO Guideline for Nitrite in Drinking Water <3 mg/L (short-term exposure)

Water Quality Testing Methods

Nitrate and nitrite can be tested using a commercial laboratory or portable test kit. Portable digital photometers are available from various commercial manufacturers. These can provide reliable and quantitative measurements of iron (UNICEF, 2008). Nitrate and nitrite can also be measured using test strips or a colour disc comparator.

Information about commercially available test kits are provided in CAWST's Drinking Water Quality Testing Product Sheets.

Household Water Treatment Options

The best way to deal with nitrate and nitrite in groundwater or surface water is to use a different source of drinking water, such as rainwater. Some people collect and store their rainwater and use it for drinking, cooking, and preparing baby formula. If people change their water source from groundwater to surface water, they will probably need to treat the surface water to remove turbidity and pathogens.

High nitrate levels are often associated with higher levels of microbiological contamination since the nitrates may have come from manure or sewage. If high levels of nitrate are detected, then people should also treat their water to remove the potential microbiological contamination.

The WHO (2011) suggests that high levels of nitrite may be reduced to acceptable levels by using chlorination.

References

UNICEF (2008). UNICEF Handbook on Water Quality. UNICEF, New York, USA. Available at: www.unicef.org/wash/files/WQ_Handbook_final_signed_16_April_2008.pdf

World Health Organization (2011). Guidelines for Drinking-Water Quality, Fourth Edition. WHO, Geneva, Switzerland. Available at: www.who.int/water_sanitation_health/dwq/secondaddendum20081119.pdf



Chemical Parameters of Drinking Water Fact Sheet: Nitrate and Nitrite

CAWST (Centre for Affordable Water and Sanitation Technology)
Calgary, Alberta, Canada
Website: www.cawst.org Email: resources@cawst.org
Wellness through Water.... Empowering People Globally
Last Update: October 2013

This document is open content. You are free to:



- Share – to copy, distribute and transmit this document
- Remix – to adapt this document



Under the following conditions:

- Attribution. You must give credit to CAWST as the original source of the document.
Please include our website: www.cawst.org

CAWST and its directors, employees, contractors and volunteers do not assume any responsibility for and make no warranty with respect to the results that may be obtained from the use of the information provided.

Chemical Parameters of Drinking Water

Fact Sheet: pH

Source

pH is a measure of the acidity or alkalinity of the water. The pH for drinking water generally lies between 6.5 and 8.0. Water at 25°C (80°F) with a pH less than 7.0 is considered acidic, while a pH greater than 7.0 is considered basic (alkaline). When the pH level is 7.0, the water is considered to have a neutral pH.

The pH of the water in a stream, river, lake or underground flow will vary depending on a number of conditions, such as the:

- Source of the water
- Type of soil, bedrock, and vegetation through which water travels
- Types of contaminants the water encounters in its path
- Amount of mixing and aeration of the water due to turbulence in its flow

Extreme values of pH can also result from accidental chemical spills, water treatment breakdowns, and insufficiently cured cement mortar pipe linings or cement mortar linings applied when the pH of the water is low (WHO, 2011).

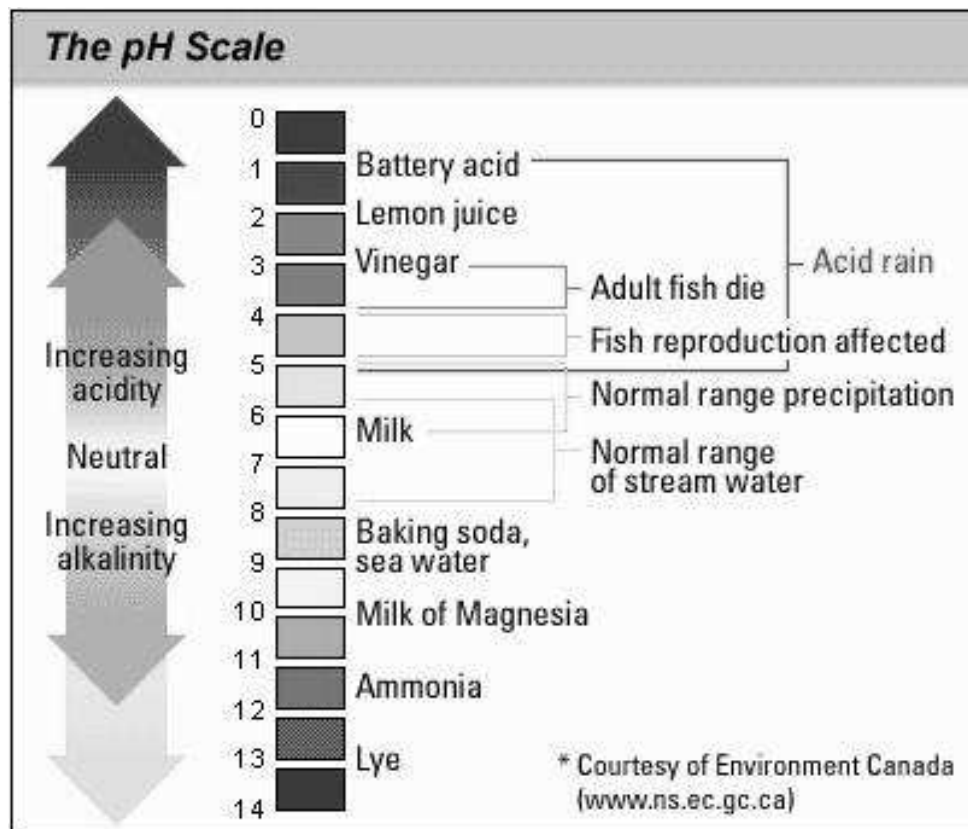

Chemical Parameters of Drinking Water

Fact Sheet: pH

Potential Health Effects

There are no direct health concerns for pH at levels normally found in drinking water.

World Health Organization Guidelines

There is no World Health Organization guideline value for pH since it is not a health concern at levels found in drinking water. However, the WHO notes that pH is an important operational water quality parameter (WHO, 2011).

No WHO Guideline for pH of Drinking Water

Water Quality Testing Methods

pH can be tested using a commercial laboratory or portable test kit. pH can be easily tested on-site using a digital pH meter or test strips. Some test strips only indicate whether the water is alkaline or acidic, while other test strips indicate the pH within the full range from 1 to 14. The most suitable range for pH test strips is between 4 to 9 because that is the pH of most natural waters).

Information about commercially available test kits are provided in CAWST's Drinking Water Quality Testing Product Sheets.

Household Water Treatment Options

The best way to deal with too high or low pH is to use a different source of drinking water.

pH is one of the most important parameters for the effectiveness of many water treatment technologies. For example, for effective disinfection with chlorine, the pH should be less than 8.

References

Environment Canada (2004). Canadian Water Quality Guidelines. Available at: www.ec.gc.ca/eau-water/default.asp?lang=En&n=FDF30C16-1

World Health Organization (2011). Guidelines for Drinking-Water Quality, Fourth Edition. WHO, Geneva, Switzerland. Available at: www.who.int/water_sanitation_health/dwq/secondaddendum20081119.pdf



Chemical Parameters of Drinking Water Fact Sheet: pH

CAWST (Centre for Affordable Water and Sanitation Technology)
Calgary, Alberta, Canada
Website: www.cawst.org Email: resources@caust.org
Wellness through Water.... Empowering People Globally
Last Update: October 2013

This document is open content. You are free to:



- Share – to copy, distribute and transmit this document
- Remix – to adapt this document



Under the following conditions:

- Attribution. You must give credit to CAWST as the original source of the document.
Please include our website: www.cawst.org

CAWST and its directors, employees, contractors and volunteers do not assume any responsibility for and make no warranty with respect to the results that may be obtained from the use of the information provided.

Chemical Parameters of Drinking Water Fact Sheet: Total Dissolved Solids

Sources

Total dissolved solids (TDS) is the term used to describe the inorganic salts (mainly sodium chloride, calcium, magnesium, and potassium) and small amounts of organic matter that are dissolved in water. Technically, anything that dissolves in water contributes to the TDS level.

There are areas of the world that have naturally high amounts of TDS in their drinking water. TDS in drinking water comes from natural sources, and to a lesser extent from sewage, urban runoff, and industrial wastewater. Brackish or saline aquifers can exist naturally or develop over time in coastal regions with sea water infiltration due to lowering aquifer depths.

- Fresh: <1,000 mg/L TDS
- Brackish: 1,000–5,000 mg/L TDS
- Highly Brackish: 5,000–15,000 mg/L TDS
- Saline: 15,000–30,000 mg/L TDS
- Sea Water: 30,000–40,000 mg/L TDS

(Water Quality Association, nd)

Fresh water with high or low levels of TDS is often called “hard” or “soft” water, respectively. Hard water received this name because it requires more soap to get a good lather and makes the water “hard” to work with. Soap is less effective with hard water due to its reaction with the magnesium and calcium, leading to high use of soap for laundry and bathing. As well, hard water (>500 mg/L) can leave a residue and cause scale to build up on household appliances (e.g., electric kettle, dishwasher), cooking pots, and water pipes.

Soft water is usually preferred for laundry, bathing and cooking.

Potential Health Effects

Although there are no direct health concerns of drinking water with high concentrations of TDS, the presence of dissolved solids in water may affect its taste. People generally prefer the taste of hard water due to the dissolved minerals, however high concentrations of TDS can cause a bitter or salty taste. According to the World Health Organization (2003), the acceptability of drinking water has been rated by a panel of tasters in relation to its TDS concentrations as follows:

- Excellent: <300 mg/L
- Good: 300-600 mg/L
- Fair: 600-900 mg/L
- Poor: 900-1,200 mg/L (e.g., brackish water)
- Unacceptable: >1,200 mg/L (e.g., saline water)

Chemical Parameters of Drinking Water

Fact Sheet: Total Dissolved Solids

Some people can taste salt in drinking water at levels around 500 mg/L, and it may cause them to not use it and choose another, possibly contaminated, water source instead. Water with extremely low TDS concentrations (e.g., rainwater) may also be unacceptable because of its flat taste.

World Health Organization Guidelines

The World Health Organization (WHO) does not have a suggested guideline for total dissolved solids since it occurs in drinking water at concentrations well below those at which health effects may occur. Most people will reject drinking water due to odour, taste, and colour at a level much lower than is required for harm. People usually do not like the taste of water that has more than 600 mg/L of TDS (WHO, 2011).

No WHO Guideline for Total Dissolved Solids in Drinking Water

Water Quality Testing Methods

Dissolved ions increase the electrical conductivity (EC) of water, which is easily measured with a digital meter, so testing for EC is often done instead of testing directly for TDS. EC in microsiemens per centimetre ($\mu\text{S}/\text{cm}$) usually ranges from 1 to 2 times the TDS in mg/L (UNICEF, 2008).

Testing for EC does not give specific information about the chemicals present in water, but it gives an estimation of the TDS. More specific testing must be done to discover which chemicals are present.

Household Water Treatment Options

There are some limited household options to remove total dissolved solids from drinking water. Filtration does not work since the chemicals and organic matter are dissolved in the water. Distillation technologies can help reduce TDS levels in drinking water; however they may not be practical or easy to use at the household level. Reverse osmosis systems are becoming popular in industrialized countries for removing TDS, however they are relatively expensive and require a power supply.

Chemical Parameters of Drinking Water Fact Sheet: Total Dissolved Solids

References

UNICEF (2008). UNICEF Handbook on Water Quality. UNICEF, New York, USA. Available at: www.unicef.org/wes/files/WQ_Handbook_final_signed_16_April_2008.pdf

Water Quality Association (n.d.). Water Classifications. Available at: www.pacificro.com/watercla.htm

World Health Organization (2003). Total Dissolved Solids in Drinking-Water: Background Document for Development of WHO Guidelines for Drinking-Water Quality. WHO, Geneva, Switzerland. Available at: www.who.int/water_sanitation_health/dwq/chemicals/tds.pdf

World Health Organization (2011). Guidelines for Drinking-Water Quality, Fourth Edition. WHO, Geneva, Switzerland. Available at: www.who.int/water_sanitation_health/dwq/secondaddendum20081119.pdf

CAWST (Centre for Affordable Water and Sanitation Technology)
Calgary, Alberta, Canada
Website: www.cawst.org Email: resources@caust.org
Wellness through Water.... Empowering People Globally
Last Update: October 2013

This document is open content. You are free to:



- Share – to copy, distribute and transmit this document
- Remix – to adapt this document



Under the following conditions:

- Attribution. You must give credit to CAWST as the original source of the document. Please include our website: www.cawst.org

CAWST and its directors, employees, contractors and volunteers do not assume any responsibility for and make no warranty with respect to the results that may be obtained from the use of the information provided.



Introduction to Drinking Water Quality Testing

Appendix 4: WHO Guidelines for Chemicals and Health Effects

Table of Contents

Appendix 4: WHO Guidelines for Chemicals and Health Effects	i
4.1 WHO Guidelines for Drinking Water Quality: Selected Chemicals.....	1
4.2 Potential Health Effects of Chemicals in Drinking Water	3



4.1 WHO Guidelines for Drinking Water Quality: Selected Chemicals

Chemical	Guideline Value
Aluminium	A health based value of 0.9 mg/L could be determined, but this value exceeds practical levels based on the coagulation process in drinking water treatment using aluminium based coagulants: 0.1 mg/L or less in large water treatment facilities and 0.2 mg/L or less in small facilities
Ammonia	Occurs in drinking water at concentrations well below those of health concern
Antimony	0.02 mg/L
Arsenic	0.01 mg/L (A,T)
Barium	0.7 mg/L
Boron	2.4 mg/L
Cadmium	0.003 mg/L
Chlorine	5 mg/L (C)
Chromium	0.05 mg/L (P)
Copper	2.0 mg/L
Cyanide	Occurs in drinking water at concentrations well below those of health concern, except in emergency situations following a spill to a water source
Fluoride	1.5 mg/L (volume of water consumed and intake from other sources should be considered when setting national standards)
Hardness	Not of health concern at levels found in drinking water ¹
Iron	Not of health concern at levels causing acceptability problems in drinking water ¹
Lead	0.01 mg/L (A,T)
Manganese	Not of health concern at levels causing acceptability problems in drinking water ¹
Mercury	0.006 mg/L (for inorganic mercury)
Nickel	0.07 mg/L
Nitrate	50 mg/L (short-term exposure)
Nitrite	3 mg/L (short-term exposure)
pH	Not of health concern at levels found in drinking water ²
Phosphate	Not listed in the WHO guidelines
Potassium	Occurs in drinking water at concentrations well below those of health concern
Silver	Available data inadequate to determine a health based guideline value
Sodium	Not of health concern at levels found in drinking water ¹
Total dissolved solids (TDS)	Not of health concern at levels found in drinking water ¹
Uranium	0.03 mg/L (P) (only chemical aspects of uranium are addressed, does not include radiological effects)
Zinc	Not of health concern at levels found in drinking water ¹

(Adapted from WHO, 2011)

¹ May affect acceptability of drinking water

² An important operational parameter for water treatment

A, provisional guideline value because calculated guideline value is below the achievable quantification level

C, concentrations of the substance at or below the health-based guideline value may affect the appearance, taste or odour of the water, leading to consumer complaints

D, provisional guideline value because disinfection is likely to result in the guideline value being exceeded

P, provisional guideline value because of uncertainties in the health database

T, provisional guideline value because calculated guideline value is below the level that can be achieved through practical treatment methods, source protection, etc.

4.2 Potential Health Effects of Chemicals in Drinking Water

The effect of the chemical on human health depends largely upon the type of contaminant, its concentration in drinking water, and the length and frequency of exposure. The person's age, physical health condition, and immunity can also have a large influence on the resulting health effect. A list of various chemicals, the health impacts they pose, and potential contamination sources are provided in the following table.

Potential Health Effects of Various Chemicals in Drinking Water

Chemical	Potential Health Effect from Drinking Water	Source
Aluminium	Little indication that ingested aluminium (through food or water) is acutely toxic. No health based guideline is proposed.	Naturally occurring; most abundant metal. Aluminium salts are widely used in water treatment as coagulants to reduce organic matter, colour, turbidity, and microorganism levels.
Ammonia	Ammonia in drinking water is not of immediate health concern. No health based guideline is proposed. However, ammonia can impact disinfection efficiency, cause nitrite to form in distribution systems, cause the failure of filters for removing manganese, and cause taste and odour problems.	Sewage, industrial processes, and agricultural activities. Ammonia in water is an indicator of possible bacterial, sewage, and animal waste pollution.
Antimony	Itchy, rough and broken skin. Eczema and dermatitis result from long-term and regular contact with antimony.	High concentrations may occur from mining operations and active volcanic areas.
Arsenic	Skin disease (e.g., melanosis and keratosis). May lead to lung, bladder, kidney, skin, liver, and prostate cancer. Also known to cause vascular diseases, neurological effects, and infant developmental defects.	Naturally occurring; also used commercially and industrially in the manufacture of transistors, lasers and semi-conductors. Some areas have relatively high concentrations of arsenic in groundwater.
Barium	No evidence that barium is carcinogenic or mutagenic.	Used in a variety of industrial applications; however barium in water comes mainly from natural sources.
Boron	Toxic to the male reproductive tract and may cause developmental toxicity.	Used in the manufacture of glass, soaps and detergents and as flame retardants. Found naturally in groundwater, but its presence in surface water is often a result of discharging treated sewage that contains detergents. Conventional water treatment does not significantly remove boron.
Cadmium	High doses can cause kidney damage.	Used in the steel industry, plastics, and in batteries. Released in wastewater, fertilizers, and local air pollution. Contamination in drinking water may also be caused by galvanized pipes, solders, and metal fittings. Food is the main source of exposure.
Chloride	No health based guideline is proposed. However, more than 250 mg/L of chloride in drinking water can cause a strong taste.	Chloride in drinking water comes from natural sources, sewage, industrial effluents, and from urban runoff containing de-icing salt. Main source of human exposure is the addition of salt to food.

Chemical	Potential Health Effect from Drinking Water	Source
Chlorine	Effects are not likely to occur at levels of chlorine that are normally found in the environment. High dose of chlorine irritates the skin, the eyes, and the respiratory system.	Produced in large amounts and widely used industrially and domestically as an important disinfectant and bleach.
Chromium	No significant health effects have been attributed to chromium due to lack of research. Continued exposure to chromium-6 could result in skin reactions and may be carcinogenic if ingested.	Most common forms that occur in natural waters are trivalent chromium (chromium-3) and hexavalent chromium (chromium-6). Chromium-3 is essential to the human diet and is found in many food types. Chromium-6 occurs naturally in the environment, and can also be produced by industrial processes.
Copper	Copper is both an essential nutrient and drinking water contaminant. Can affect the gastrointestinal tract, impact may be greater on sensitive populations such as the carriers of the gene for Wilson disease and other metabolic disorders.	Used to make pipes, valves, and fittings. Copper sulphate pentahydrate is sometimes added to surface water to control algae. Primary source in drinking water is the corrosion of copper plumbing. Food and water are the primary sources of copper exposure in developed countries.
Cyanide	Long-term consumption affects the thyroid and the nervous system.	Can be found in some foods, particularly in some developing countries, and occasionally found in drinking water from industrial contamination.
Fluoride	Low concentrations (0.5-1.0 mg/L) provide protection against dental caries, especially in children. Higher levels can cause mottling of teeth and dental fluorosis. Much higher levels can result in skeletal damage.	Naturally occurring; used widely in industry; used to produce phosphate fertilizers. In most circumstances food is the main source of intake. Some areas have relatively high concentrations of fluoride in groundwater.
Iron	Essential element for human nutrition. No health based guideline is proposed.	Naturally occurring; one of most abundant metals. Also found in drinking water from corrosion of steel and cast iron pipes.
Lead	Infants, children and pregnant women are most susceptible. Infants and children: Delays in physical or mental development; deficits in attention span and learning abilities. Adults: Kidney problems; high blood pressure.	Used in the production of lead-acid batteries, solders, and alloys. Lead in drinking water is usually from household plumbing systems that use lead in pipes, solders, and fittings.
Manganese	Essential element for human nutrition. Adverse effects can result from both deficiency and overexposure.	Naturally occurring; one of most abundant metals, usually found with iron. Used in manufacturing and in cleaning, bleaching, and disinfection products. Food is the main source of exposure.
Mercury	Causes neurological symptoms and kidney damage.	Used in the mining industry, production of chlorine, electrical appliances, and in dental fillings for cavities. Food is the main source of exposure.
Nickel	Higher chances of lung cancer, nose cancer, birth defects, allergic reactions, heart disorders.	Naturally occurring; used in the production of stainless steel and nickel alloys. Food is the main source of exposure. However, nickel in water can be significant in areas where there is heavy industrial pollution or relatively high concentrations in groundwater.

Chemical	Potential Health Effect from Drinking Water	Source
Nitrate and Nitrite	Main health concern is methaemoglobinaemia, or blue baby syndrome, that occurs in infants that are usually bottle fed. Symptoms include shortness of breath and their skin turning blue due to the lack of oxygen.	Naturally occurring as part of the nitrogen cycle. Nitrate is used in fertilizers and sodium nitrite is a food preservative. Concentration of nitrate in groundwater and surface water is caused by agricultural runoff; leaching from septic tanks, and sewage. Nitrite is from microbial activity and may be intermittent.
Phosphate	Essential element for human nutrition. No health based guideline is proposed.	Naturally occurring; used in fertilizers for agriculture and in toothpaste and detergents (e.g. soap). Addition of high levels of phosphate to the natural environment can have significant ecological consequences. For example, high levels can cause algae blooms in surface water.
Potassium	Essential element for human nutrition. No health based guideline is proposed. Increased exposure could result in health effects in people with kidney disease or who are taking medication that interferes with normal potassium functions in the body.	Naturally occurring; not commonly found in drinking water at levels that are a concern to human health. However, drinking water treated by water softeners using potassium chloride may significantly increase exposure and result in adverse health effects in susceptible individuals.
Silver	Available data not enough to determine a health based guideline value. Only a small percentage of silver is absorbed by the body.	Naturally occurring; occasionally found in groundwater and surface. Silver salts are sometimes used as household water treatment to reduce bacteria (i.e., ceramic filters).
Sodium	No health based guideline is proposed.	Sodium salts (e.g., sodium chloride) are found in virtually all food and drinking water. Food is the main source of exposure. Water softeners can add significantly to the sodium content in drinking water.
Total Dissolved Solids (TDS)	Although there are no direct health concerns, very low or high concentrations may cause an objectionable taste.	TDS in drinking water comes from natural sources, sewage, urban runoff, and industrial wastewater. Concentrations of TDS in water vary greatly in different geological regions.
Uranium	Little information is available on the chronic health effects of exposure to uranium in drinking water. Radiological effects are not considered in the drinking water guidelines.	Naturally occurring; used mainly as a fuel in nuclear power stations. Contamination is caused by leaching from natural deposits, release from mining operations, emissions from the nuclear industry, combustion of coal and other fuels, and use of phosphate fertilizers that contain uranium.
Zinc	Zinc is an essential element for human nutrition. No health based guideline is proposed.	Found in virtually all food and drinking water. Food is the main source of exposure.

(Adapted from WHO, 2011)





Introduction to Drinking Water Quality Testing

Appendix 5: Culture Media

Table of Contents

Appendix 5: Culture Media..... i

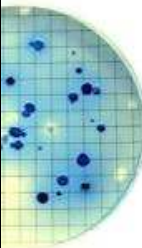

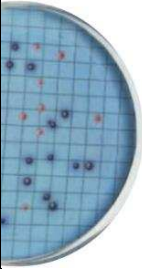
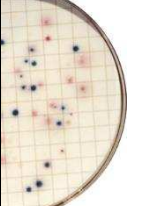
Photo	Culture Media	Type	Suitable for Indicators		Incubation Time and Temperature	Form / Container	Colony Counting
			TTC	<i>E. coli</i>			
	m-Lauryl Sulphate Broth (MLSB) Pink colour	Broth Nutri-Pad	X	X with confirmation test	~30°C for 4 hours, then 44 ± 0.5°C (for FC) for 14 hours 35.0 ± 0.5°C (for TC) for 18 hours	Powder (38.1 g or 500 g)	Both TTC and TC produce yellow colonies.
	m-Endo Magenta colour	Broth Agar Nutri-Pad		X	35.0 ± 0.5°C for 24 hours	Powder Dehydrated pads	TC produce blue colonies. <i>E. coli</i> produce dark red colonies with a green metallic sheen.
	m-FC Light blue colour	Broth Agar	X		44.5 ± 0.5°C	Powder	TTC produce blue to blue-grey colonies.
	m-TEC	Agar		X	35.0 ± 0.5°C for 2 hours, then 44.5 ± 0.5°C for 22- 24 hours	Powder	<i>E. coli</i> produce red-magenta colonies.
	m-ColiBlue24 Light blue colour	Broth Agar		X	35 ± 0.5°C for 22- 24 hours	Liquid (2 mL ampoules, 100 mL glass bottle) Prepared agar plates	<i>E. coli</i> produce blue colonies and TC produce red colonies.
	Coliscan MF Clear, sometimes very pale yellow colour	Broth Agar		X	Ambient to 37°C (ideally 34-37°C for 18-20 hours)	Frozen liquid (20 mL plastic bottles)	<i>E. coli</i> produce purple blue or dark blue colonies.

* TC = Total Coliforms, TTC = Thermotolerant Coliforms, *E. coli* = *Escherichia coli*

Introduction to Drinking Water Quality Testing

Appendix 6: Data Recording Forms

Table of Contents

Appendix 6: Data Recording Forms	i
6.1 Data Recording Form 1.....	1
6.2 Data Recording Form 2.....	3



6.1 Data Recording Form 1

Location: _____				Sample Taken By: _____							
Date of Sampling: _____				Sample Tested By: _____							
Sample Description	Sample ID #	Turbidity (NTU)	pH	Chlorine (mg/L)	Iron (mg/L)	Manganese (mg/L)	Arsenic (mg/L)	Nitrate (mg/L)	Fluoride (mg/L)	E. coli Plate Count (CFU/100 mL)	x Dilution Factor
											Total Count (CFU/100 mL)
Date of Report: _____											
Comments:											



6.2 Data Recording Form 2

Technician Name: _____

Sample Date: _____

Sample Location	Sample Description		<i>E. coli</i> Plate Count (CFU/100 mL)		X Dilution Factor		Comments and Observations		
					Total Count (CFU/100 mL)				
WHO Guidelines	pH -	Turbidity <1 NTU (large supplies) <5 NTU (small supplies)	Iron -	Manganese -	Arsenic 0.01 mg/L	Fluoride 1.5 mg/L	Chlorine 5 mg/L	Nitrate 50 mg/L	
Country Standards	pH	Turbidity NTU	Iron	Manganese	Arsenic	Fluoride	Chlorine	Nitrate	
Test Results									

Conclusions and Recommendations:



Introduction to Drinking Water Quality Testing

Appendix 7: Water Quality Testing Report

Table of Contents

Appendix 7: Water Quality Testing Report	i
7.1 Introduction	1
7.2 Example Report	2



7.1 Introduction

The report should be written by a qualified technician or manager with input and collaboration from field workers to help interpret the results and make appropriate recommendations.

The following is an example report for water quality monitoring of a small water supply and treatment project. In the example, all new water supplies (including drilled wells and hand dug wells) are tested in the beginning for chemical, physical, and microbiological parameters, and then every three months for physical and microbiological parameters, and every six months for chemical parameters.

In this example, random sampling was not necessary. In the case where a large number of water points need to be tested (such as a biosand filter project or a large geographical area), then the sampling method chosen should be explained in the “Methodology” section of the report.

7.2 Example Report

Quarterly Water Quality Report for October to December 2012

January 2013

Prepared by: A. Smith, Monitoring Officer, NGO Good Water Quality for All

1. Introduction

Water quality reports are produced every three months as part of the NGO's monitoring program. This is the fourth and final report for 2012 covering all project areas (Villages A, B, C and D) and all water supply and treatment systems (e.g., drilled wells, hand dug wells, biosand filters).

2. Objectives

Drinking water quality testing was undertaken within the NGO's project areas to:

1. Assess the quality of newly constructed water supply and treatment systems at the time of start-up (commissioning).
2. Monitor the ongoing quality of existing water supply and treatment systems. Though this report does include biosand filter water quality, it does not include analysis of the effectiveness of the biosand filters in the program. Refer to the report entitled "Biosand Filter Water Quality Testing Report – December 2012" which analyzed the effectiveness of biosand filters in Village D.

3. Testing Parameters

Monitoring microbiological quality is the first priority according to the country national standards and WHO Drinking Water Quality Guidelines (i.e., *E. coli*). Up to 10 CFU of *E. coli*/100 mL was used as the acceptable limit for drinking water. Other important priorities were the aesthetic quality of water (to ensure user acceptability) and contamination with chemicals of known health risk. Chemicals of concern in our project area include fluoride and arsenic. Aesthetic parameters include iron and manganese. The pH and turbidity of treated water were also tested in relation to household water treatment using the biosand filter and chlorination.

All new water supplies (including drilled wells and hand dug wells) were tested in the beginning for chemical, physical and microbiological parameters, and then every three months for physical and microbiological parameters, and every six months for chemical parameters.

4. Testing Methodology

Samples were collected in the field by trained field workers (see data collection sheets in Appendix 1) using sterilized sample bottles and placed in a cool box for transport to the project office. All testing was started within six hours of sample collection and done by a trained technician in a dedicated water quality testing room and clean environment.

Parameter	Test Method	Details
<i>E. coli</i>	Membrane filtration with Coliscan-MF culture media	See testing protocol in Appendix 2. Duplicate samples were tested. 1 field blank per batch of 20 samples.
pH	Test strips	Product: EMD test strips (ref.9588-3) with a range of pH 5 to pH 10.
Turbidity	Turbidity tube	Product: Palintest
Fluoride	Colour comparator	Product: Palintest colour disc and reagent (range 0 to 1.5 mg/L). Dilutions were made for concentrations beyond the testing range using boiled rainwater as the diluent.
Arsenic	Digital Arsenator	Range 2 to 100 ppb.
Iron	Test strips	Product: ITS Inc. Sensafe Iron Check (ref. 480125). Range 0 to 5 mg/L. Sensitivities: 0, 0.02, 0.05, 0.1, 0.2, 0.3, 0.5, 0.75, 1.0, 2.0, 5.0.
Manganese	Test strips	Product: ITS Inc. Sensafe Manganese Check (ref. 481020). Range 0 to 2 mg/L. Sensitivities: <0.02, 0.05, 0.1, 0.2, 0.5, 1.0, 2.0.

5. Results

The results were transcribed from data recording forms and summarized in the following table. The water quality information is grouped by source and village. For trend analysis purposes, the data from the past quarters have been included in the tables. All new data from October to December 2012 is marked in *italic*. Parameters exceeding the national drinking water quality standards are in **bold**.

Sample ID	Date (d-m-y)	pH	Turbidity (NTU)	Fluoride (ppm)	Arsenic (ppb)	Iron (ppm)	Manganese (ppm)	<i>E. coli</i> (CFU/100 mL)	Observations
Samples from Borehole (Market-BHA)									
<i>Location: Village A – Depth 52 m – India Mark II hand pump (Date of Commissioning: 12 Jan 2012)</i>									
BHA-1	12-01-12	8	10	0	0	0.3	0.2	15	Newly commissioned. Slab and pump are clean.
BHA-2	15-04-12	ND	<5	ND	ND	ND	ND	5	Slight metallic taste
BHA-3	10-07-12	7.9	<5	0	0	0.4	0.3	0	Metallic taste. Complaints from users
BHA-4	12-10-12	ND	<5	ND	ND	ND	ND	10	Slight colour (orange)
BHA-5	14-12-12	8	10	0	0	0.4	0.2	30	Cracks on slab around pump
Samples from Borehole (School-BHB)									
<i>Location: Village B - Depth 45m – India Mark II hand pump (Date of Commissioning: 13 Dec 2012)</i>									
BHB-1	14-12-12	7.2	<5	20	0	0.2	0	0	Water smells of chlorine
Samples from Hand Dug Well (HDC)									
<i>Location: Village C - Depth 8 m – Open well (Date of Commissioning: 6 Jul 2012)</i>									
HDC-1	10-07-12	7.5	10	0	0	0.1	0	150	
HDC-2	12-10-12	ND	40	ND	ND	ND	ND	260	Water looks slightly cloudy
HDC-3	14-12-12	4.5	50	0	0	0.1	0	500	Brownish colour water
Samples from Biosand Filter Outlet (Ref:BSD1)									
<i>Location: Village D (Installation Date: 10 Jan 2012)</i>									
BSD1-1	12-01-12	8	10	0	0	0.0	0	14	Water looks slightly cloudy
BSD1-2	15-04-12	ND	5	ND	ND	ND	ND	10	
BSD1-3	10-07-12	7.5	<5	0	100	0	0.01	0	Borehole water used in dry season
BSD1-4	12-10-12	ND	<5	ND	ND	ND	ND	10	
BSD1-5	14-12-12	8	5	0	0	0.0	0	3	

ND = Parameter was not tested.

6. Interpretation and Recommendations

Summary

- The microbiological quality of most water supply and treatment systems tested were within acceptable range (0 to 14 *E. coli* CFU/100 mL), except the hand dug well in Village C (ref: HDC) has increased levels of fecal contamination (500 CFU/100 mL in the latest test) and recently the Market Borehole in Village A.
- At the newly commissioned borehole at the school in Village B, the fluoride level was 20 ppm and exceeded the national standard of 1.5 ppm.
- In a biosand filter (BSD1) in Village D in July 2012, the arsenic concentration was 100 ppb and exceeded the national standard of 10 ppb.

Village A

The turbidity for the market borehole (BHA) is high (should be <5 NTU). The variation in the rainy season shows possible infiltration of surface water or poor development of the borehole. Either of these situations could lead to microbiological contamination. We recommend the following actions:

- More water quality testing.
- Checking the quality of the slab around the hand pump.
- Checking drilling records to make sure that the borehole was constructed properly.
- Rehabilitating the borehole, if necessary.

A high iron concentration still seems to be a problem. We recommend the following actions:

- More water quality testing.
- Surveying the users to determine if the iron is objectionable and causing people to use less safe water sources.
- Asking the users to treat their drinking water by settling and filtration.
- Having community health promoters explain to the users that iron is a bother, but it is not harmful to their health.

Village B

This is a new borehole and these are the first water quality test results. The fluoride level was more than 10 times over the national standard. We recommend doing further fluoride tests to confirm the concentration as soon as possible.

Village C

The hand dug well (ref: HDC) showed significant and increasing levels of fecal contamination (500 CFU/100 mL) since the commissioning of the well in July 2012. This could be due to surface water infiltration and/or poor maintenance. We recommend the following actions:

- Checking the well lining.
- Conducting a sanitary inspection of the area.
- Asking the users to treat the water to make it safe to drink.

Village D

The July 2012 water quality testing showed 100 ppb of arsenic in one of the biosand filters. Further investigations in August 2012 confirmed that the biosand filter users in the area were using borehole water in the dry season (i.e., a borehole which was contaminated with arsenic) because the hand dug well dried up. We recommend the following actions:

- Adapting the biosand filters in the area to reduce arsenic (by adding iron nails to the diffuser box) or using another drinking water source in the dry season.

Further arsenic testing to confirm the level of arsenic contamination.

Introduction to Drinking Water Quality Testing

Appendix 8: International Travel with Test Equipment and Materials

Table of Contents

Appendix 8: International Travel with Test Equipment and Materials.....	i
8.1 Purchasing.....	1
8.2 Before Travel.....	1
8.3 Air Travel.....	1
8.4 At Security and Custom Controls.....	2
8.5 Upon Arrival.....	2



8.1 Purchasing

- Purchasing equipment is much cheaper in the United States and United Kingdom, but you must pay shipping, handling fees, taxes, and duty if you are leaving the equipment in country.
- Ordering in country may have a delay and will be at least 50% more expensive, but you avoid any travel issues. Sometimes it is worth paying more and waiting.
- See Country Fact Sheets in Appendix 9 for specific country information on where to purchase equipment and products locally.

8.2 Before Travel

- Check contents of the portable test kit before travel and make an inventory list.
- If batteries are removed from the portable test kit, protect them by using bubble wrap or other protection.
- Check if travel or baggage insurance applies to transporting portable test kits.
- Lock your bags when traveling by airplane, bus or other public transit. Buy a “TSA approved lock” for your checked baggage if traveling by air to the United States, otherwise the lock will be destroyed in the security check.

8.3 Air Travel

- Keep two copies of all your documents (e.g., invoices, inventory list, CAWST letter): one for your carry-on bags and one for your checked baggage.
- Try bringing portable test kits as a carry-on bag. Any liquids (e.g., calibration fluids, be sure to check in the lid of the kit), chemical reagents, sharp objects, as well as the incubator battery, must be taken out and put in your checked baggage. Tape over the battery terminals to protect them. DelAgua kits have integrated batteries so it must go in your checked baggage. Sometimes airports will insist on portable test kits being put into checked baggage (depends on size).
- Use insulated bags and ice packs when transporting frozen culture media or media that requires refrigeration (e.g., Coliscan, m-ColiBlue24) and put them in your checked baggage.
- Travelling with methanol is illegal (even in your checked baggage). It is considered to be a hazardous and flammable substance.
- Do not lock portable test kits if you are taking them as carry-on bags since you will be asked to open the kit at security. If you choose to lock the kit, have the key handy and be prepared to open the kit.

8.4 At Security and Custom Controls

- If borrowing a portable test kit from CAWST, carry a letter from CAWST stating that the portable test kit belongs to CAWST and will be returned.
- If leaving a portable test kit in country, carry the original invoice when importing, declare the items, and pay the duty at customs.
- Check if the local organization has tax exemption status and you can avoid paying duty. You will need the necessary documentation.
- Customs documents may be required for transport into some countries (e.g., Ethiopia). The documents may have to be updated each trip; it depends on the destination.
- See if appropriate translations are needed for letters or other documentation.
- Customs may record the entry in your passport and look for the portable test kit items on your return trip.
- Carry Material Safety Data Sheets (MSDS) for any chemicals or culture media, but only show them if they are required since the symbols and warnings can be alarming. You need to contact the manufacturer to supply the MSDS for their products.
- Consider putting chemical reagents in sealable plastic bags (e.g., Ziploc) rather than using the original boxes. Some countries mistake the reagent for the chemical it is testing for. If it is a controlled substance, then they may confiscate the reagents. For example, this has happened in Uganda where the reagent for testing fluoride was confiscated because the word “fluoride” was on the box.

8.5 Upon Arrival

- Refrigerate culture media at your hotel (i.e., in room or hotels will often allow you to use the kitchen fridge). Consider using alternate culture media if refrigeration is not locally available.
- Check contents of the portable test kit after travel using your inventory list.
- Check integrity of any batteries (e.g., holds charge, no leaking).

Introduction to Drinking Water Quality Testing

Appendix 9: Country Fact Sheets

Drinking Water Quality Testing Country Fact Sheet: Afghanistan

Country Drinking Water Quality Standards

Drinking Water Quality Parameter	National Standard
Microbiological (e.g., <i>E. coli</i>)	0 CFU/100 mL
Turbidity	5 NTU
pH	6.5 – 8.5
TDS (Total Dissolved Solid)	1,000 mg/L-2,000 mg/L
Total Hardness	500 mg/L
Nitrate	50 mg/L
Nitrite	3 mg/L
Barium	0.7 mg/L
Boron	2.4 mg/L
Arsenic	0.05 mg/L
Fluoride	1.5 mg/L
Lead	0.01 mg/L
Cyanide	0.05 mg/L
Nickel	0.07 mg/L
Nitrate as Nitrogen	11 mg/L
Zinc	3 mg/L
Selenium	3 mg/L
Chloride	250 mg/L
Sulfate	250 mg/L

Laboratories

Private Companies

- **Venco Intiaz Construction Company (VICC)**

Street 15, Lane 2, House 55, Wazir Akbar Khan, Kabul, Afghanistan
 Tel: Main Office (0093) 020 210 4489, (0093) 799 218 272 / 700225 757
 Website: www.viccbiz.cm

Drinking Water Quality Testing Country Fact Sheet: Afghanistan

- **Zurmat Material Testing Laboratories**

Kabul Main Office; House # 01, Street # 1, District # 06, Kart-e-Seh, Opposite Habibya High School, Kabul, Afghanistan
Cell: +93 (0) 796 001005
Website: www.zurmat-mtl.com

- **Greentec Engineering and Consulting Company**

Street # 8, Opposite of New Oxford High School, Kart-e-Seh, Kabul Afghanistan
Cell: +93 (0) 779 523 567 / 786 330 026
Email: lab@greentec.af
Website: www.greentec.af

Other Organizations

- **DACAAR Water Quality Lab**

DACAAR Kabul Office
Qalayee Fatullah, Road No. 12, Street No.3, House No. 403,
Paykob-e-Naswar, Kabul, Afghanistan
Contact DACAAR Reception: +93 (0) 202230753 / 202230752,
Contact Person DACAAR WET Centre: +93 (0) 797369025, Email: azeem@dacaar.org

- **Ministry of Rural Rehabilitation and Development (MRRD) Water Quality Laboratory**

Tashkilat Street, Nilabagh, Darulaman Road
Kabul, Afghanistan
Contact Person: Eng. Ali Mohammad, Email: ali.mohammad@mrrd.gov.af ,
Tel: +93 (0) 772378260

- **Minsitry of Public Health (MoPH) Water Quality Laboratory**

Near US Embassy, District 10, Charahi Sehat Aama
Tel: +93 (0) 202301377 / 202301351 / 799311934
Contact Person: Eng. Mohammad Ali Akbari, Head of WASH Department of MoPH
Tel:+93 (0)706713098 - 783410917
Email: Ali_akbari786@yahoo.com
Website: www.moph.gov.af

- **MoPH Water Quality Lab at Mazar-e-Sharif** (no contact information available)

- **MoPH Water Quality Lab at Kandahar** (no contact information available)

- **Afghanistan Water Supply & Sewerage Corporation (AUWSSC)**

Kabul, Afghanistan
Contact: M.Latif Muzafarkhil, Head of Strategic Business Unit (SBU) Kabul
Cell: +93(0) 799 816 213
Email: mohammadlatif7@gmail.com
Email: m.latif@auwssc.gov.af



Drinking Water Quality Testing Country Fact Sheet: Afghanistan

Local Organizations Doing Water Quality Testing

- **DACAAR WET Centre**

Provides microbiological, physical and chemical water quality analysis using Potatest Portable Incubator Kits, Photometers Palintest 8000 Wagtech, Interface Photometer Palintest 7000 Wagtech, Spectrophotometer Spectro Flex 6600, Digital Arsenator Wagtech, Digital pH/Conductivity Meter WTW 340i, Digital Turbidimeter; WTW 340 IR, and Digital Dissolved Oxygen Meter WTW multi 3410.

Paikob-e-Naswar, Wazirabad, Kabul Afghanistan
Telephone: +93 (0) 20 223 07 52 / 223 07 53, +93 (0) 797 36 90 25,
Email: dacaar@dacaar.org, azeem@dacaar.org

- **Swedish Committe for Afghanistan (SCA)**

Using chemical testing equipment (HACH) and Digital Arsenator (Wagtech)

Jalalabad Main Road Paktia Kot, left side, 8 kms from Charrahi Abdul Haqq,
PO Box 5017
Tel: +93 (0) 700703653 / 0202320152, / 752023567
Fax: 00930202320156
Email: andreas.stefansson@sca.org.af, info@sca.org.af
Website: www.swedishcommittee.org

- **ZOA Afghanistan (ZOA)**

Using Photometer 7100 for chemical testing, Delagua test kit, and EC meter

Hs. 266, St. 2 (next to Ahmad Jam Mosque), District 3, Karte Char,
PO Box 1515
Tel: +93 (0) 793570388 / 700239825 / 700213949
Email: pga-co@zoa-afg.org, offioffice-mgtcentral@zoa-afg.org
Website: www.zoa-international.com

- **Japan Emergency NGO (JEN)**

Using Digital Arsenator, Potatest Kit, and EC meter
Sayed Inayatullah "Hashimi" Project Manger, JEN/Afghanistan
Phone: +93 (0) 700050464 / 77233533
Email: hashimi@jen-npo.org

- **Action Contre La Faim (ACF)**

Using kits for microbiological and physical tests

Herati Mosque Street (near to the Etisalat building), Shahr-i-Naw
Tel: +93 (0) 799566128/ 008821623127491
Email: hom@af.missions-acf.org, kabul@af.missions-acf.org
Website: www.actioncontrelafaim.org



Drinking Water Quality Testing Country Fact Sheet: Afghanistan

- **Welthungerhilfe/ German Agro Action (GAA)**

Using kit for physical tests and Delauga test kit

M. Rahim Yaqin, Deputy Project Manager, Water & Sanitation Project, WHH, Sheberghan

Tel: +93 (0) 700 71 53 25

Email: mohammad.rahim@welthungerhilfe.de,

- **Aga Khan Foundation Afghanistan (AKF)**

Using Delagua test kit, kits for physical tests, Arsenator, and Photometer 7100

Hs. 41, St. 2 Qala-i-Fatullah

PO Box 5753

Tel: +93 (0) 791981910 / 700299174 / 798589868

Fax: 0202301189

Email: muslim.khurasan@akdn.org, info.info@akdn.org

Web: www.akdn.org/akf

- **Solidarites International**

Using Potatest kit

Hs. 41, St. 12 (near Pai Kuba Naswar), Qala-i-Fatullah

Tel: +93 (0) 799303633 / 771939523

Email: afg.cdm@solidarites-afghanistan.org, afg.adm.coo@solidarites-afghanistan.org,

Website: www.solidarites.org

- **Relief International (RI)**

Using microbiological and physical test kits

Hs.23, Old Taimani, Golayee Nal, District 10

Tel: +93 (0) 777721571

Email: Inge.detlefsen@ri.org

Website: www.ri.org

- **Agence d'Aide à la Coopération Technique Et au Développement (ACTED)**

Using physical and microbiological test kits

Chidambaram. CT, Head of Programs ACTED, Kabul

Email: ct.chidambaram@acted.org,

Website: www.acted.org

Sayed Shir Hussain Honaryar, Appraisal Monitoring Evaluation Unit (AMEU) Manager

Tel: +93 (0)799343279

Email: sayed.hussain@acted.org

Dost Mohammad Rokai, Faizabad Base Manager

Tel: +93 (0) 700 70 14 59 / 788 43 01 95/ 793 61 60 61

Email: rokai_2013@Yahoo.com



Drinking Water Quality Testing Country Fact Sheet: Afghanistan

- **Tearfund (TF)**

Using physical and microbiological test kits

Hs. 508, St. 9 Taimani, kabul

PO Box 383

Tel: +93 (0) 789026011 / 787841813 / 799337231

Email: afghan-pd@tearfund.org, afghan-dpd@tearfund.org

Web: www.tearfund.org

Local Organizations Providing Training for Water Quality Testing

- **DACAAR WET Centre**

Paikob-e-Naswar, Wazirabad, Kabul Afghanistan

Telephone: +93 (0) 20 223 07 52 / 223 07 53, +93 (0) 797 36 90 25,

Email: dacaar@dacaar.org, azeem@dacaar.org

Local Suppliers

Hardware Equipment

- No hardware equipment is available in the country, must be imported
- **Yahya Hakimi & Brother Co. Ltd**

1st floor, Ariana Plaza, Karta-e-Ariana, Sallang Watt Street

Kabul, Afghanistan

Email: m_yahya007@hotmail.com

Email: yhbl.ltd@gmail.com

Tel: +93 799313566 / +93 777313566

Supplies all types of hardware (e.g., test kits)

Consumable Items

- No consumable items are available in the country, must be imported

- Yahya Hakimi & Brother Co.ltd

1st floor, Ariana Plaza, Karta-e-Ariana, Sallang Watt Street

Kabul, Afghanistan

Email: m_yahya007@hotmail.com

Email: yhbl.ltd@gmail.com

Tel: +93 799313566 / +93 777313566

Supplies all types of consumables (e.g., methanol, reagents, distilled water, sterile pipettes, sampling bottles/bags, Petri dishes, filter paper, filter pads, media)

Membrane Filtration Culture Media Used in the Country

- Membrane Lauryl Sulphate Broth (MLSB) is the most common culture media used and available in Afghanistan.



Drinking Water Quality Testing Country Fact Sheet: Afghanistan

Tips for Working in the Country

- Importing equipment and consumable items can take up to three months due to getting tax exception clearance documents from different government departments (Ministry of Economy, Ministry of Rural Rehabilitation and Development, Ministry of Public Health, Custom Department). The government charges 20% tax on all imported items.
- Even if the government tax is paid, it will still take more than a month to get clearance for imported items from the Customs Department.
- Need to consider shelf life (expiration date) of the products due to the long time it takes to get into the country.
- Costs associated with importing equipment is much less than buying in-country.
- Tips for importing equipment

GFL: produces water stills

PO Box 11 52, 30927, Burgwedel, Germany

Tel: +49 (0) 51399958-0

Fax: +49 (0) 5139995821

Email: info@GFL.de

Website: www.GFL.de

WTW: produces water quality laboratory equipment.

Tel: +49 (0) 881183-0, +49 (0) 881183-100

Fax: +49 (0) 881183-420

Email: Info@WTW.com

Website: www.TWT.com

Wagtech International Ltd: produces water quality laboratory equipment

Wagtech Cort, Station Road

RG19 4HZ, United Kingdom

Tel: +44 (0) 1635872929

Fax: +44 (0) 1635862898

Email: export@wagtech.co.uk

Website: www.wagtech.co.uk

Palintest: produces water quality laboratory equipment.

Tel: +44 (0) 1914910808 ext.276

Fax: +44 (0) 1914825372

Email: Ben.lind@palintest.com

Website: www.palintest.com



Drinking Water Quality Testing Country Fact Sheet: Afghanistan

CAWST (Centre for Affordable Water and Sanitation Technology)
Calgary, Alberta, Canada
Website: www.cawst.org Email: resources@caust.org
Wellness through Water.... Empowering People Globally
Last Update: October 2013

This document is open content. You are free to:



- Share – to copy, distribute and transmit this document
- Remix – to adapt this document



Under the following conditions:

- Attribution. You must give credit to CAWST as the original source of the document.
Please include our website: www.cawst.org

CAWST does not assume any responsibility for and makes no warranty with respect to the quality of the laboratory services, equipment or consummable products listed in this document.

Drinking Water Quality Testing Country Fact Sheet: Ethiopia

Country Drinking Water Quality Standards

Drinking Water Quality Parameter	National Standard
Microbiological (e.g., <i>E. coli</i>)	0 CFU/100 mL
Turbidity	5 NTU
Nitrate	50 mg/L
Arsenic	0.01 mg/L
Fluoride	1.5 mg/L
Iron	0.3 mg/L

Laboratories

Licensed

- **Ministry of Water and Energy**

Haile G/Silassie Avenue
P.O.Box 5744 and 5744
Addis Ababa, Ethiopia
Tel: +251-1-6611111
Email: info@mowr.gov.et

- **Regional Health Bureaus**

According to the Federal Ministry of Health, Department of Hygiene and Environmental Health, the following regional health laboratories are able to test the microbiological quality of water:

- Tigray Health Research Center at Mekelle (Tigray Regional State)
- Public Health Laboratory of Dessie town (Amhara Regional State)
- Amhara Health Research Laboratory at Bahir Dar (Amhara Regional State)
- Public Health Regional Laboratory of Awassa (SNNPR)
- Public Health Regional Laboratory of Arba Minch town(SNNPR)
- Public Health Regional Laboratory of Mizan Teferi town (SNNPR)
- Public Health Regional Laboratory of Jinka town (SNNPR)
- Public Health Regional Laboratory of Jimma town (Oromiya Regional State)
- Public Health Regional Laboratory of Adama town (Oromiya Regional State)
- Public Health Regional Laboratory of Nekemte town (Oromiya Regional State)
- Public Health Regional Laboratory of Harar town (Oromiya Regional State)

Drinking Water Quality Testing Country Fact Sheet: Ethiopia

- **Addis Ababa Water and Sewerage Authority**
PO Box 1505
Addis Ababa, Ethiopia
Website: www.aawsa.gov.et
- **Quality and Standard Authority of Ethiopia**
Ethiopian Standards Agency
PO Box 2310
Addis Ababa, Ethiopia
Tel: +251 11 6 46 01 11
Fax: +251 11 6 46 08 80
Website: www.ethiostandards.org
Email: info@ethiostandards.org
- **Water Work Design and Supervision Enterprise Laboratory Service Sub Process**
PO Box 2561
Addis Ababa, Ethiopia
Phone: (+251) 0116614501/116-185516
Fax: (+251) 0116615371/610898
Website: www.wwdse.com.et
Email: w.w.d.s.e@telecom.net.et
- **Awash Melkasa Aluminum Sulfate and Sulfuric Acid Share Company**
Awash Melkasa Aluminium Sulphate
PO Box 15757
Tel: 554571/0221114703/0221113809
Cell: 11207313
Fax: 0221114702
Email: amassaf@ethionet.et
- **Environmental Authority of Ethiopia** (no address or contact information)
- **Ethiopian Agricultural Research Organization** (no address or contact information)
- **Institution of Geological Survey** (no address or contact information)

Non-licensed

- None are known



Drinking Water Quality Testing Country Fact Sheet: Ethiopia

Local Organizations Doing Water Quality Testing

- **Ethiopian Kale Heywet Church Development Programme (EKHCDP), Addis Ababa**

Provides microbiological, physical and chemical water quality analysis using Wagtech and Delagua test kits and equipment.

PO Box 5829

Addis Ababa, Ethiopia

Tel: 0115526201

Fax: 0115512763

Website: www.ekhc.org

Email: saraelon@yahoo.com

Contact: Addise Amado Program Manager for Water and Sanitation

Local Organizations Providing Training for Water Quality Testing

- **Ethiopian Kale Heywet Church Development Programme (EKHCDP), Addis Ababa**

PO Box 5829

Addis Ababa, Ethiopia

Tel: 0115526201

Fax: 0115512763

Website: www.ekhc.org

Email: saraelon@yahoo.com

Contact: Addise Amado Program Manager for Water and Sanitation

Type of training provided: Introduction to Drinking Water Quality Testing workshops

Audience: Government staff, nongovernmental organizations (NGOs), community based organizations (CBOs), individuals working in the water and sanitation sectors

- **Wagtech Ethiopia P.L.C**

PO Box 14585

Addis Ababa, Ethiopia

Tel: 0116633280

Fax: 0116633281

Email: info@wagtechethiopia.com

Type of training provided: Physical, chemical, and microbiological water quality testing

Audience: Anyone who purchases equipment or kits from Wagtech



Drinking Water Quality Testing Country Fact Sheet: Ethiopia

Local Suppliers

Hardware Equipment

- **Wagtech Ethiopia PLC**

P.O.Box 14585
Addis Ababa, Ethiopia
Email: info@wagtechethiopia.com
Tel: 0116633280
Fax: 0116633281

Type of Hardware

Potakit
Potalab
Arsenator for arsenic testing

- **Hach Distributor**

Addis Ababa, Ethiopia

Type of Hardware

Incubator
Filtration apparatus
Glassware

Consumable Items

- **Afro German Chemicals EST.PLC**

Tel: (+251-011)1550200
Cell : (+251-091)1470276
Fax: (+251-011)1551057
Email: yitbarek.tsegaye@yahoo.com

Type of Consumables

Methanol

- **BIO.MED**

Tel: (+251-011)-4-674417/ 698886
Cell: (+251-091)1233044
Email: bio-med@ethionet.et

Type of Consumables

Sampling bottles
Methanol
Ethanol
Distilled water

- **BORUFIS**

Tel: (+251-011)4-6603-27
Cell: (+251-0911)-514479/465019
Fax: (+251- 011)4-669995
Email: bemsplc@ethionet.et

Type of Consumables

Sampling bottles
Methanol
Ethanol
Distilled water

- **General Chemicals & Trading**

Tel: (+251-011)5510287/88,
Cell: (+251-091)1201107
Fax: (+251-011)5514979
Email: gct@ethionet.et

Type of Consumables

Methanol
Ethanol
Distilled water



Drinking Water Quality Testing Country Fact Sheet: Ethiopia

- **LOPHA Pharmaceuticals**
Tel: (+251-111) 4655897/4668616
Cell: (+251-911-253600)
Fax: +251-114668615
Website:
www.lophapharmaceuticals.com
Type of Consumables
Methanol
Ethanol
Distilled water
Sample bottle
- **Hach Distributor**
Addis Ababa, Ethiopia
Type of Consumables
m-ColiBlue24 culture media
Dilution water (buffered)
Filter paper
Petri dishes and pads
- **WISE TEAM PLC**
Tel: 251-111-564514
Cell: 251-91-1607340
Email: wiseteam@ethionet.et
Type of Consumables
Sampling bottles
Ethanol
Methanol
- **Wagtech Ethiopia**
Wagtec Ethiopia PLC
PO Box 14585
Addis Ababa, Ethiopia
Email: info@wagtechethiopia.com
Tel: 0116633280
Fax: 0116633281
Type of Consumables
Reagents
Pipettes
MLSB culture media

Membrane Filtration Culture Media Used in the Country

- Membrane Lauryl Sulphate Broth (MLSB)
- m-ColiBlue24

Tips for Working in the Country

- Importing equipment and supplies is expensive, customs and duty are high (may have tax exemption if a not for profit organization).
- Wagtech has a supplier in country, but be prepared for substantially higher costs than buying direct (up to 3 times the cost).
- Be aware of the electrical outlet configuration for imported equipment. If it is a South African plug, it is difficult to get the proper adapter in Ethiopia.

Drinking Water Quality Testing Country Fact Sheet: Ethiopia

CAWST (Centre for Affordable Water and Sanitation Technology)
Calgary, Alberta, Canada
Website: www.cawst.org Email: resources@caust.org
Wellness through Water.... Empowering People Globally
Last Update: October 2013

This document is open content. You are free to:



- Share – to copy, distribute and transmit this document
- Remix – to adapt this document



Under the following conditions:

- Attribution. You must give credit to CAWST as the original source of the document.
Please include our website: www.cawst.org

CAWST does not assume any responsibility for and makes no warranty with respect to the quality of the laboratory services, equipment or consummable products listed in this document.



Drinking Water Quality Testing Country Fact Sheet: Haiti

Country Drinking Water Quality Standards

Drinking Water Quality Parameter	National Standard
Microbiological (e.g., <i>E. coli</i>)	0 CFU/100 mL
Turbidity	1 NTU for drinking water
Turbidity	5 NTU for prospection ¹
Nitrate	50 mg/L (WHO guideline value)
Arsenic	0.01 mg/L (WHO guideline value)
Fluoride	1.5 mg/L (WHO guideline value)
Other	WHO guideline values

¹ Prospection: When people start exploiting a new water source (e.g., wells), the turbidity is relatively high and decreases with time. This is the highest level of turbidity admissible for new water sources.

Laboratories

Licensed

- Laboratoire Vétérinaire et de Contrôle de Qualité des Aliments de Tamarinier (LVCQAT)**
 Rte Nle #1, km 15, Bon Repos
 Tel: (+509) 22 28 63 46
 Email: famv@ueh.edu.ht
- Centre Technique d'Exploitation de la Région Métropolitaine Port-au-Prince (CTE-RMPP, DINEPA)**
 Blvd Toussaint Louverture, Bloc 3 Mains, Port-au-Prince, Haiti
 Tel: +50936369196 / +50936404126
- Faculte d'Agronomie et de Medecine Veterinaire (FAMV)**
 Route Nationale numéro 1, Damien, Port-au-Prince, Haiti
 Tel: (+509) 22 22 47 81 / (+509) 22 22 45 92

Non-licensed

- None are known

Local Organizations Doing Water Quality Testing

- Action Contre la Faim-Haiti (ACF-Haiti) / Action Against Hunger-Haiti

Drinking Water Quality Testing Country Fact Sheet: Haiti

Local Organizations Providing Training for Water Quality Testing

- None are known

Local Suppliers

Hardware Equipment

- None are known

Consumable Items

- None are known

Membrane Filtration Culture Media Used in the Country

- m-ColiBlue24® (manufactured by Hach)
- Membrane lauryl sulphate broth (MLSB) (various manufacturers)

Tips for Working in Haiti

- The most common way to get water quality testing equipment in Haiti is to import them from the Dominican Republic or United States.
- Most of the the water quality testing laboratories in Haiti provide the following tests:
 - Conductivity
 - Turbidity
 - *E. Coli*
 - Total coliform
 - Salmonella
 - Bacteriological analysis
 - Temperature

CAWST (Centre for Affordable Water and Sanitation Technology)
Calgary, Alberta, Canada
Website: www.cawst.org Email: resources@cawst.org
Wellness through Water.... Empowering People Globally
Last Update: October 2013

This document is open content. You are free to:



- Share – to copy, distribute and transmit this document
- Remix – to adapt this document



Under the following conditions:

- Attribution. You must give credit to CAWST as the original source of the document. Please include our website: www.cawst.org

CAWST does not assume any responsibility for and makes no warranty with respect to the quality of the laboratory services, equipment or consummable products listed in this document.



Drinking Water Quality Testing Country Fact Sheet: Lao PDR

Country Drinking Water Quality Standards

Drinking Water Quality Parameter	National Standard
Microbiological (Thermotolerant coliforms)	0 CFU/100 mL (applies to distributed and non-distributed water systems, emergencies, and storage containers)
Microbiological (Total coliforms)	Distributed water systems: 3-5 CFU/100 mL Non distributed water systems: 5-10 CFU/100 mL Emergencies: 0 CFU/100 mL Storage containers: < 2.2 CFU/100 mL
Turbidity	< 10 NTU
Nitrate	50 mg/L
Arsenic	0.05 mg/L
Fluoride	1.5 mg/L
Antimony	0.005 mg/L
Mercury	0.001 mg/L
Selenium	0.01 mg/L
Total Dissolved Solids	500-600 mg/L

Note: Country standards are under review at the moment.

Laboratories

Licensed

- **Nam Saat Central**
Vientiane Capital (with permission from the Ministry of Health)
- **Nam Papa**
Vientiane Capital
- **Mekong River Commission**
Vientiane Capital
- **Centre for Food and Medical Analysis (Ministry of Health)**
Vientiane Capital

Unlicensed

- None are known

Drinking Water Quality Testing Country Fact Sheet: Lao PDR

Local Organizations Doing Water Quality Testing

- Nam Saat Provinces – Some provinces have small laboratories, but others have received portable test kits from past projects in the areas. The provincial staff may not have the knowledge to perform water quality testing, but you may be able to find and use portable test kits from the following contacts.

Contact person	Telephone	Province	Type of Testing
Vilakhon	n/a	Bokeo	Unknown
Kongkeo	54765810	Luangnamtha	Unknown
Ms. Daovone	59799800	Oudomxai	Unknown
Somdeth	56784392	Xaiyabouly	Unknown
Phaiboun	55771361	Luang Prabang	Lab, complete analysis
Ms. Soukphaivan	97443132	Huaphan	Portable test kit
Bounlenth	56468569	Xieng Khuang	Unknown
Ms. Souban	55401844	Vientiane Capital	Unknown
Ms. Vannuan	55752003	Bolikhamxai	Unknown
Bounchan	55750104	Khammuan	Unknown
Ms. Viengsavanh	55911586	Savannakhet	Lab, complete analysis
Nixai Phoumilath	55288348	Salavan	Portable test kit
Ms. Khomsavan	97693683	Xekong	Unknown
Khomsavan	29294436	Champasack	Unknown
Phomma	5627220	Attapeu	Portable test kit
Mr. Chanta/ Mr. Phousavanh	55902250	Vientiane Capital / Province	Lab, complete analysis
Khamyeay	55787292	Phongsaly	Unknown
Ms. Khonsavan	22204693	Nam Papa (Vientiane)	Lab, complete analysis

Local Organizations Providing Training for Water Quality Testing

- Most of the drinking water quality testing training provided in Laos are internal from Nam Saat Central to Provinces or from Nam Papa to their staff. When other organizations and individuals require water quality testing, they refer people to Nam Saat Central to perform the analysis.

Drinking Water Quality Testing Country Fact Sheet: Lao PDR

Local Suppliers

Hardware Equipment

- **Europ Continents**
237 Ban Sibounhevang Meuang Chanthaboury
PO Box 5933
Vientiane, Lao PDR
Tel: (+856-21) 218322 or 215051 or 252071
Fax: (+851-21) 215052
Website: www.europcontinents.com
- **Saisavat Pharmacy Import – Export**
- **Sokdee Pharmacy Import – Export**
- **Viengthong Pharmacy Import – Export**
- **Sing Loungrod Company**
Nang Kai Province Branch, Thailand
- **Lao Medical Services**
066 Thadeua Rd, Ban Thaphalanxay,
PO Box 4952
Vientiane, Lao PDR
Tel: +856-21-314944/45
Fax: +856-21-314794
Email: contact@lms.la
Website: www.lms.la

Consumable Items

- Same suppliers as above

Membrane Filtration Culture Media Used in the Country

- Membrane lauryl sulphate broth (MLSB) is imported by Avonchem from the UK (www.avonchem.co.uk). It is also available at the local pharmacies listed above.

Tips for Working in the Country

- It takes between two to three months to deliver water quality testing products from other countries.
- Most of the equipment has been imported from the UK or USA, brought by non-governmental organizations as part of their projects.
- Most products and equipment can be found locally at the pharmacies. If it is not available in Laos, it is better to buy the products in Thailand.
- Importing products from Europe or US might be difficult and expensive due to customs, cost of shipping, and taxes.
- The cheapest option for purchasing equipment is Lao Medical Services. They are the biggest provider of equipment for hospitals.



Drinking Water Quality Testing Country Fact Sheet: Lao PDR

CAWST (Centre for Affordable Water and Sanitation Technology)
Calgary, Alberta, Canada
Website: www.cawst.org Email: resources@caust.org
Wellness through Water.... Empowering People Globally
Last Update: October 2013

This document is open content. You are free to:



- Share – to copy, distribute and transmit this document
- Remix – to adapt this document



Under the following conditions:

- Attribution. You must give credit to CAWST as the original source of the document. Please include our website: www.cawst.org

CAWST does not assume any responsibility for and makes no warranty with respect to the quality of the laboratory services, equipment or consummable products listed in this document.

Drinking Water Quality Testing Country Fact Sheet: Zambia

Country Water Quality Standards

Drinking Water Quality Parameter	National Standard
Microbiological (Thermotolerant [Fecal] Coliforms)	0 CFU/100 mL
Turbidity	10 NTU
Nitrate	10 mg/L
Nitrite	1.0 mg/L
Arsenic	0.05 mg/L
Fluoride	1.5 mg/L
Iron	1.0 mg/L
Manganese	0.1 mg/L

Laboratories

Licensed

- Zambia Bureau of Standards**
 Lechwe House, Freedom Way, South End
 P.O. Box 50259, ZA 15101 Ridgeway
 Lusaka, Zambia
 Cell: +260977750010
 Tel: +260211231385
 Fax: +260211238483
- Environmental Engineering Laboratory**
 University of Zambia
 Great East Road Campus
 P.O. Box 32379
 Lusaka, Zambia
 Tel: +260211290962
 Contact: Joel Kabika
- Kafubu Water and Sewerage Company**
 P.O. Box 71278
 Ndola, Zambia
 Tel: +2602622425
 Fax: +2602622177

Drinking Water Quality Testing Country Fact Sheet: Zambia

- **Alfred Knight**
P.O. Box 20303
Corner Mindola Shaft and Golf Club Rd
Nkana West
Kitwe, Zambia
Tel: +260212226433
Fax: +260212226306
- **Tropical Disease Research Centre**
P.O. Box 71769
Ndola Central Hospital
Ndola, Zambia
Tel: +260212611575
Tel: +260212621412
- **Food and Drug Control Laboratory**
University Teaching Hospital
P.O. Box 30138
Lusaka, Zambia
Tel: +260211252855/+260 (211) 252875
- **Indeni Petroleum Refining**
P.O. Box 71869
Ndola, Zambia
Tel: +260212655325
Fax: +260212655191
- **Ndola Lime Company**
P.O. Box 70057
Ndola, Zambia
Tel: +260212621172
Fax: +260212611260
- **Lusaka Water and Sewerage Company**
P.O.Box 50198
Lusaka, Zambia
Tel: +260211250002
- **Ministry of Mines, Energy and Water Development**
P.O. Box 31969
Lusaka, Zambia
Tel: +260 211 251389
Fax: +260253568



Drinking Water Quality Testing Country Fact Sheet: Zambia

- **Eastern Water and Sewerage Company**
P.O. Box 150464
Chipata, Zambia
Tel: +260216221534
Fax: +260216221403
- **Nkana Water and Sewerage Company**
P.O. Box 20982
Kitwe, Zambia
Tel: +260212222488
Fax: +260212222490
- **Southern Water and Sewerage Company**
P.O. Box 61113
Livingstone, Zambia
Tel: +260213322103
- **Lukanga Water and Sewerage Company**
P.O. Box 81745
Kabwe, Zambia
Tel: +260215222474
Tel: +260215223926
- **Western Water and Sewerage Company**
Mongu, Zambia
Tel: +260217221019
- **North Western Water and Sewerage Company**
Solwezi, Zambia
Tel: +260218821330
- **Chambishi Water and Sewerage Company**
P.O. Box
Chambishi, Zambia
Tel: +260212721977
- **Lukanga Water and Sewerage Company**
Chibombo, Zambia
Tel: +260215274125
- **Mulonga Water and Sewerage Company**
Kabundi Road
Chingola, Zambia
Tel: +260212313681



Drinking Water Quality Testing Country Fact Sheet: Zambia

- **Mopani Copper Mines Analytical Services**

P.O. Box 22000
Kitwe, Zambia
Tel: +260212247011
Fax: +260212244002

- **Konkola Copper Mines Analytical Services**

Chingola, Zambia
Tel: +260212350000
Fax: +260212351357

Unlicensed

- None are known

Local Organizations Doing Water Quality Testing

- **Seeds of Hope International Partnerships**

PO Box 250107
Plot 384 Makoli Road
Ndola, Zambia
Tel: +260212671545
Email: info@sohip.org
Website: <http://sohip.org/solutions/wet-c/water/water-quality-testing/>

Local Organizations Providing Training for Water Quality Testing

- **Seeds of Hope International Partnerships**

PO Box 250107
Plot 384 Makoli Road
Ndola, Zambia
Tel: +260212671545
Email: info@sohip.org
Website: <http://sohip.org/solutions/wet-c/water/water-quality-testing/>

Type of training provided: Introduction to Drinking Water Quality Testing workshops
Audience: Government staff, Water Utility Companies, nongovernmental organizations (NGOs), community based organizations (CBOs), individuals working in the water and sanitation sectors

- **University of Zambia**

Environmental Engineering
Great East Road Campus
P.O. Box 32379
Lusaka, Zambia
Tel: +260-1-290598

Type of training provided: Client Driven Training
Audience: Government staff, Water Utility Companies, NGOs, CBOs, individuals working in the water and sanitation sectors



Drinking Water Quality Testing Country Fact Sheet: Zambia

- **Zambia Bureau of Standards**

Lechwe House, Freedom Way, South End
P.O. Box 50259, ZA 15101 Ridgeway
Lusaka, Zambia
Cell: +260977750010
Tel: +260211231385
Fax: +260211238483

Type of training provided: Client Driven Training
Audience: Government staff, Water Utility Companies, NGOs, CBOs, individuals working in the water and sanitation sectors

Local Organizations Providing other Water Quality Services

- **Seeds of Hope International Partnerships**

PO Box 250107
Plot 384 Makoli Road
Ndola, Zambia
Tel: +260212671545
Email: info@sohip.org
Website: <http://sohip.org/solutions/wet-c/water/water-quality-testing/>

Type of service provided: Project Monitoring and Evaluation, Action Research Projects, Presence and Absence test kit sales
Clients: Government departments, Water Utility Companies, NGOs, CBOs, individuals working in the water and sanitation sectors, borehole drillers, bottled water companies, health care professionals



Drinking Water Quality Testing Country Fact Sheet: Zambia

Local Suppliers

Hardware Equipment

Supplier Name and Equipment Available	Contact Person	Phone Number, Fax, Email	Address
THE TECH GROUP Lab equipment and supplies, agents for Wagtech International, Potalab and Potakit portable water quality test kits (see Wagtech website for product list)	In Lusaka: Rhoda	Tel: +260 1 248021/2 Fax: +260 1 246281 Cell: +260 977 606272 Email: techgroupzambia@gmail.com	Plot 4298, Buyantanshi Road, Heavy Industrial Area, PO Box333021/2 Lusaka, Zambia
FERRONES ENTERPRISES Glassware and various lab equipment	Mr Kunda	Tel: +260 977860136	PO Box 70881 Ndola, Zambia Provident House, 9th Floor, Room 904, Ndola, Zambia
KATKAM Ltd Glassware and various lab equipment		Tel: +260955994452 Fax:+260 2 621242 Email : katkamLtd@yahoo.com	Rooms 303 &304, Buteko House, Buteko Avenue, Ndola, Zambia PO Box 240225, Ndola, Zambia
Lab Galore Ltd Various laboratory equipment and precision instruments	Charles Nyirenda (Director)	Telefax: +260 211 841 003/ fax 0211 430345 Cell: +260 955/975 453 823 Email: labgalore@yahoo.com	Shop No. U5 (upstairs) Westgate Shopping Mall, Freedom Way, Lusaka, Zambia

Drinking Water Quality Testing Country Fact Sheet: Zambia

Local Suppliers

Consumable Items

Supplier Name and Consumable Items Available	Contact Person	Phone Number, Fax, Email	Address
THE TECH GROUP Agents for Wagtech International MLSB, chemical testing reagents, turbidity standards, microbiological consumables (e.g., filter paper, pads)	In Lusaka: Rhoda	Tel: +260 1 248021/2 Fax: +260 1 246281 Cell: +260-977-606272 Email: techgroupzambia@gmail.com	Plot 4298, Buyantanshi Road, Heavy Industrial Area, PO Box333021/2 Lusaka, Zambia
FERRONES ENTERPRISES Chemical reagents, methanol, ethanol, pH buffers, membrane filter paper, pads, Petri dishes	Mr Kunda	Tel: +260977860136	P.O.Box 70881 Ndola, Zambia Provident House, 9th Floor, Room 904, Ndola, Zambia
KATKAM Ltd Laboratory chemical reagents, culture media (m-Endo), methanol, ethanol, phosphate buffer, pH buffers, Millipore products		Tel: +260955994452 Fax:+260 2 621242 Email: katkamLtd@yahoo.com	Rooms 303 &304, Buteko House, Buteko Avenue Ndola, Zambia PO Box 240225, Ndola, Zambia
Lab Galore Ltd Diagnostic reagents and chemicals, various culture media, m-Endo media, methanol and ethanol	Charles Nyirenda (Director)	Telefax: +260 211 841 003/ fax 0211 430345 Cell: +260 955/975 453 823 Email: labgalore@yahoo.com	Shop No. U5 (upstairs) Westgate Shopping Mall, Freedom Way, Lusaka, Zambia

Drinking Water Quality Testing Country Fact Sheet: Zambia

Membrane Filtration Culture Media Used in the Country

- Membrane lauryl sulphate broth (MLSB)
- m-Endo

Tips for Working in the Country

- When carrying drinking water quality testing equipment out of the country you must fill out export forms (Customs General Registration Certificates) available at the customs office. A customs officer will come and verify the items on the forms and sign off. An agent can be used if there are numerous items or a complex list. There may be fees attached. See the following page for an example Customs Form.
- Purchasing and importing equipment from out of country is often less expensive, but there are associated customs charges (depends on equipment). Not for profits and NGOs are often exempt, so this may be a viable option.
- Get price comparisons as there are sometimes large price differences between suppliers.
- Give plenty of lead time when ordering supplies. It can take a lot of time to receive orders.
- Develop networking relationships with other laboratories. They can be a valuable source of information and resource sharing.

CAWST (Centre for Affordable Water and Sanitation Technology)
Calgary, Alberta, Canada
Website: www.cawst.org Email: resources@cawst.org
Wellness through Water.... Empowering People Globally
Last Update: October 2013

This document is open content. You are free to:



- Share – to copy, distribute and transmit this document
- Remix – to adapt this document



Under the following conditions:

- Attribution. You must give credit to CAWST as the original source of the document. Please include our website: www.cawst.org

CAWST does not assume any responsibility for and makes no warranty with respect to the quality of the laboratory services, equipment or consummable products listed in this document.



Drinking Water Quality Testing Country Fact Sheet: Zambia

Example Customs Form for Zambia



FORM CT 1

ZAMBIA REVENUE AUTHORITY
Customs and Excise Division

CUSTOMS GENERAL REGISTRATION CERTIFICATE

1. Customs Port/Aerodrome: LUSAKA 2. Date: 07.03.2011

3. Name of Exporter: SEEDS OF HOPE INTERNATIONAL PARTNERSHIP

4. Address in Zambia:

(a) Postal: Box 73272 NDOLA

(b) Residential: PLOT # 384 MAKOLI RD, NDOLA

5. PARTICULARS OF GOODS

FULL DESCRIPTION OF GOODS	SERIAL NUMBERS	VALUES FOR CUSTOMS PURPOSES	FOR OFFICIAL USE ONLY
<u>EGG INCUBATOR</u>	<u>9200</u>	<u>K 60=00</u>	

6. I certify that the above mentioned goods are the property of SEEDS OF HOPE INTERNATIONAL PARTNERSHIP and are being taken out of Zambia for the purpose of PROJECT MONITORING AND EVALUATION and are to be returned to Zambia in due course.

Signature: [Signature] Date: 07.03.2011

FOR OFFICIAL USE ONLY

Name of Customs Officer: JOSEPH P.H.KI

Signature: [Signature] Date: 09/03/2011

DATE STAMP

09 MAR 2011

Port Serial No: 04-03-2011
Number / Month / Year